

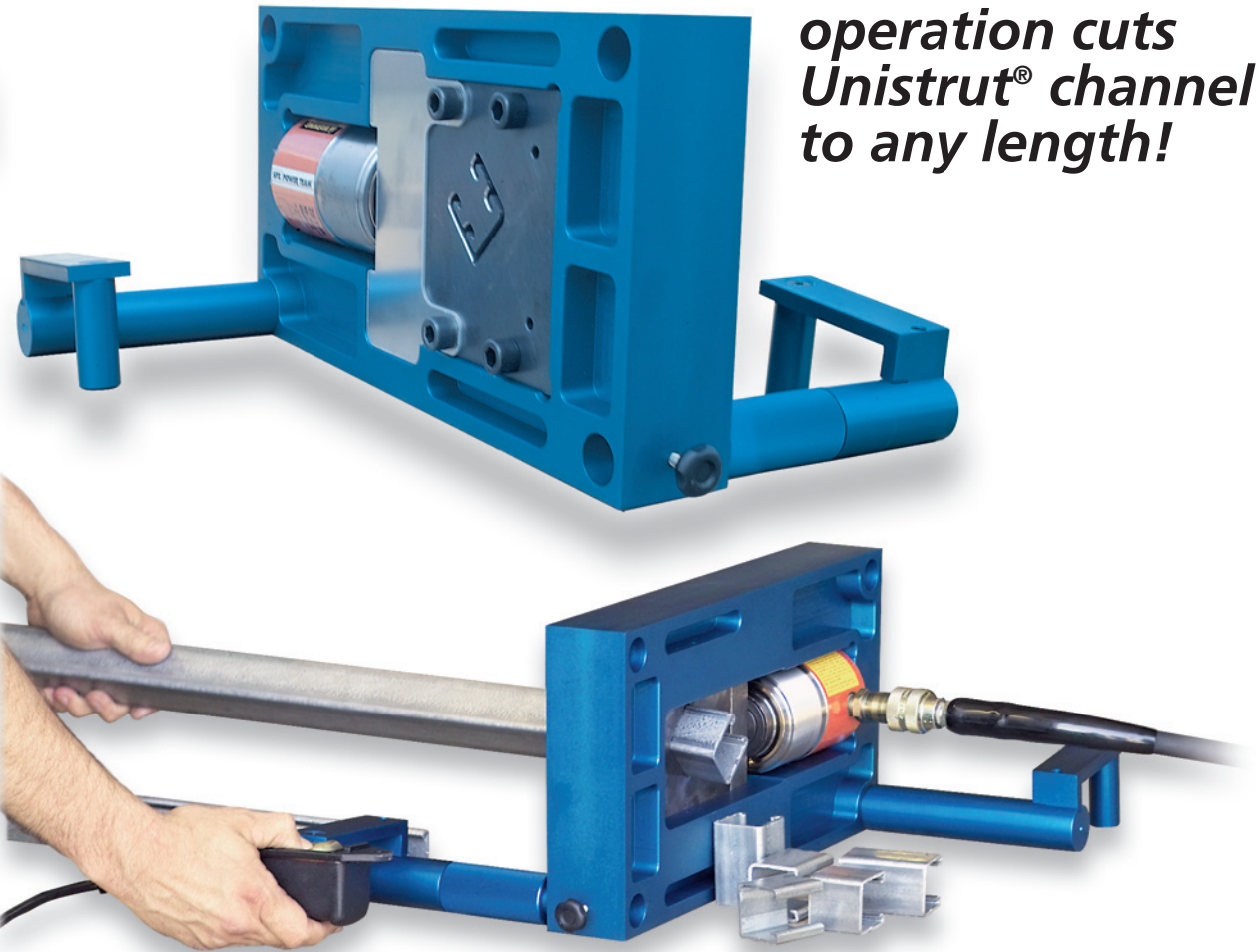

UNISTRUT®

Cut-N-Strut™

Quick & Easy
*Push button
operation cuts
Unistrut® channel
to any length!*



The Original Metal Framing System

PRODUCT
FOCUS

UNISTRUT®

Part no. CNS-CS



PORTABLE Cut-N-Strut tool is equipped with a collapsible handle system that doubles as stabilizing legs. Placing the handles on opposite sides of the tool will provide a stable work area for cutting Unistrut. Once you have set your tool up for cutting, simply attach your hydraulic power source to the Cut-N-Strut universal coupling and you are ready to go. Push the button and the strut is sheared.

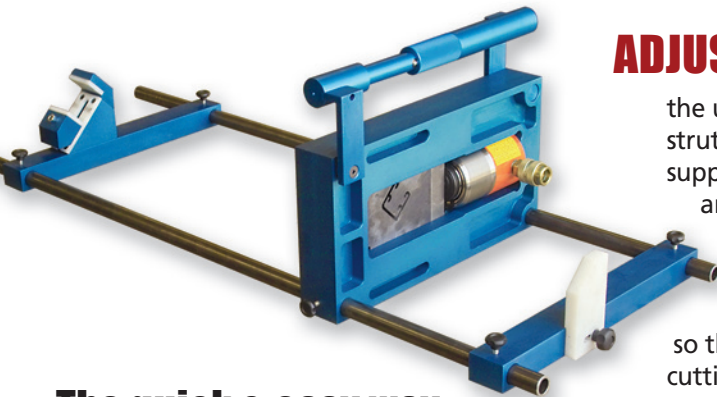
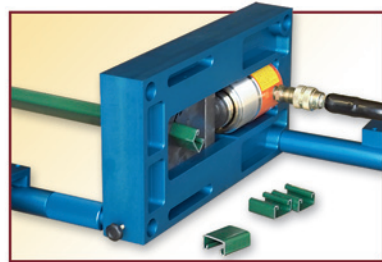
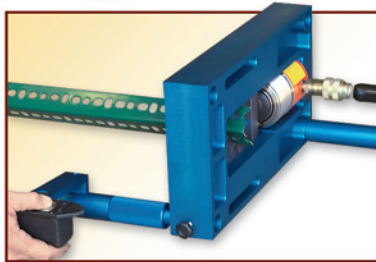
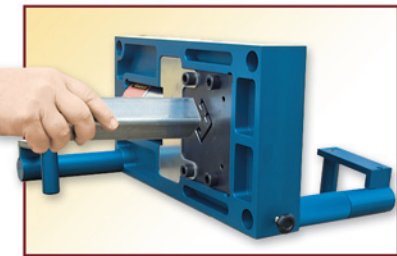

ADJUSTABLE An adjustable material rest and stop are supplied with the unit to simplify cutting longer lengths of strut. A standard 1" o.d. tube or pipe (not supplied) is used to attach the material rest and cutoff stop to the unit.

Just slide the strut through the die until it hits the stop block and then cut it. The stop block is specially designed so that the strut will not jam against it after cutting.

**The quick & easy way
to cut Unistrut Channel
to any length,
anywhere you go!**

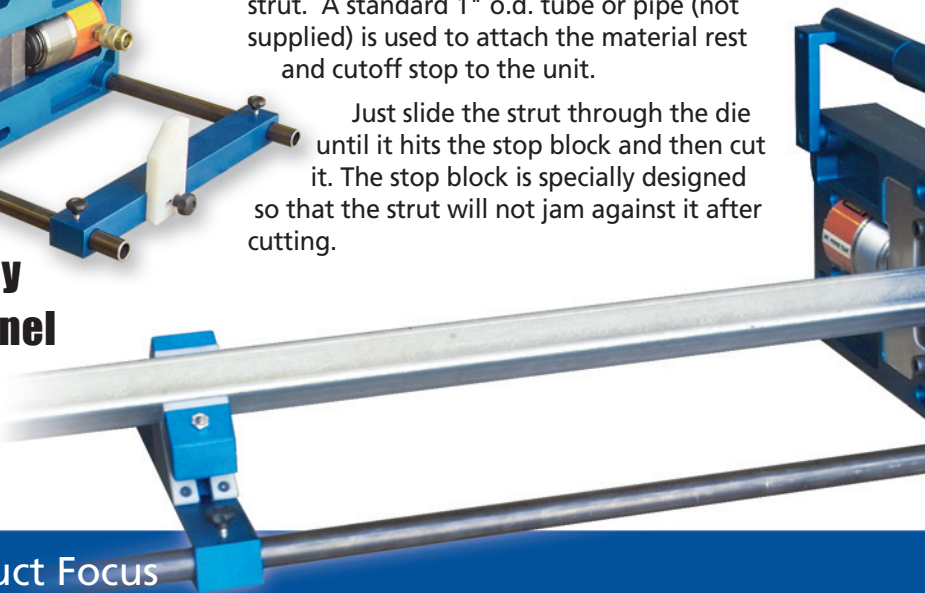

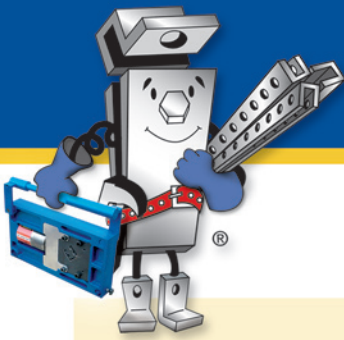

Features & Benefits

- Lightweight 7075-T651 anodized aluminum frame, total unit weight is under 50 lbs.
- 25 Ton hydraulic cylinder for clean, burr-free cuts.
- Compact design for easy transportation to jobsite.
- Collapsible handle provides a portable base.
- Universal hydraulic coupling connects to any 10,000psi hydraulic power source.
 - cut strut with a few pumps of your two-speed porta-power, or
 - the press of a button with your portable electric-hydraulic power unit.
- Die sets available for multiple channel sizes (P1000, P1100, P2000, P4000, P4100) or Prime Angle (PA158).
 - Easy care and maintenance – simple, periodic adjustments and lubricate working surfaces with spray lubricant.

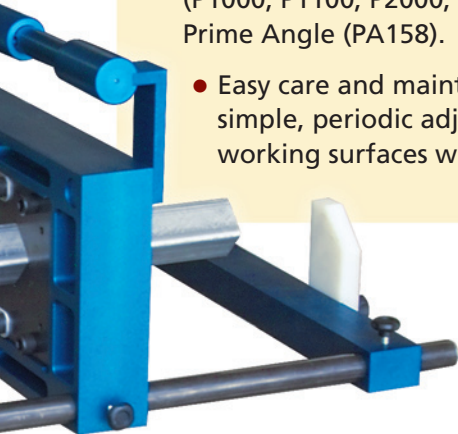

**How much
strut can the
Cut-N-Strut cut?**

CLEAN CUTS

Strut is sheared so the cuts are amazingly clean. No annoying burrs or sharp edges.



This box of several thousand pieces of P1000 were cut with a single set of cutting dies. And, the last cut was as clean as the first.

UNISTRUT®

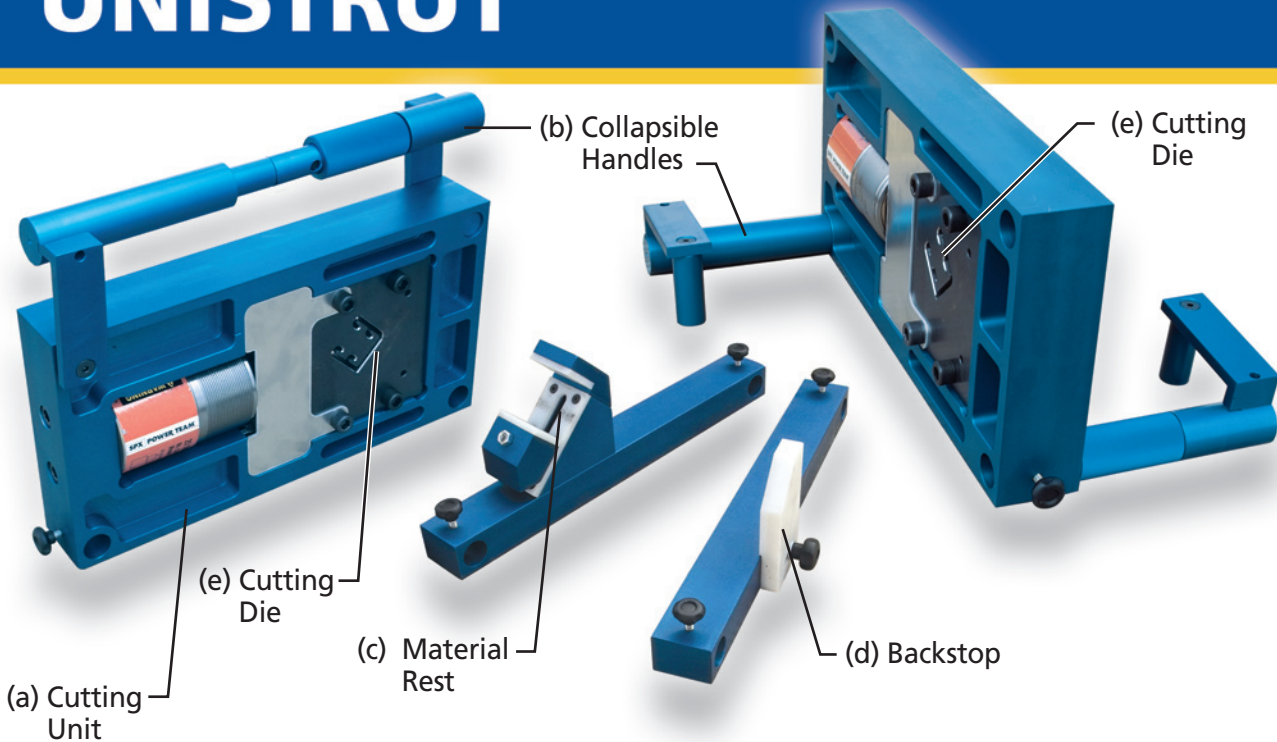

What You'll Get...

(a) CUTTING UNIT - 7075-T651 anodized aluminum frame and compact SPX 25 Ton hydraulic cylinder with universal hydraulic coupling to hook up to any 10,000psi hydraulic power source.

(b) The COLLAPSIBLE HANDLE SYSTEM doubles as a stable base for all your cuts.

(c) CUSTOM MATERIAL REST – assists operator to hold longer pieces of strut.

(d) BACKSTOP – ideal for cutting multiple sections to the same length.

(e) CUTTING DIES – Long life, replaceable dies for Unistrut P1000, P1100, P2000, P4000, P4100 or PA158 Pre-Galvanized or Perma-Green material.

All you need to add is a hydraulic power source, and appropriate length 1" tube for use with the optional material rest and backstop.

4205 Elizabeth
Wayne, MI 48184
Phone: 800-521-7730
Fax: 734-721-4106

www.unistrut.com



Manufactured
in the USA

tyco / Electrical &
Metal Products