

The image shows a close-up of a UNISTRUT seismic bracing system. It consists of several heavy-duty metal beams connected by gusset plates and threaded rods with nuts. The background features a stylized cityscape with blue buildings and a red and white seismic waveform overlay, suggesting the product's application in earthquake-resistant construction.

# UNISTRUT®

## Seismic Bracing

Meets California Building Code (CBC) 2001

As approved by the California Office  
of Statewide Health Planning and  
Development (OSHPD) for Metal  
Framing Bracing Applications.

# Introducing...

## Retrofit seismic fasteners

A family of channel fittings that make retrofitting seismic bracing as easy as...

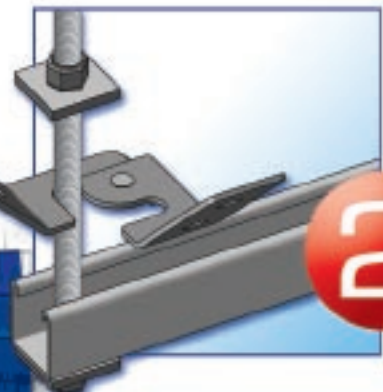
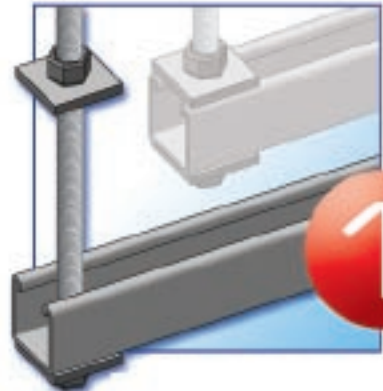
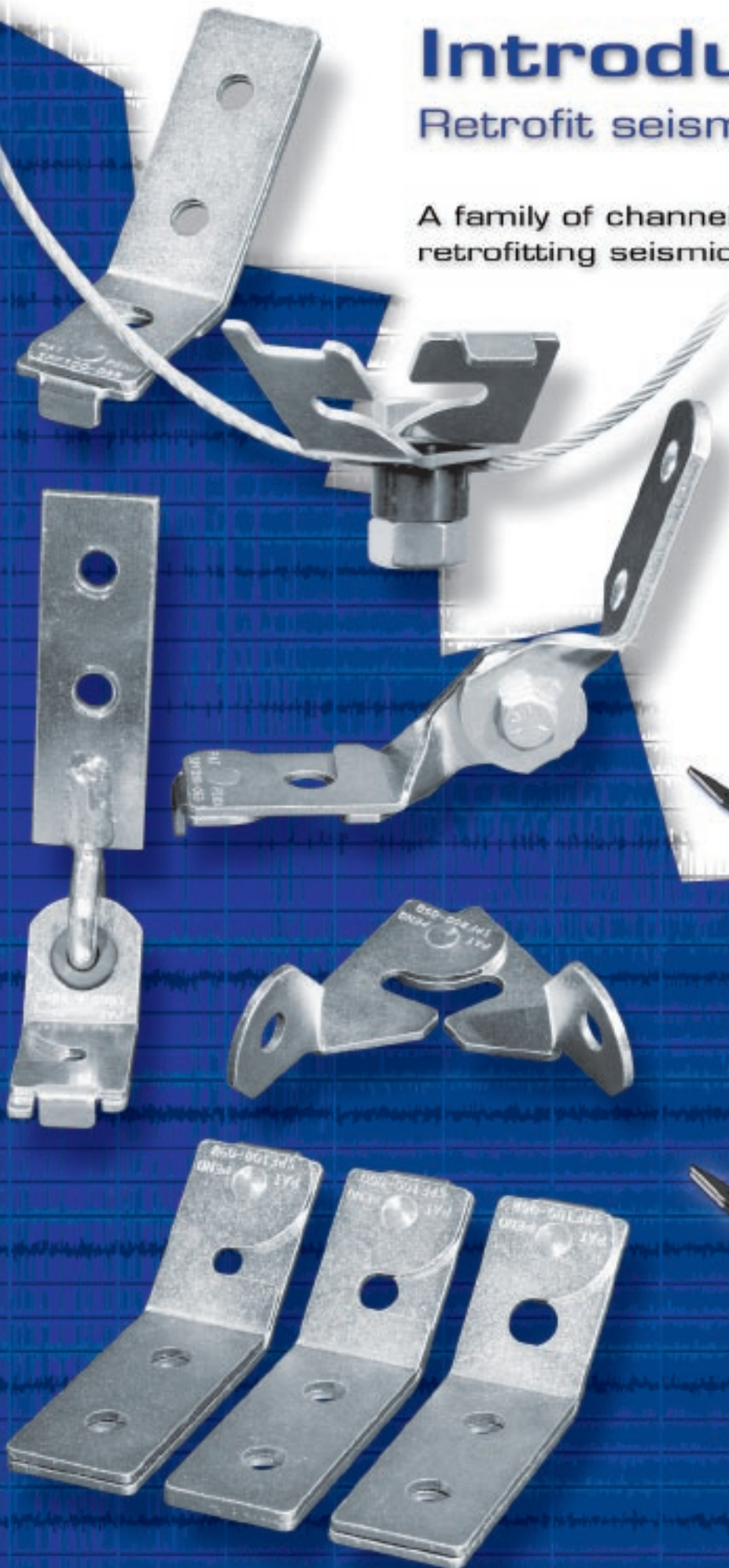

1. Move nut & washer up.
2. Slide fitting around rod.
3. Close fitting & bolt down.

**Introduction.....i**

**General Information ..... 1-1**

**Glossary of Terms ..... 1-3**

**Brace Location Requirements ..... 1-4**

**Design Procedures for Trapeze Hangers ..... 2-1**

**Design Procedures for Single Pipe Hangers ..... 2-6**

**Rigid & Cable Brace Factors ..... 2-7**

**Seismic Table Procedure ..... 2-8**

**Single Pipe Seismic Table ..... 2-9**

**Trapeze Seismic Table ..... 2-10**

**Trapeze Load Data..... 3-1**

**Trapeze Pipe Clamps ..... 3-3**

**Single Pipe Clamps and Bracing ..... 3-5**

**Hanger Rod Stiffeners/Bracing ..... 3-10**

**Channel Styles..... 4-1**

**Channel Load Tables..... 4-4**

**Channel Nuts and Hardware..... 4-5**

**Brace & Cable Design Loads ..... 4-6**

**Channel Fittings ..... 4-7**

**Seismic Pivot Fittings (SPF)..... 4-8**

**Structure Attachments ..... 5-1**

**Typical Attachments..... 5-7**

**Concrete Inserts ..... 5-8**

**Anchor Load Table and Test Procedure..... 6-1**

**Design Examples..... 7-1**

**Reference ..... 8-1**



UNISTRUT Seismic Bracing Systems are designed and constructed to resist virtually all code specified seismic forces in the event of an earthquake; therefore, keeping non-building structural components of hospitals and other essential facilities operational and intact.

Essential facilities are those structures, which are necessary for emergency post-earthquake operations. Such facilities shall include, but not be limited to: Hospitals and other medical facilities having surgery or emergency treatment areas; fire and police stations; municipal government disaster operation and communication centers deemed to be vital in emergencies.

Actual applications may vary and are not limited to support methods shown. However, any changes to the support methods, hardware and designs depicted in these guidelines should only be made in accordance with standard engineering practices by a qualified registered engineer and shall be approved by California Office of Statewide Health Planning and Development (OSHPD) or governing agency.

**UNISTRUT bracing systems designed per the catalog requirements do not guarantee adequacy of existing structures to withstand the loads induced by the seismic attachments.** It is the responsibility of the project engineer to verify that the structure is capable of supporting any and all items constructed using these guidelines. It is the responsibility of the project engineer and the installer to determine the adequacy of placement and installation in regards to these guidelines including compliance with all applicable codes.

Seismic bracing shall not limit the expansion and contraction of systems; the engineer of record shall ascertain that consideration is given to the individual dynamic and thermal properties of these systems and the building structure. Proper seismic & thermal joints should be provided as directed by the project engineer. The details and schedules presented do not include the weights from branch lines. All fire sprinkler branch line bracing shall comply with the requirements of the current edition of the NFPA-13. The project engineer must verify the additional load from branch lines are within the allowable capacity of the bracing details.

Where possible, pipes and conduit and their connections shall be constructed of ductile materials [copper, ductile iron, steel or aluminum and brazed or welded connection]. Pipes and their connections, constructed of other material, e.g. cast iron and no-hub pipe, shall have the brace spacing reduced to one-half of the spacing for ductile pipe.

Pipes, ducts and conduit supported by a trapeze where none of those elements would individually be braced need not be braced if connections to the pipe/conduit/ductwork and directional changes do not restrict the movement of the trapeze. If this flexibility is not provided, bracing will be required when the aggregate weight of the pipes and conduits exceed 10 lb/ft.

<p style="text-align: center;"><b>A P P R O V E D</b>  <b>Fixed Equipment Anchorage</b>          Office of Statewide Health Planning and Development</p> <p style="text-align: center;"><b>OPA-0120 Apr 25, 2003</b></p> <p style="text-align: center;">**** Valid for 3 Years Maximum ****</p>  <p style="text-align: center;">Bill Staehlin (916) 324-9106</p>	 <p style="text-align: right;"><b>UNISTRUT®</b>          35660 Clinton Street          Wayne, Michigan 48184          PH: (800) 521-7730          FAX: (734) 721-4106</p> <p>JOSEPH L. LA BRIE          Structural Engineer          No. SE 3566          55 E. Walnut St. Suite 277          Arcadia, CA 91006</p> 
<p>DATE: <b>04/25/2003</b></p>	<p>PAGE <b>i</b></p>

1. These guidelines are intended to provide information for the seismic restraint of nonstructural components in buildings based on the State of California Code of Regulations (CCR), Title 24. Material contained in this publication can be referenced in the 2001 California Building Code (CBC) based on the 1997 Uniform Building Code (UBC). Nonstructural components may include hospital piping, electrical conduit, cable trays, and air handling ducts. Anyone making use of the data does so at his own risk and assumes any and all liability resulting from such use. **UNISTRUT** disclaims any and all express or implied warranties of fitness for any general or particular application.
2. Seismic horizontal force factor:

$$F_H = \frac{a_p C_a I_p}{R_p} \left( 1 + 3 \frac{h_x}{h_r} \right) W_p \quad \text{Eqn. 2-1}$$

$$F_H = (C_s) W_p \quad \text{Eqn. 2-2}$$

$$F_H \text{ Limited by } : 0.7 C_a I_p W_p \leq F_H \leq 4 C_a I_p W_p \quad \text{Eqn. 2-3}$$



Factoring from Strength Design ( $F_H$ ) to Working Stress ( $F_h$ ) is necessary for Seismic Force to be used in this catalog. Use the following formula:  $F_h = F_H/1.4$ .

The following Seismic Design Coefficient Graph is only applicable when all of the project's seismic coefficients/factors (e.g.  $a_p$ ,  $C_a$ , etc.) are the same as those stated below. Otherwise use Eqn. 2-1 and 2-3 and reference the 2001 CBC.

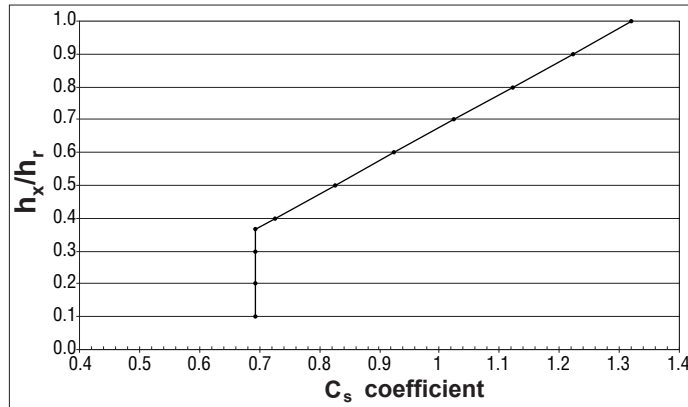
- $a_p$  = 1.0 *Component Amplification Factor*
- $C_a$  = 0.66 *Seismic Coefficient*
- $I_p$  = 1.50 *Seismic Importance Factor*
- $R_p$  = 3.0 *Component Response Modification Factor*
- $h_x$  = equipment attachment elevation with respect to grade
- $h_r$  = structure roof elevation with respect to grade
- $C_s$  = Seismic Design Coefficient (Graph 1 Below) =  $F_H/W_p$  (limits:  $0.693 \leq C_s \leq 3.96$ )

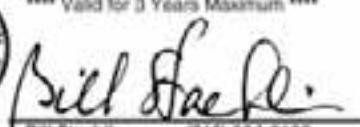

Graph 1: SEISMIC DESIGN COEFFICIENT

<p><b>APPROVED</b>  <b>Fixed Equipment Anchorage</b>                  Office of Statewide Health Planning and Development</p> <p><b>OPA-0120 Apr 25, 2003</b></p> <p>**** Valid for 3 Years Maximum ****</p>  Bill Staehlin (916) 324-9106	<p style="text-align: right;"><b>UNISTRUT®</b></p> <p style="text-align: right;">35660 Clinton Street                  Wayne, Michigan 48184                  PH: (800) 521-7730                  FAX: (734) 721-4106</p> <p style="text-align: center;"></p> <p>JOSEPH L. LA BRIE                  Structural Engineer                  No. SE 3566                  55 E. Walnut St. Suite 277                  Arcadia, CA 91006</p> 				
	<table border="1" style="width: 100%; border-collapse: collapse;"> <tr> <td style="width: 80%;">DATE:</td> <td style="text-align: center;">04/25/2003</td> </tr> <tr> <td style="width: 80%;">PAGE</td> <td style="text-align: center;">1-1</td> </tr> </table>	DATE:	04/25/2003	PAGE	1-1
DATE:	04/25/2003				
PAGE	1-1				



3. When supporting pressure piping, spacing of seismic bracing should not exceed two (2) times the vertical support spacing. Stress in the pipes that are comparable to those required by ASME B31.1 will be maintained.
4. The CCR, Part 2, Title 24, Section 16 states the following:  
Where possible, pipes, conduit, and their connections shall be constructed of ductile materials (copper, ductile iron, steel or aluminum and brazed or welded connections). Pipes, conduits, and their connections, constructed of nonductile materials (e.g., cast iron, no-hub pipe and plastic), shall have the brace spacing reduced to one-half of the spacing allowed for ductile pipe.

Seismic restraints may be omitted from the following installations:

- a. Fuel piping less than one (1) inch inside diameter.
- b. All other piping less than 2.5 inches diameter, except medical gas including vacuum piping, or
- c. All piping suspended by individual hangers twelve (12) inches or less in length from the top of pipe to the bottom of the structural support for the hanger, or
- d. All electrical conduit less than 2.5 inches trade size.
- e. All rectangular air handling ducts less than six (6) square feet in cross-sectional area, or
- f. All round air-handling ducts less than 28 inches in diameter, or
- g. All ducts suspended by hangers 12 inches or less in length from the top of the duct to the bottom of the structural support for the hanger, where the hangers are detailed to avoid bending of the hangers and their connection.

Where lateral restraints are omitted, the piping, ducts or conduit shall be installed such that lateral motion of the piping or duct will not cause damaging impact with other systems of structural members, or loss of vertical support.

5. **UNISTRUT** nuts and bolts mounted to UNISTRUT channels shall be tightened to the following minimum torques:

Bolt Diameter (in)	Bolt Torque (ft-lbs)	Bolt Diameter (in)	Bolt Torque (ft-lbs)
1/4	6	1/2	50
5/16	11	5/8	100
3/8	19	3/4	125

6. The charts and information presented on the following pages are intended as a guide only. Prior to installation, the user and/or engineer of record shall determine structural adequacy of supports and the supporting structure and shall also determine compliance with applicable codes.

**A copy of this Seismic Bracing catalog showing the proper Seismic Brace tables and Brace Location Requirements (Page C3) along with the UNISTRUT Engineering catalog shall be on the jobsite prior to starting the installation of the seismic bracing system. The Seismic Tables defined in Pages 2-8 & 2-9 are for a seismic factor of 1.0g and can be used to determine brace location, sizes, and anchorage of pipe/duct/conduit and trapeze supports. The development of a new seismic table is required for seismic factors other than 1.0g and must be reviewed by OSHPD prior to seismic bracing. For OSHPD, these documents can be considered a change order in accordance with Part1, Title 24, CBC.**

	<p><b>UNISTRUT®</b> 35660 Clinton Street Wayne, Michigan 48184 PH: (800) 521-7730 FAX: (734) 721-4106</p> <p>JOSEPH L. LA BRIE Structural Engineer No. SE 3566 55 E. Walnut St. Suite 277 Arcadia, CA 91006</p>
<p>DATE: <b>04/25/2003</b></p>	<p>PAGE <b>1-2</b></p>

**Grade** – Ground level of building; referred to as 0 ft elevation.

**Lateral Brace** – A generic term used to describe a brace that resist lateral forces in the longitudinal or transverse direction;

**Lateral Force** – Force acting on a component or element that is positioned across, perpendicular, or at a 90° angle to its vertical, in the horizontal direction.

**Longitudinal**– Direction along the horizontal axis of a component or element’s run.

**Shallow Anchors** – Anchors with an embedded length to diameter ratio of less than 8.

**SPF (Seismic Pivot Fitting)** – A retro-fittable brace fitting used with strut or wire. Series SPF fittings are a trademark of Lord & Sons, Inc.

**Run** – Direction of pipe layout, along the axis of the pipe.



**Strength Design** – For load and resistance factor design; ultimate load (design for most critical effects of loads)

**Sway Brace** – A mechanical device used for resisting lateral forces.

**Transverse**– Direction perpendicular to the horizontal of a component or element’s run.

**Trapeze** – Part of an assembly used to help resist seismic forces.

**Working Stress** – Allowable load used for design; factors down strength design loads, providing a safety factor. Generally, strength design forces/1.4.

<p style="text-align: center;"><b>A P P R O V E D</b>  <b>Fixed Equipment Anchorage</b>                  Office of Statewide Health Planning and Development</p> <p style="text-align: center;"><b>OPA-0120 Apr 25, 2003</b></p> <p style="text-align: center;">**** Valid for 3 Years Maximum ****</p>  <p style="text-align: center;">Bill Staehlin (916) 324-9106</p>	 <p style="text-align: right;"><b>UNISTRUT®</b>                  35660 Clinton Street                  Wayne, Michigan 48184                  PH: (800) 521-7730                  FAX: (734) 721-4106</p>  <p>JOSEPH L. LA BRIE                  Structural Engineer                  No. SE 3566                  55 E. Walnut St. Suite 277                  Arcadia, CA 91006</p>
<p>DATE: <b>04/25/2003</b></p>	<p>PAGE  <b>1-3</b></p>



**NOTE:**

1. THIS BRACING DETAIL APPLIES ONLY FOR COLD WATER PIPE AND GAS PIPE WHERE MOVEMENT OF THE PIPE DUE TO TEMPERATURE DIFFERENTIAL IS NEGLIBLE.
2. IT IS THE RESPONSIBILITY OF THE USER OF THIS GUIDELINE TO ASCERTAIN THAT AN ADEQUATE BRACING AND ANCHORAGE DEVICE BE DESIGNED FOR PIPE WHENEVER THE MOVEMENT DUE TO THERMAL DIFERENTIAL AND SEISMIC JOINT OF BUILDING EXISTS.
3. TRANSVERSE BRACES FOR ONE RUN CAN BE USED AS LONGITUDINAL BRACES FOR AN ADJACENT RUN WHERE THE RUN OFFSET IS LESS THAN OR EQUAL TO 24"
4. TRANSVERSE BRACES FOR ONE RUN CAN BE USED AS TRANSVERSE BRACES FOR AN ADJACENT RUN WHERE THE RUN OFFSET IS LESS THAN OR EQUAL TO 24"
5. VERTICAL RUNS MUST HAVE TRANSVERSE BRACING IN EACH DIRECTION AT BOTH ENDS.
6. TRANSVERSE BRACE SPACING SHALL IN NO CASE EXCEED THE MAXIMUM CALCULATED DISTANCE OF 40ft. **(QUALIFIED CALCULATIONS REQUIRED)**  
  
LONGITUDINAL BRACE SPACING IS TWICE TRANSVERSE SPACING BUT IN NO CASE SHALL THE MAXIMUM CALCULATED DISTANCE EXCEED 80ft. **(QUALIFIED CALCULATIONS REQUIRED)**
7. REFERENCE PG 1-5 TO ADDRESS PIPING/CONDUIT HUNG FROM STRUCTURE ABOVE CONNECTING TO EQUIPMENT MOUNTED ON FLOOR BELOW.

**LEGEND**

- T = TRANSVERSE BRACE
- L = LONGITUDINAL BRACE
- V1 = LESS THAN 24" OFFSET VERTICALLY
- V2 = MORE THAN 24" OFFSET VERTICALLY
- H1 = LESS THAN 24" OFFSET HORIZONTALLY
- H2 = MORE THAN 24" OFFSET HORIZONTALLY

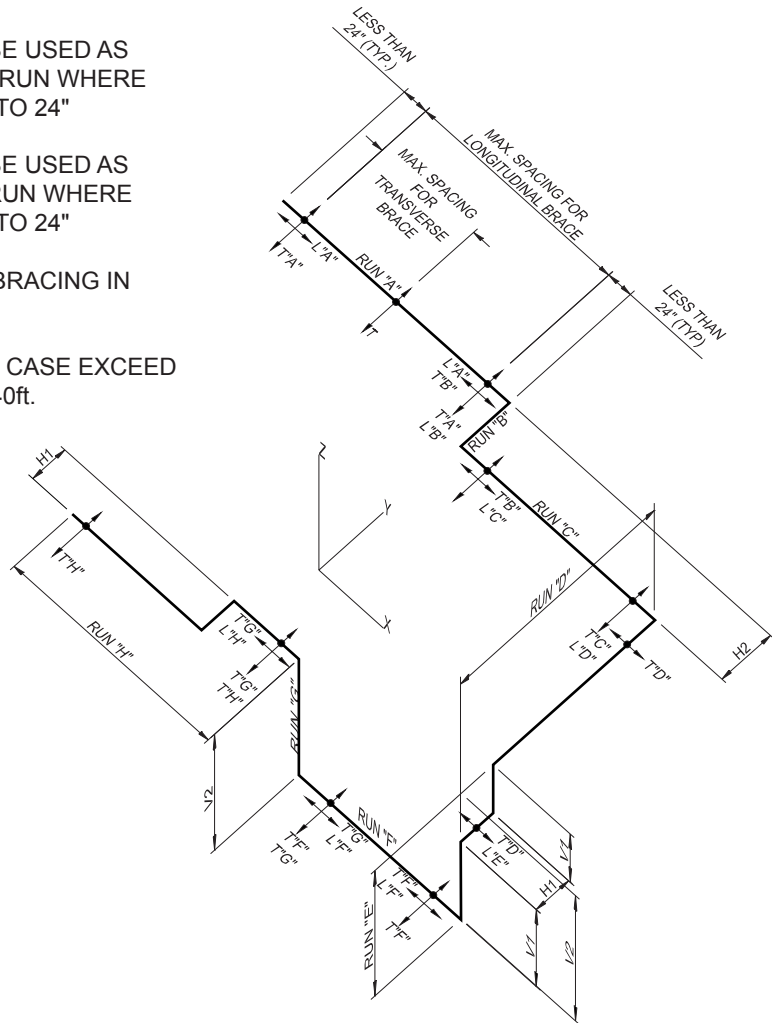

ISOMETRIC DIAGRAM OF TRANSVERESE AND LONGITUDINAL BRACE LOCATION REQUIREMENT

<p><b>APPROVED</b>  <b>Fixed Equipment Anchorage</b>          Office of Statewide Health Planning and Development  <b>OPA-0120 Apr 25, 2003</b>          **** Valid for 3 Years Maximum ****            Bill Staehlin (916) 324-9106</p>	<div style="display: flex; justify-content: space-between;"> <div style="text-align: right;"> <p><b>UNISTRUT®</b>              35660 Clinton Street              Wayne, Michigan 48184              PH: (800) 521-7730              FAX: (734) 721-4106</p> </div> </div> <p>JOSEPH L. LA BRIE              Structural Engineer              No. SE 3566              55 E. Walnut St. Suite 277              Arcadia, CA 91006</p>		
DATE:	04/25/2003	PAGE	1-4

SEE SECTION 5 FOR CONNECTION  
DETAILS TO STRUCTURE ABOVE

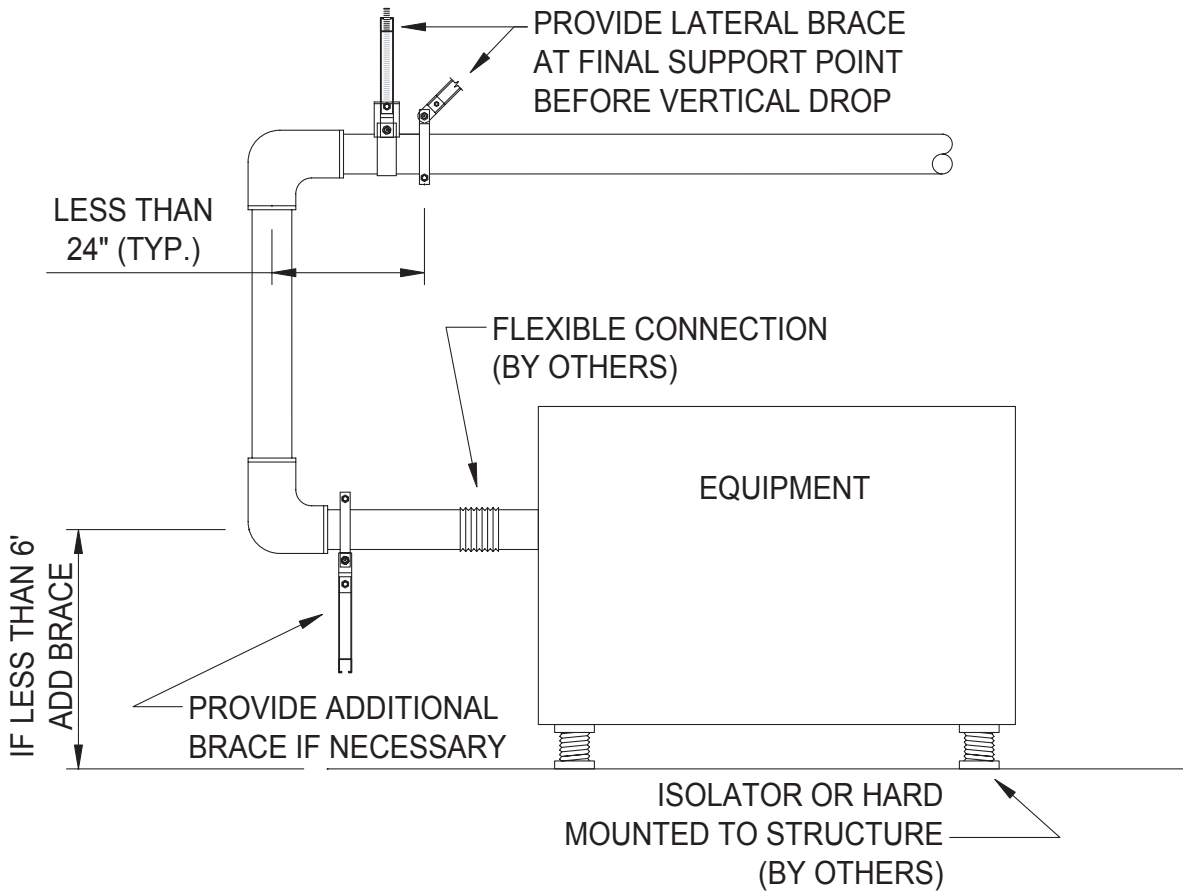

**NOTE:**

DETAIL SHOWS PIPING/CONDUIT HUNG FROM STRUCTURE ABOVE CONNECTING TO EQUIPMENT MOUNTED ON FLOOR TO ADDRESS THE DIFFERENTIAL MOVEMENT BETWEEN STORY TO STORY.

<p><b>APPROVED</b> <b>Fixed Equipment Anchorage</b> Office of Statewide Health Planning and Development</p> <p><b>OPA-0120 Apr 25, 2003</b></p> <p>**** Valid for 3 Years Maximum ****</p> <p><i>Bill Staehlin</i> Bill Staehlin (916) 324-9106</p>	<p><b>UNISTRUT®</b> 35660 Clinton Street Wayne, Michigan 48184 PH: (800) 521-7730 FAX: (734) 721-4106</p> <p><i>Joseph L. LaBrie</i></p> <p>JOSEPH L. LA BRIE Structural Engineer No. SE 3566 55 E. Walnut St. Suite 277 Arcadia, CA 91006</p>
<p>DATE: <b>04/25/2003</b></p>	<p>PAGE <b>1-5</b></p>



1. Determine the support spacing using the smallest pipe diameter (Page 2-3, Pipe Data Table).
2. Calculate the total weight of the pipes plus contents (W) on each trapeze using the following equation: (Page 2-3, Pipe Data Table)

$$W = S \times (p_1 + p_2 + p_3 + \dots + p_n)$$

W = Total weight on trapeze (lbs)  
 $p_n$  = Weight of pipe plus water (lbs/ft)  
 S = Support spacing (ft)

3. Calculate horizontal seismic force ( $F_h$ ). Make necessary checks and conversion as defined in Page 1-1. Page 2-4, Figures 1 & 2 can be used as a reference when solving  $F_h$ .
4. Determine the actual brace force (maximum at 45°). Reference Page 2-7 for brace connection other than 45°.

$$F_{b\text{Actual}} = F_h / \cos 45^\circ = 1.414 F_h$$

5. Select brace to be used, Rigid or Cable.

Select a channel fitting from Page 4-7 to 4-9.  
 Check brace against allowable design load (Page 4-6) and channel slip (Page 4-5).  
 Use the lowest design load as the allowable brace force ( $F_{b\text{Allow}}$ ).

Determine if braces are required depending on type of brace used, Rigid or Cable:

6. Check compression and tension in the rod. When diagonal braces are used to stabilize trapeze hangers, they will cause tension and compression forces to be added to the tension already in the rod (see Page 2-4, Figure 1 or 2, or Page 2-7).
  - a. Select threaded rod that has a tension strength that meets or exceeds the required tension (Page 3-11, Capacity of Threaded Rod Table)

Brace on alternate hangers	$T_{\max} = .5W + s(2W)$	(Page 2-4, Figure 1)
Brace on every hanger	$T_{\max} = .5W + sW$	(Page 2-4, Figure 2)

- b. Check compression in the selected threaded rod. If the rod is subject to compression, it may require stiffener. Determine the percentage of full stress capacity on the rod using the following equation (Page 3-10 & Page 3-11):

$$\frac{\text{Actual Compression Load}}{\text{Allowable Compression Load}}$$

Select clip spacing (L) based on percentage above (Page 3-10, Channel Stiffener Table).

<p><b>APPROVED</b>  <b>Fixed Equipment Anchorage</b>                  Office of Statewide Health Planning and Development  <b>OPA-0120 Apr 25, 2003</b>                  **** Valid for 3 Years Maximum ****  <i>Bill Staehlin</i>                  Bill Staehlin (916) 324-9106</p>	<div style="display: flex; justify-content: space-between;"> <div style="text-align: right;"> <b>UNISTRUT®</b>                      35660 Clinton Street                      Wayne, Michigan 48184                      PH: (800) 521-7730                      FAX: (734) 721-4106                 </div> </div> <p>JOSEPH L. LA BRIE                  Structural Engineer                  No. SE 3566                  55 E. Walnut St. Suite 277                  Arcadia, CA 91006</p> <div style="text-align: right; margin-top: 10px;"> </div>						
	<table border="1" style="width: 100%; border-collapse: collapse;"> <tr> <td style="width: 80%;">DATE:</td> <td style="text-align: center;">04/25/2003</td> <td style="width: 20%;">PAGE</td> </tr> <tr> <td></td> <td></td> <td style="text-align: center;"><b>2-1</b></td> </tr> </table>	DATE:	04/25/2003	PAGE			<b>2-1</b>
DATE:	04/25/2003	PAGE					
		<b>2-1</b>					

- Select pipe clamps (Pages 3-3, 3-4). Either style, P1100 Series or P2558 Series can be used.

Check forces on pipe clamps using the following equations:

Vertical Force = Pipe Wt. per foot x Trapeze spacing

Transverse Force =  $F_h$  x Lateral Brace Spacing

Longitudinal Force =  $F_h$  x Longitudinal Brace Spacing



Revise spacing of braces if necessary (not to exceed allowable design forces).

- Select trapeze member using the total weight on the trapeze and the length of trapeze required to fit the given pipe sizes and quantities (Page 3-1, 3-2, or 4-4).
- Check trapeze member for combined vertical and lateral seismic loads using the following interaction equation: (Revise trapeze spacing or brace if necessary).

$$\frac{\left[ \begin{array}{c} \text{Actual} \\ \text{Vertical Force} \end{array} \right]}{\left[ \begin{array}{c} \text{Lateral} \\ \text{Reduction Factor} \end{array} \right] \times \left[ \begin{array}{c} \text{Allowable} \\ \text{Vertical Force} \end{array} \right]} + \frac{\left[ \begin{array}{c} \text{Actual} \\ \text{Horizontal Force} \end{array} \right]}{\left[ \begin{array}{c} \text{Lateral} \\ \text{Reduction Factor} \end{array} \right] \times \left[ \begin{array}{c} \text{Allowable} \\ \text{Horizontal Force} \end{array} \right]} \leq 1.33$$

- Select concrete anchors if they are used (Page 6-1), check tension and shear interactions as per ICBO reports.

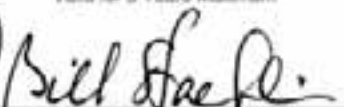
**For shallow anchors:**  $(R_{p(3.0)}/R_{p(1.5)})F_H = 2F_H$

<p style="text-align: center;"><b>A P P R O V E D</b>  <b>Fixed Equipment Anchorage</b>                  Office of Statewide Health Planning and Development</p> <p style="text-align: center;"><b>OPA-0120 Apr 25, 2003</b></p> <p style="text-align: center;">**** Valid for 3 Years Maximum ****</p>  <p style="text-align: center;">Bill Staehlin (916) 324-9106</p>	 <p style="text-align: right;"><b>UNISTRUT®</b>                  35660 Clinton Street                  Wayne, Michigan 48184                  PH: (800) 521-7730                  FAX: (734) 721-4106</p> <p>JOSEPH L. LA BRIE                  Structural Engineer                  No. SE 3566                  55 E. Walnut St. Suite 277                  Arcadia, CA 91006</p> 
DATE: <span style="float: right;">04/25/2003</span>	PAGE <span style="float: right;"><b>2-2</b></span>



### Pipe Data

Data for Schedule 40 Standard Weight Pipe			
Pipe Size (in)	Pipe Section Modulus (in)	Max. Support Spacing Per ASME B31.1*, S (ft)	Weight of Pipe Plus Water, P lbs/ft
1/2	0.041	6**	0.98
3/4	0.071	7	1.36
1	0.133	7	2.05
1 1/2	0.326	9	3.6
2	0.561	10	5.11
2 1/2	1.060	10**	7.87
3	1.720	10**	10.78
4	3.210	10**	16.31
6	8.500	10**	31.51
8	16.800	10**	50.29

\*ASME B31.1 does not list all sizes shown, therefore some sizes have been proportioned between.  
 \*\*Spacing limited by CPC 2001.  
 For gas pipe and copper pipe see CPC 2001 & CBC 2001 for support spacing.

<p style="text-align: center;"><b>A P P R O V E D</b>  <b>Fixed Equipment Anchorage</b>                  Office of Statewide Health Planning and Development</p> <p style="text-align: center;"><b>OPA-0120 Apr 25, 2003</b></p> <p style="text-align: center;">**** Valid for 3 Years Maximum ****</p>  <p style="text-align: center;"><i>Bill Staehlin</i>                  Bill Staehlin (916) 324-9106</p>	 <p style="text-align: right;"><b>UNISTRUT®</b>                  35660 Clinton Street                  Wayne, Michigan 48184                  PH: (800) 521-7730                  FAX: (734) 721-4106</p> <p>JOSEPH L. LA BRIE                  Structural Engineer                  No. SE 3566                  55 E. Walnut St. Suite 277                  Arcadia, CA 91006</p> 
DATE: <b>04/25/2003</b>	PAGE <b>2-3</b>

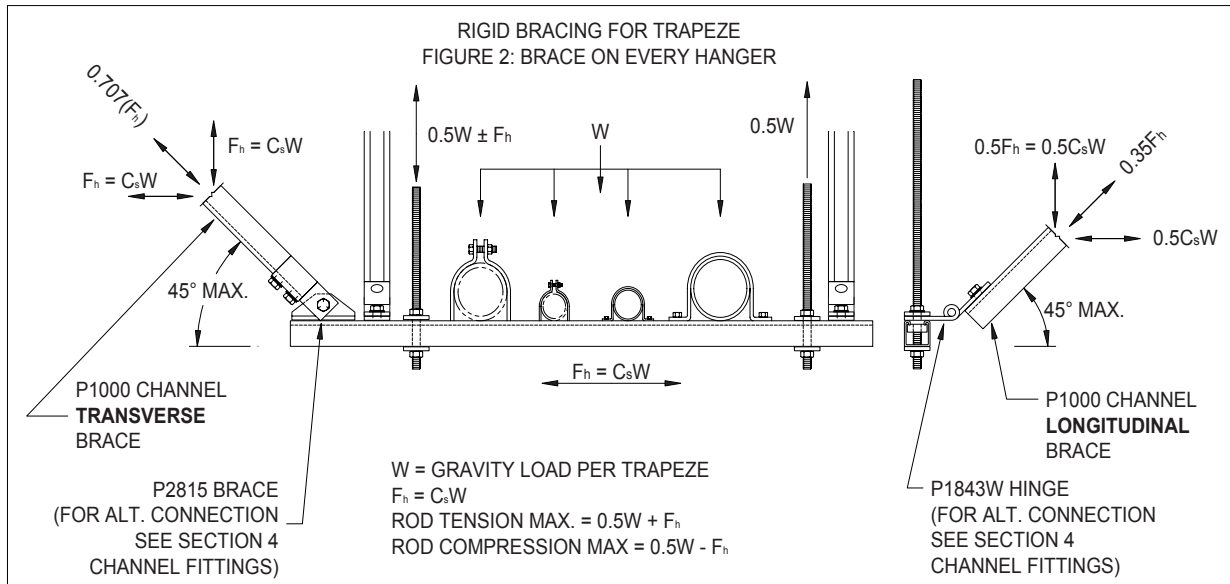
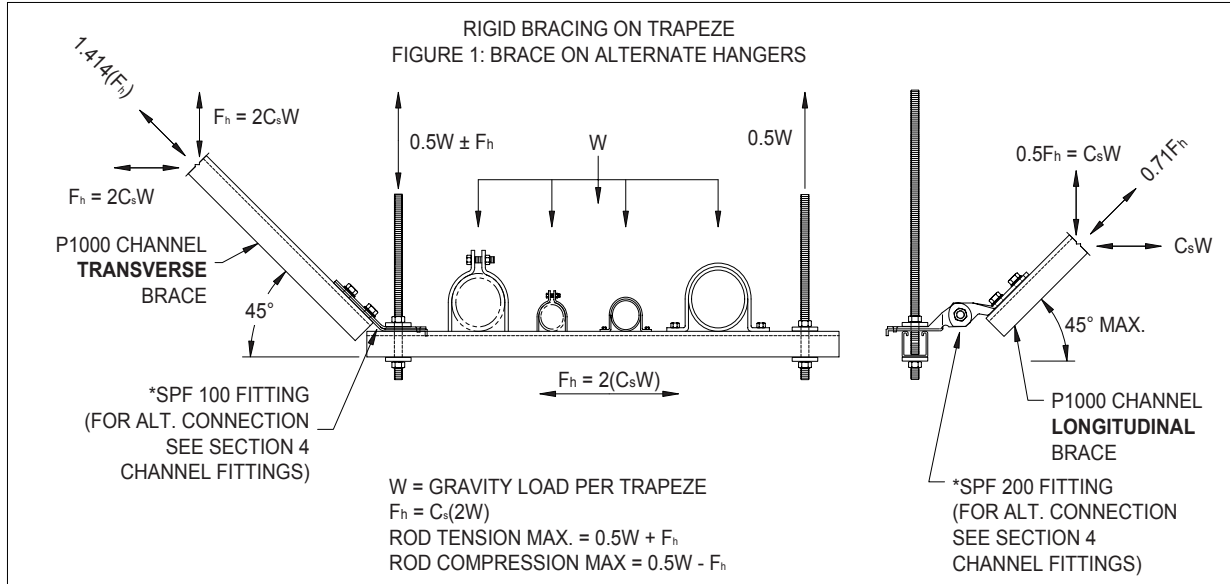

**NOTE:**

- 1) FOR LOAD REACTIONS SHOWN ON THIS PAGE, THE PIPE OR CONDUIT LOADS ON THE TRAPEZE SHOULD BE RELATIVELY UNIFORM AND SYMMETRIC ALONG THE LENGTH OF THE MEMBER.
- 2) SEE PAGE 1-1, SEISMIC DESIGN COEFFICIENT GRAPH, FOR  $C_s$ . USE OF THE SEISMIC DESIGN COEFFICIENT GRAPH IS ONLY APPLICABLE WHEN ALL OF THE PROJECT'S SEISMIC COEFFICIENT/FACTORS ARE THE SAME AS LISTED ON PAGE 1-1, OTHERWISE USE EQN. 2-1, 2-3 AND REFER TO 2001CBC.
- \*3) SPF FITTING IS A TRADEMARK OF LORD & SONS, Inc.



**UNISTRUT®**

35660 Clinton Street  
Wayne, Michigan 48184  
PH: (800) 521-7730  
FAX: (734) 721-4106

JOSEPH L. LA BRIE  
Structural Engineer  
No. SE 3566  
55 E. Walnut St. Suite 277  
Arcadia, CA 91006

DATE:

04/25/2003

PAGE

2-4

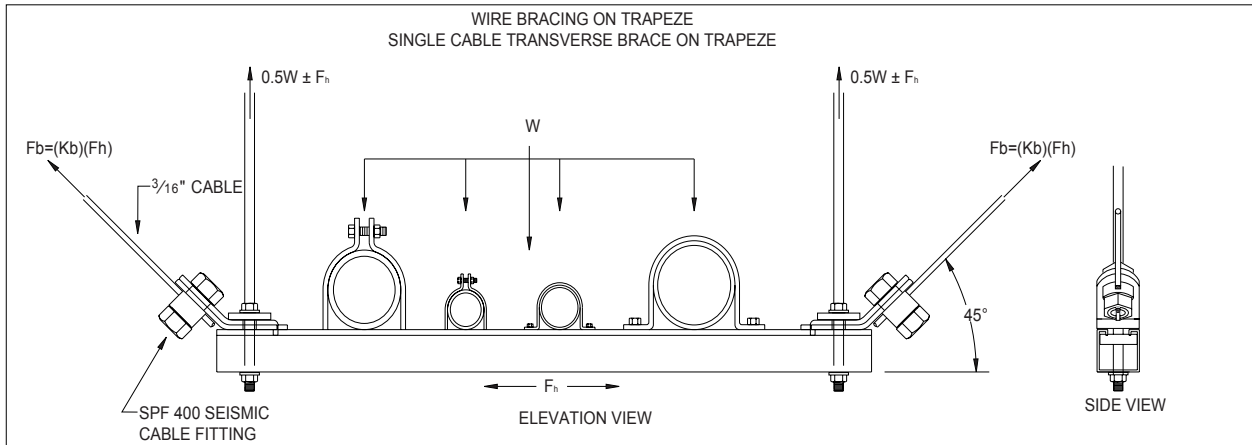
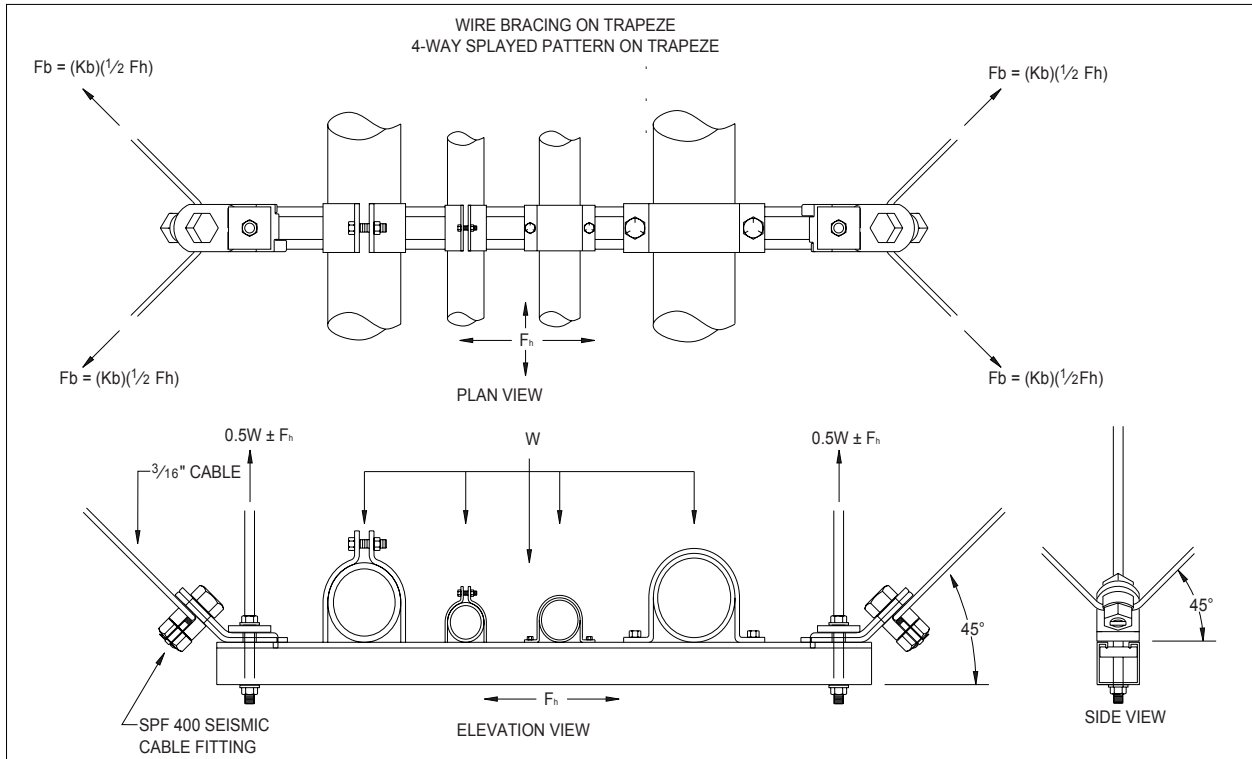

**NOTE:**

- 1) FOR LOAD REACTIONS SHOWN ON THIS PAGE, THE PIPE OR CONDUIT LOADS ON THE TRAPEZE SHOULD BE RELATIVELY UNIFORM AND SYMMETRIC ALONG THE LENGTH OF THE MEMBER.
- 2) REFER TO PAGE 2-7 FOR FORCE FACTORS ON BRACES AND RODS.
- 3) SPF FITTING IS A TRADEMARK OF LORD & SONS, INC.
- 4) ALTERNATE FITTINGS CAN BE USED. SEE SECTION 4 CHANNEL FITTINGS.



**UNISTRUT®**

35660 Clinton Street  
Wayne, Michigan 48184  
PH: (800) 521-7730  
FAX: (734) 721-4106

JOSEPH L. LA BRIE  
Structural Engineer  
No. SE 3566  
55 E. Walnut St. Suite 277  
Arcadia, CA 91006

DATE:

04/25/2003

PAGE

2-5

- Select hanger type (Pages 3-5 through 3-9) given the diameter of the pipe.
- Determine the maximum hanger spacing (Page 2-3, Pipe Data Table). Calculate the total weight of the pipe and contents using the following equation:  
 $W = S \times p$   
 W = Total weight on hanger (lbs)  
 p = Weight of pipe plus water (lbs/ft)  
 S = Support spacing (ft)
- Calculate horizontal seismic force ( $F_H$ ) from the following,  
 $F_H = C_s W$   
 Refer to Page 1-1 and Check if within limits. Convert from strength design  $F_H$  to working stress  $F_h$  for values to be used in this catalog.
- Check brace forces (max. at 45°) at every other hanger and select fittings from Page 4-6. Reference Page 2-7 for brace connections other than 45°.  
 $F_{b \text{ Actual}} = F_h / \cos 45^\circ = 1.414 F_h$
- Select brace to be used, Rigid or Cable.  
 Check brace against allowable design load (Page 4-6) and channel slip (Page 4-5).  
 Select a fitting from Pages 4-7 to 4-9.  
 The lowest allowable design load (Allowable  $F_h$ ) governs.

Determine if longitudinal braces are required using the following equation:

**Brace Spacing = Allowable  $F_b$  / (1.414  $F_h$  x hanger spacing)**

- Check tension of rod (reference Page 2-7):



$T_{max} = W + F_y$   
 $F_y = K_y \cdot F_h$

Check compression:  $\frac{\text{Actual Compression Load}}{\text{Allowable Compression Load}}$

Select clip spacing (L) based on percentage above (Page 3-10, Channel Stiffener Table)

- Verify pipe clamp capacity (use Design Table in Page 3-6)  
 Actual Longitudinal Force =  $F_h \times$  Longitudinal Brace space
- Select concrete anchors if they are used (See Page 6-1), check tension and shear interactions as per ICBO reports.

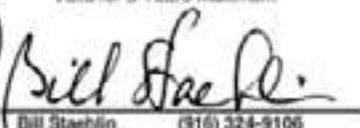
Note: For shallow anchors:  $(R_{p(3.0)} / R_{p(1.5)}) F_H = 2 F_H$

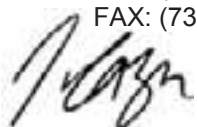
<p style="text-align: center;"><b>A P P R O V E D</b>  <b>Fixed Equipment Anchorage</b>                  Office of Statewide Health Planning and Development</p> <p style="text-align: center;"><b>OPA-0120 Apr 25, 2003</b></p> <p style="text-align: center;">**** Valid for 3 Years Maximum ****</p>  <p style="text-align: center;">Bill Stashin (916) 324-9106</p>	 <p style="text-align: right;"><b>UNISTRUT®</b>                  35660 Clinton Street                  Wayne, Michigan 48184                  PH: (800) 521-7730                  FAX: (734) 721-4106</p> <p>JOSEPH L. LA BRIE                  Structural Engineer                  No. SE 3566                  55 E. Walnut St. Suite 277                  Arcadia, CA 91006</p> 
<p>DATE: <b>04/25/2003</b></p>	<p>PAGE  <b>2-6</b></p>

**SINGLE RIGID BRACE**

ELEVATION VIEW  
TRAPEZE

**TWO OPPOSING CABLE BRACES**

PLAN VIEW

SINGLE PIPE

TRAPEZE

BRACE SLOPE		SLOPE FACTORS		
RISE	RUN	Kb	Kx	Ky
1	1	1.414	1.000	1.000
1	2	1.118	1.000	0.500
1	3	1.054	1.000	0.333
1	4	1.031	1.000	0.250

**BRACE AXIAL FORCE:**  
 $\pm F_b = K_b * F_h$  (Rigid Brace – Tension & Compression)  
 $+F_b = K_b * F_h$  (Cable Brace – Tension only)  
 $K_b =$  Brace Factor  
 $F_h =$  Horizontal Seismic Factor  
 $F_y = K_y * F_h$   
 $F_x = K_x * F_h$

**4-WAY SPLAYED PATTERN**

PLAN VIEW

SINGLE PIPE

TRAPEZE

BRACE SLOPE			SLOPE FACTORS		
X	Y	Z	Kb	Kx	Ky
1	1	1	2.000	1.000	1.000

**BRACE AXIAL FORCE:**  
 $F_b = K_b * \frac{1}{2} F_h = 2.000 * (\frac{1}{2} F_h)$   
 $F_b = F_h$  (Tension only)  
 $K_b =$  Brace Factor  
 $F_h =$  Horizontal Seismic Factor  
 $F_y = K_y * F_h$   
 $F_x = K_x * F_h$

**APPROVED**

**Fixed Equipment Anchorage**

Office of Statewide Health Planning and Development

**OPA-0120 Apr 25, 2003**

\*\*\*\* Valid for 3 Years Maximum \*\*\*\*

*Bill Staehlin*

Bill Staehlin (916) 324-9106

JOSEPH L. LA BRIE  
 Structural Engineer  
 No. SE 3566  
 55 E. Walnut St. Suite 277  
 Arcadia, CA 91006

**UNISTRUT®**

35660 Clinton Street  
 Wayne, Michigan 48184  
 PH: (800) 521-7730  
 FAX: (734) 721-4106

DATE: **04/25/2003**

PAGE  
**2-7**



The following procedures are for the Seismic Tables defined in Pages 2-9 & 2-10 with a Seismic Factor of 1.0g. The Sample Procedure in Pages 2-1 & 2-6 provides a detailed description for determining bracing of Trapeze and Individually supported Water Filled Pipes, when variation of components or the use of seismic factors other than 1.0g is required for design.

**STEPS PROCEDURE FOR USE OF SINGLE PIPE SEISMIC TABLE**

1. Determine size of pipe to be braced.
2. Select type of Pipe Hanger to be used. Reference Page 3-5.
3. Determine transverse and longitudinal brace location requirements. Reference Pages 1-4 & 1-5.
4. From Single Pipe Seismic Table, obtain Maximum Brace Spacing, Minimum Rod Diameter, & Limiting Brace Length.
5. Determine type of structure (concrete, wood, steel) and from the table select Anchorage quantity, size, & embedment (where applies).

**STEPS PROCEDURE FOR USE OF TRAPEZE SEISMIC TABLE**

1. Determine the maximum vertical load distributed uniformly on the trapeze from pipe(s) being braced.
2. Knowing the pipe size(s), select the type and length of Trapeze from the Trapeze Seismic Table.
3. From the table, select Maximum Transverse Brace Space and Minimum Rod Diameter.
4. Determine transverse and longitudinal brace location requirements. Reference Pages 1-4 & 1-5.
5. Determine type of structure (concrete, wood, steel) and from the table select Anchorage quantity, size, & embedment (where applies).

<div style="border: 1px solid black; padding: 10px; text-align: center;"> <p><b>A P P R O V E D</b>  <b>Fixed Equipment Anchorage</b>  <small>Office of Statewide Health Planning and Development</small></p> <p><b>OPA-0120 Apr 25, 2003</b></p> <p><small>**** Valid for 3 Years Maximum ****</small></p>   <small>Bill Staehlin (916) 324-9106</small> </div>	<div style="display: flex; justify-content: space-between;">  <div style="text-align: right;"> <p><b>UNISTRUT®</b>                      35660 Clinton Street                      Wayne, Michigan 48184                      PH: (800) 521-7730                      FAX: (734) 721-4106</p> </div> </div> <div style="margin-top: 10px;"> <p>JOSEPH L. LA BRIE                      Structural Engineer                      No. SE 3566                      55 E. Walnut St. Suite 277                      Arcadia, CA 91006</p>  </div>
<p>DATE: <b>04/25/2003</b></p>	<p>PAGE <b>2-8</b></p>



### SINGLE PIPE SEISMIC TABLE Seismic Factor (not to exceed) = 1.0g

Pipe Diameter (in)	Pipe Hanger Type	Max. Brace Spacing		ANCHORAGE (Reference Section 5 for anchorage details)										
				Min. Rod (in)	Normal Weight Concrete			Light Weight Concrete			Structural Wood Beam		Structural Steel Beam	
		Trans. (ft)	Long. (ft)		Qty. (Min.)	Dia. (in)	Embed. (in)	Qty. (Min.)	Dia. (in)	Embed. (in)	Thru Bolt Qty.	Dia. (in)	A307 Bolt Qty.	Dia. (in)
1/2	J1205	40	80	3/8	1	1/2	4 1/8	1	5/8	5 1/8	1	1/2	1	1/2
3/4	J1207	40	80											
1	J1210	40	80											
1 1/2	J1215	40	58											
2	J1220	40	41											
2 1/2	J1225	26	26	1/2	1	1/2	4 1/8	1	5/8	5 1/8	1	1/2	1	1/2
3	J1230	19	19											
4	J1240	12	12	5/8	1	1/2	4 1/8	1	5/8	5 1/8	1	1/2	1	1/2
5	J1250	9	9											
6	J1260	6	6											
8	J1280	4	4	3/4	1	1/2	4 1/8	1	5/8	5 1/8	1	1/2	1	1/2

**NOTES:**

- System must be engineered for variation of components (ie: size, quantity, spacing) needed to the listed values that are outside the scope of this table.
- Pipe (water filled), see Page 2-3 for pipe properties.
- Pipe Hanger capacity and details, see Pages 3-5 to 3-9.
- Brace location requirements, reference Page 1-4.
- Maximum support rod spacing per ASME B31.1, reference Page 2-3.
- Maximum P1000 allowable brace length is 10 ft. at maximum brace angle of 45°.
- 1/2" bolt(s) and nut(s) required on brace connectors attached to channels in this catalog.  
(refer to Page 4-5 for allowable loads of nut in channel)

<p style="text-align: center;"><b>APPROVED</b> <b>Fixed Equipment Anchorage</b> Office of Statewide Health Planning and Development</p> <p style="text-align: center;"><b>OPA-0120 Apr 25, 2003</b></p> <p style="text-align: center;">**** Valid for 3 Years Maximum ****</p>  <p style="text-align: center;">Bill Staehlin (916) 324-9106</p>	 <p style="text-align: right;"><b>UNISTRUT®</b> 35660 Clinton Street Wayne, Michigan 48184 PH: (800) 521-7730 FAX: (734) 721-4106</p> <p>JOSEPH L. LA BRIE Structural Engineer No. SE 3566 55 E. Walnut St. Suite 277 Arcadia, CA 91006</p> 
<p>DATE: <b>04/25/2003</b></p>	<p>PAGE <b>2-9</b></p>

**TRAPEZE SEISMIC TABLE**

Seismic Factor (not to exceed) = 1.0g

Maximum Vertical Load	Transv. Brace Space (max)	Maximum Trapeze Lengths				Min. Rod Dia.	Anchorage																		
		P1000 Trapeze	PS1001 Trapeze	P5500 Trapeze	P5501 Trapeze		Normal Weight Concrete			Light Weight Concrete			Structural Wood Beam		Structural Steel Beam										
							Qty	Dia.	Embed.	Qty	Dia.	Embed.	Thru Bolt	Dia.	A307 Bolt	Dia.									
(plf)	(ft)	(ft)	(ft)	(ft)	(ft)	(in)	(Min.)	(in)	(in)	(Min.)	(in)	(in)	(Qty)	(in)	(Qty)	(in)									
9	40	5	10	8	10	1/2	1	1/2	4 1/8	1	5/8	5/8	2	1/2	1	1/2									
11		4	9	6																					
15	40	3	7	5	10	5/8											1/2	4 1/8	2	5/8	5/8	2	1/2	1	1/2
17		3	6	4	9																				
18		2	6	4	8																				
22		2	6	4	9																				
24	30	2	5	4	8	1/2											5/8	5 1/8	2	5/8	5/8	2	5/8	1	1/2
28, 29		3	6	4	10																				
32	20	2	6	4	9	5/8											5/8	5 1/8	2	5/8	5/8	2	5/8	1	1/2
33, 34		2	5	4	8																				
37	10	3	8	6	10	1/2											1/2	4 1/8	1	5/8	5/8	2	5/8	1	1/2
40		3	8	5																					
41, 44, 45		3	7	5																					
48, 49, 50		2	6	4																					

- Notes:
1. System must be engineered for variation of components (ie: size, quantity, spacing) needed to the listed values that are outside the scope of this table.
  2. Maximum vertical load (plf) simulates linear load of pipe(s) along pipe axis uniformly distributed on trapeze.
  3. Maximum Longitudinal Brace Space is 2x Transverse Brace Space, not to exceed 80 ft.
  4. Maximum Trapeze Lengths are for Uniform Load Capacities of Trapeze (see Pages 3-1, 3-2, 4-4) braced longitudinally. (When loads are concentrated at or near midspan of trapeze use 1/2 of maximum trapeze length defined in table (min. of 2ft).
  5. For non-braced Trapeze: type, length, & use of smaller components can be acquired, reference Note 1.
  6. Maximum P1000 allowable brace length is 10 ft. for loads listed in table. **(TABLE IS FOR RIGID BRACE ONLY)**
  7. Maximum Hanger Spacing = 10ft.
  8. 1/2" bolt(s) and nut(s) required on brace connectors attached to channels in this catalog.
  9. Minimum 3,000 psi normal weight and light weight concrete slab/deck.

<p style="text-align: center;"><b>A P P R O V E D</b>  <b>Fixed Equipment Anchorage</b>                  Office of Statewide Health Planning and Development</p> <p style="text-align: center;"><b>OPA-0120 Apr 25, 2003</b></p> <p style="text-align: center;">**** Valid for 3 Years Maximum ****</p>  <p style="text-align: center;">Bill Staehlin (916) 324-9106</p>	 <p style="text-align: right;"><b>UNISTRUT®</b>                  35660 Clinton Street                  Wayne, Michigan 48184                  PH: (800) 521-7730                  FAX: (734) 721-4106</p> <p>JOSEPH L. LA BRIE                  Structural Engineer                  No. SE 3566                  55 E. Walnut St. Suite 277                  Arcadia, CA 91006</p> 
DATE: <b>04/25/2003</b>	PAGE <b>2-10</b>

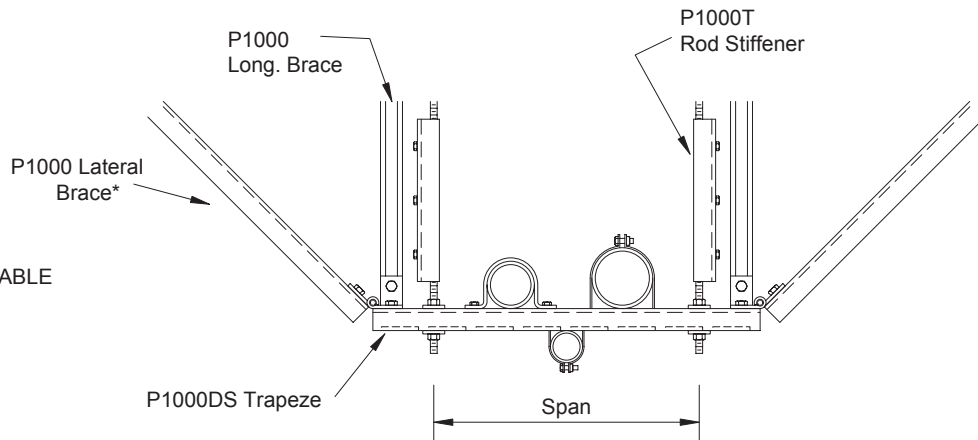
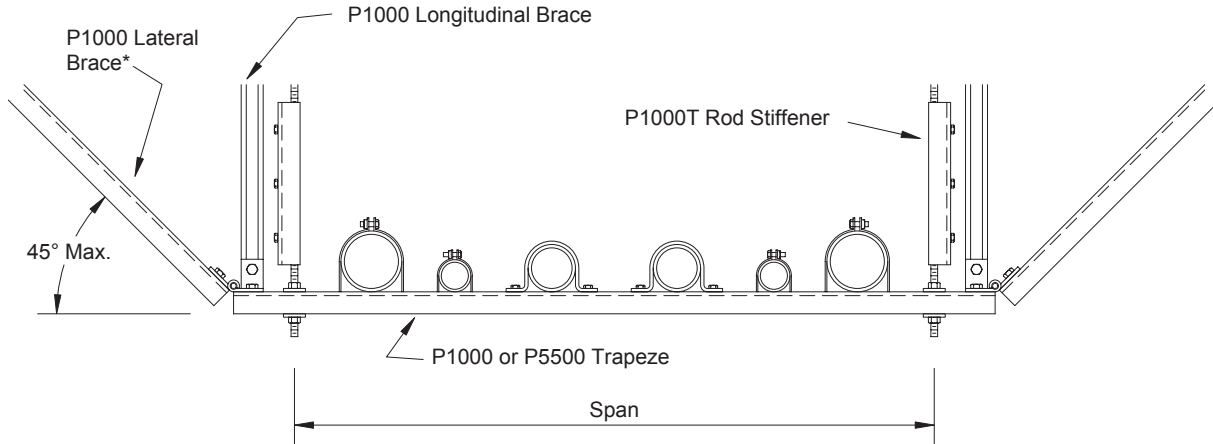

\*FOR ALTERNATE CABLE BRACE SEE PG 2-5

### P1000 Trapeze Load Data

Span		Maximum Uniform Design Load		Concentrated Load @Center of Span	
In	mm	Lbs.	N	Lbs	N
24	610	1,690	7,520	850	2,000
36	914	1,130	5,030	560	2,490
48	1,219	850	3,780	420	1,870
60	1,524	680	3,020	340	1,510
72	1,829	560	2,490	280	1,250
84	2,134	480	2,140	240	1,070
96	2,438	420	1,870	210	930
108	2,743	380	1,690	190	850
120	3,048	340	1,510	170	760

### P5500 Trapeze Load Data

Span		Maximum Uniform Design Load		Concentrated Load @Center of Span	
In	mm	Lbs.	N	Lbs	N
24	610	3,280	14,590	1,620	7,210
36	914	2,190	9,740	1,080	4,800
48	1,219	1,640	7,300	810	3,600
60	1,524	1,310	5,830	656	2,920
72	1,829	1,090	4,850	540	2,400
84	2,134	940	4,180	460	2,050
96	2,438	820	3,650	400	1,780
108	2,743	730	3,250	360	1,600
120	3,048	660	2,940	320	1,420



**UNISTRUT®**

35660 Clinton Street  
Wayne, Michigan 48184  
PH: (800) 521-7730  
FAX: (734) 721-4106

JOSEPH L. LA BRIE  
Structural Engineer  
No. SE 3566  
55 E. Walnut St. Suite 277  
Arcadia, CA 91006

DATE:

04/25/2003

PAGE

3-1

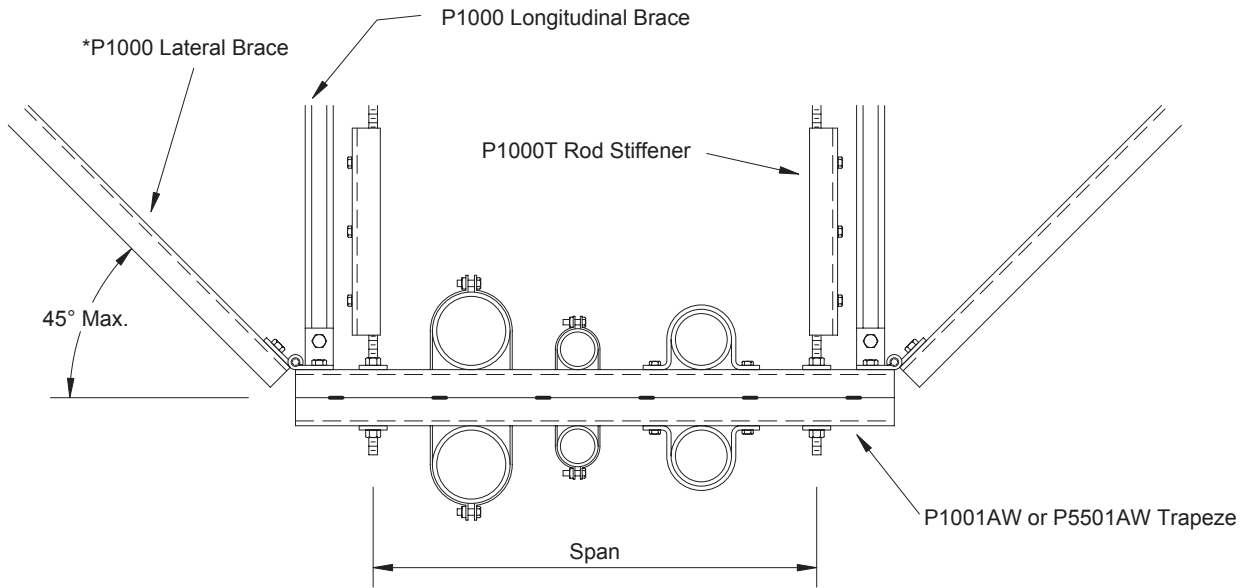

\*FOR ALTERNATE CABLE BRACE SEE PAGE 2-5

**P1001-AW Trapeze Load Data**

Span		Maximum Uniform Design Load		Concentrated Load @Center of Span	
In	mm	Lbs.	N	Lbs	N
48	1,219	2,400	10,680	1,190	5,290
60	1,524	1,920	8,540	950	4,230
72	1,829	1,600	7,120	790	3,510
84	2,134	1,370	6,090	680	3,020
96	2,438	1,200	5,340	590	2,620
108	2,743	1,070	4,760	530	2,360
120	3,048	960	4,270	470	2,090

**P5501-AW Trapeze Load Data**

Span		Maximum Uniform Design Load		Concentrated Load @Center of Span	
In	mm	Lbs.	N	Lbs	N
48	1,219	4,680	20,820	2,390	10,630
60	1,524	3,870	17,210	1,920	8,540
72	1,829	3,220	14,320	1,600	7,120
84	2,134	2,760	12,280	1,360	6,050
96	2,438	2,420	10,760	1,190	5,290
108	2,743	2,150	9,560	1,060	5,160
120	3,048	1,930	8,590	950	4,230



**UNISTRUT®**

35660 Clinton Street  
 Wayne, Michigan 48184  
 PH: (800) 521-7730  
 FAX: (734) 721-4106

JOSEPH L. LA BRIE  
 Structural Engineer  
 No. SE 3566  
 55 E. Walnut St. Suite 277  
 Arcadia, CA 91006

DATE:

04/25/2003

PAGE

**3-2**

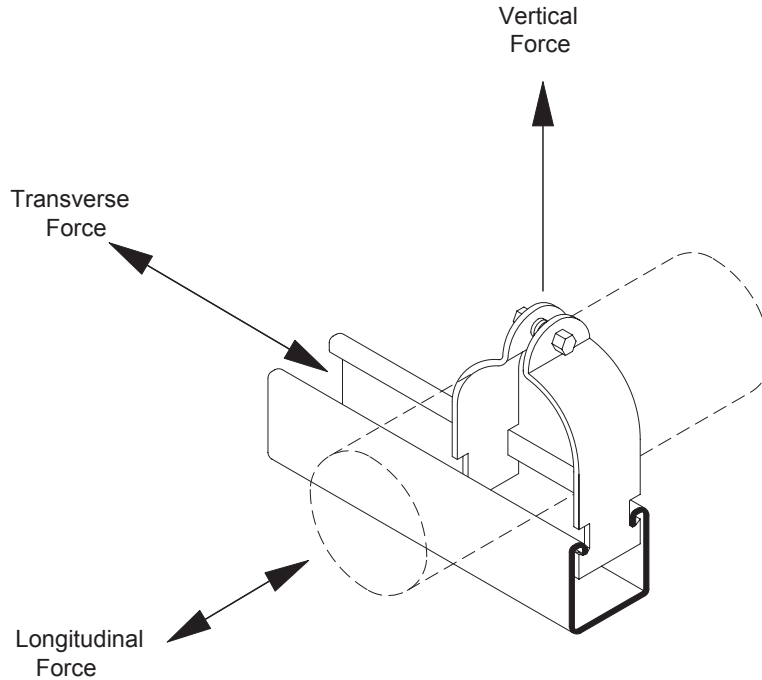

### P1100 Series Pipe Clamps

Unistrut Part Number	Pipe Size		Strap thickness		Screw Size		Vertical Force		Design Loads			
									Transverse Force		Longitudinal Force	
	In.	mm	Ga.	mm	In.	mm	Lbs.	N	Lbs.	N	Lbs.	N
P1111	1/2	13	16	1.5	1/4	6	400	1,780	70	310	50	220
P1112	3/4	19	14	1.9	1/4	6	600	2,670	100	440	70	310
P1113	1	25	14	1.9	1/4	6	600	2,670	150	670	80	360
P1114	1 1/4	32	14	1.9	1/4	6	600	2,670	150	670	150	670
P1115	1 1/2	38	12	2.7	1/4	6	800	3,560	240	1,070	150	670
P1117	2	51	12	2.7	1/4	6	800	3,560	240	1,070	200	890
P1118	2 1/2	64	12	2.7	5/16	8	800	3,560	240	1,070	200	890
P1119	3	76	12	2.7	5/16	8	800	3,560	240	1,070	200	890
P1120	3 1/2	89	11	3	3/8	10	1,000	4,450	320	1,420	200	890
P1121	4	102	11	3	3/8	10	1,000	4,450	320	1,420	200	890
P1123	5	127	11	3	3/8	10	1,000	4,450	320	1,420	200	890
P1124	6	152	10	3.4	3/8	10	1,000	4,450	320	1,420	200	890
P1126	8	203	10	3.4	3/8	10	1,000	4,450	320	1,420	200	890



**UNISTRUT®**

35660 Clinton Street  
 Wayne, Michigan 48184  
 PH: (800) 521-7730  
 FAX: (734) 721-4106

JOSEPH L. LA BRIE  
 Structural Engineer  
 No. SE 3566  
 55 E. Walnut St. Suite 277  
 Arcadia, CA 91006

DATE:

04/25/2003

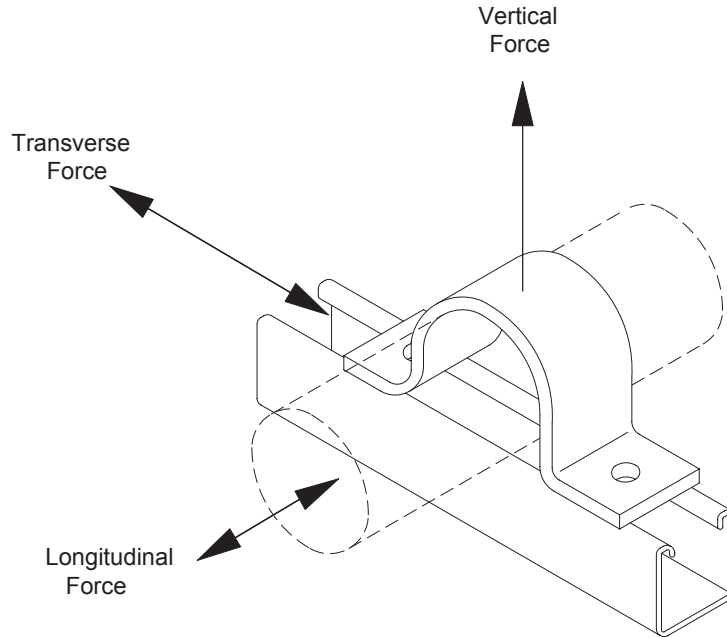

PAGE

3-3

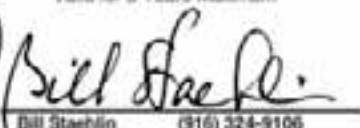

**P558 Series Pipe Clamps**

Unistrut Part Number	Pipe Size		Strap thickness		Screw Size		Design Loads					
							Vertical Force		Transverse Force		Longitudinal Force	
	In.	mm	Ga.	mm	In.	mm	Lbs.	N	Lbs.	N	Lbs.	N
P2558-05	1/2	13	1/8	3	1/4	6	500	2,220	250	1,110	100	440
P2558-07	3/4	19	1/8	3	1/4	6	500	2,220	250	1,110	100	440
P2558-10	1	25	1/8	3	1/4	6	500	2,220	250	1,110	100	440
P2558-12	1 1/4	32	1/8	3	1/4	6	500	2,220	250	1,110	100	440
P2558-15	1 1/2	38	1/8	3	1/4	6	500	2,220	250	1,110	100	440
P2558-20	2	51	1/4	6	3/8	10	1,000	4,450	1,000	4,450	200	890
P2558-25	2 1/2	64	1/4	6	3/8	10	1,000	4,450	1,000	4,450	200	890
P2558-30	3	76	1/4	6	3/8	10	1,000	4,450	1,000	4,450	200	890
P2558-35	3 1/2	89	1/4	6	3/8	10	1,000	4,450	1,000	4,450	200	890
P2558-40	4	102	1/4	6	3/8	10	1,000	4,450	1,000	4,450	200	890
P2558-50	5	127	1/4	6	3/8	10	1,000	4,450	1,000	4,450	200	890
P2558-60	6	152	1/4	6	3/8	10	1,000	4,450	1,000	4,450	275	1,220

<p align="center"><b>APPROVED</b>  <b>Fixed Equipment Anchorage</b>                  Office of Statewide Health Planning and Development</p> <p align="center"><b>OPA-0120 Apr 25, 2003</b></p> <p align="center">**** Valid for 3 Years Maximum ****</p>  <p align="center">Bill Staehlin (916) 324-9106</p>	 <p align="right"><b>UNISTRUT®</b>                  35660 Clinton Street                  Wayne, Michigan 48184                  PH: (800) 521-7730                  FAX: (734) 721-4106</p> <p>JOSEPH L. LA BRIE                  Structural Engineer                  No. SE 3566                  55 E. Walnut St. Suite 277                  Arcadia, CA 91006</p> 
DATE: <b>04/25/2003</b>	PAGE: <b>3-4</b>

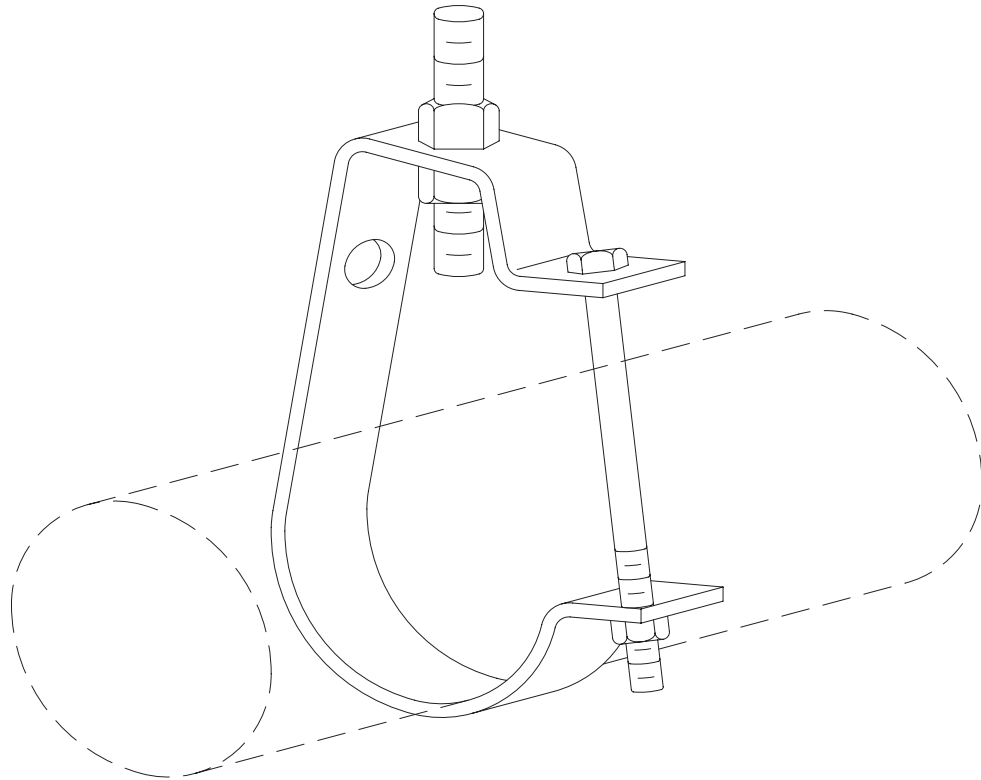

**J1200 Series Pipe Clamps**

Unistrut Part Number	Pipe Size		Strap thickness		Bolt Size		Vertical Adjustment		Design Loads	
	In.	mm	Ga.	mm	In.	mm	In.	mm	Lbs.	N
J1205	1/2	13	1/8 x 3/4	3 x 19	1/4 x 2 1/4	6 x 57	7/8	22	300	1,330
J1207	3/4	19	1/8 x 3/4	3 x 19	1/4 x 2 1/4	6 x 57	7/8	22	300	1,330
J1210	1	25	1/8 x 3/4	3 x 19	1/4 x 2 3/4	6 x 70	1	25	300	1,330
J1212	1 1/4	32	1/8 x 3/4	3 x 19	1/4 x 2 3/4	6 x 83	1 3/8	35	300	1,330
J1215	1 1/2	38	1/8 x 3/4	3 x 19	1/4 x 3 1/2	6 x 89	1 1/2	38	300	1,330
J1220	2	51	1/8 x 3/4	3 x 19	1/4 x 4	6 x 102	1 5/8	41	300	1,330
J1225	2 1/2	64	1/8 x 1 1/4	3 x 32	3/8 x 4 1/2	10 x 114	1 7/8	48	500	2,220
J1230	3	76	1/8 x 1 1/4	3 x 32	3/8 x 5	10 x 127	1 7/8	48	500	2,220
J1235	3 1/2	89	1/8 x 1 1/4	3 x 32	3/8 x 5 1/2	10 x 140	2 1/8	54	500	2,220
J1240	4	102	1/8 x 1 1/4	6 x 32	3/8 x 6 1/2	10 x 165	2 1/4	57	600	2,670
J1250	5	127	1/8 x 1 1/4	6 x 32	3/8 x 7 1/2	10 x 191	2 1/4	57	600	2,670
J1260	6	152	1/8 x 1 1/4	6 x 32	3/8 x 8 1/2	10 x 216	2 5/8	67	600	2,670
J1280	8	203	1/4 x 2	6 x 51	3/8 x 12	10 x 305	4 5/8	117	700	3,110



**UNISTRUT®**

35660 Clinton Street  
Wayne, Michigan 48184  
PH: (800) 521-7730  
FAX: (734) 721-4106

JOSEPH L. LA BRIE  
Structural Engineer  
No. SE 3566  
55 E. Walnut St. Suite 277  
Arcadia, CA 91006

DATE:

04/25/2003

PAGE

3-5

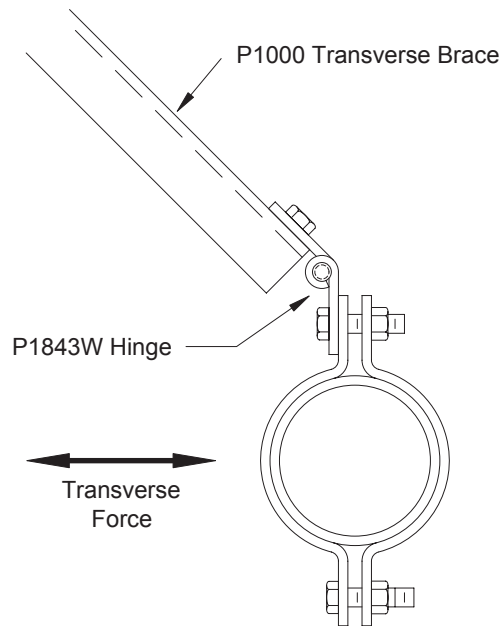

Transverse Brace

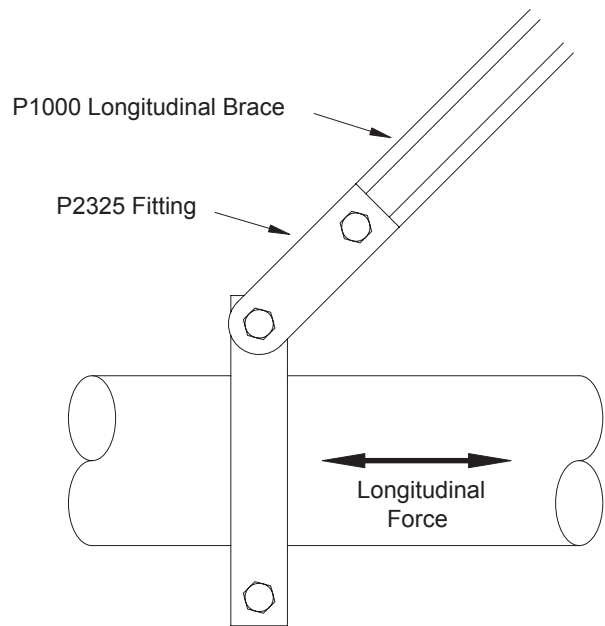

Longitudinal Brace

Clamp (By Others) complies with Federal Spec WW-H-171E Type 4 and MSS SP-58 Type 4

**Design Longitudinal Force**

Pipe Size <i>in.</i>	Longitudinal Force	
	<i>lbs.</i>	<i>kN</i>
½ thru 1 ½	100	0.445
1 ¾ thru 5	200	0.890
6	375	1.670
8	500	2.220



**UNISTRUT®**

35660 Clinton Street  
Wayne, Michigan 48184  
PH: (800) 521-7730  
FAX: (734) 721-4106

JOSEPH L. LA BRIE  
Structural Engineer  
No. SE 3566  
55 E. Walnut St. Suite 277  
Arcadia, CA 91006

DATE:

04/25/2003

PAGE

**3-6**

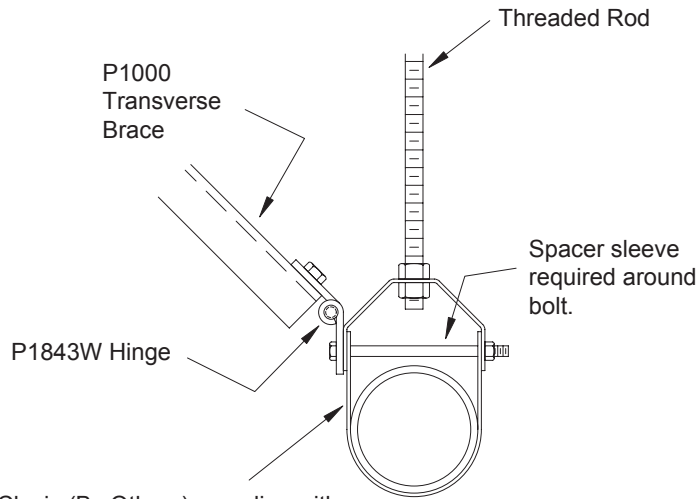

Clevis (By Others) complies with Federal Spec WW-H-171E Type 1 and MSS SP-58 Type 1

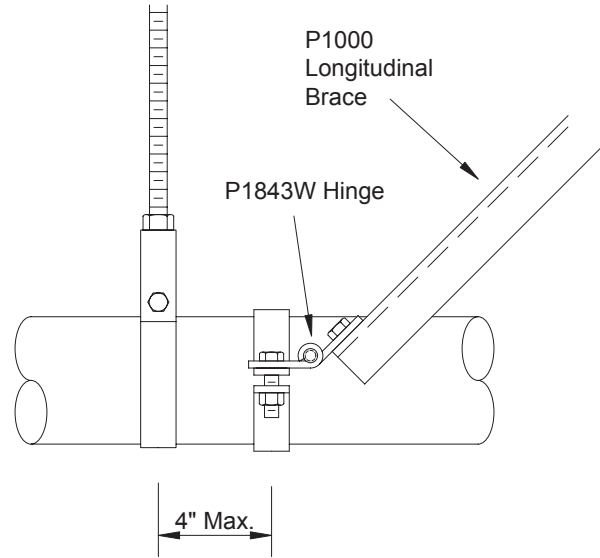

**UNISTRUT®**

35660 Clinton Street  
 Wayne, Michigan 48184  
 PH: (800) 521-7730  
 FAX: (734) 721-4106

JOSEPH L. LA BRIE  
 Structural Engineer  
 No. SE 3566  
 55 E. Walnut St. Suite 277  
 Arcadia, CA 91006

DATE:

04/25/2003

PAGE

3-7

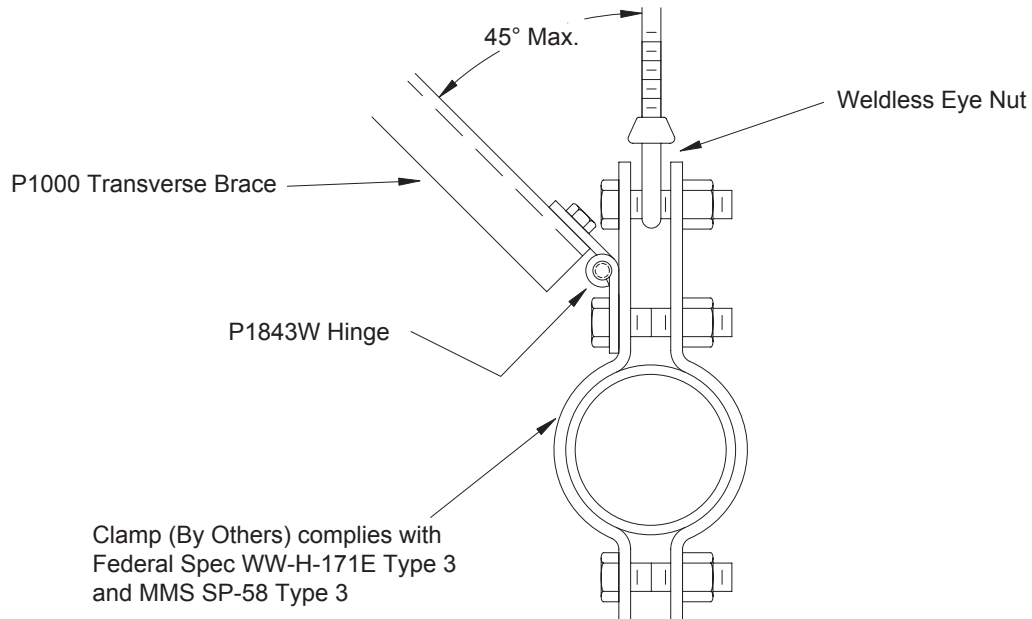

<p style="text-align: center;"><b>A P P R O V E D</b>  <b>Fixed Equipment Anchorage</b>          Office of Statewide Health Planning and Development</p> <p style="text-align: center;"><b>OPA-0120 Apr 25, 2003</b></p> <p style="text-align: center;">**** Valid for 3 Years Maximum ****</p> <p style="text-align: center;"><i>Bill Staehlin</i>          Bill Staehlin (916) 324-9106</p>	<p style="text-align: right;"><b>UNISTRUT®</b>          35660 Clinton Street          Wayne, Michigan 48184          PH: (800) 521-7730          FAX: (734) 721-4106</p> <p style="text-align: center;"><i>Joseph L. LaBrie</i></p> <p>JOSEPH L. LA BRIE          Structural Engineer          No. SE 3566          55 E. Walnut St. Suite 277          Arcadia, CA 91006</p>
<p>DATE: <b>04/25/2003</b></p>	<p>PAGE  <b>3-8</b></p>

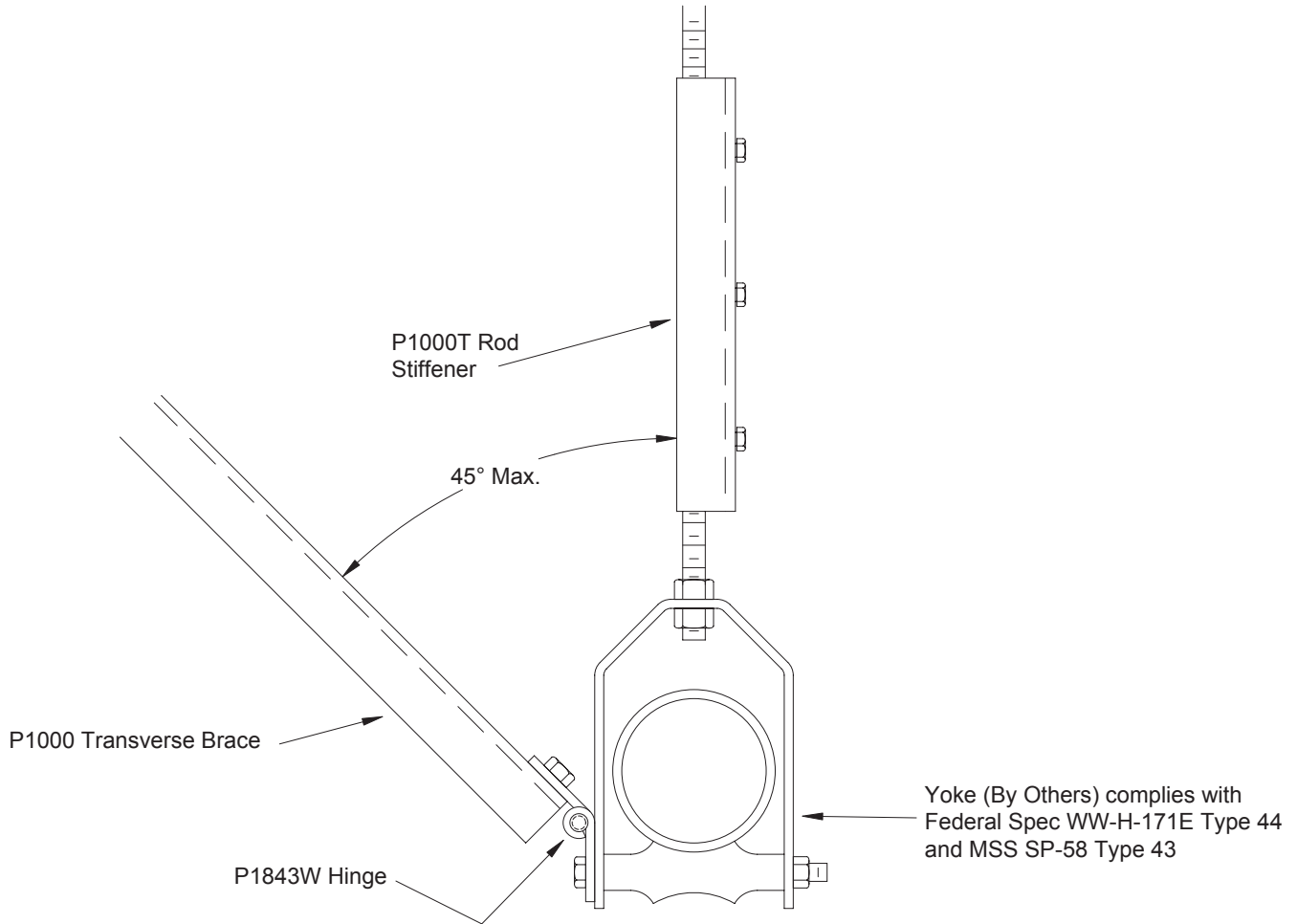

<p style="text-align: center;"><b>A P P R O V E D</b>  <b>Fixed Equipment Anchorage</b>                  Office of Statewide Health Planning and Development</p> <p style="text-align: center;"><b>OPA-0120 Apr 25, 2003</b></p> <p style="text-align: center;">**** Valid for 3 Years Maximum ****</p> <p style="text-align: center;"><i>Bill Staehlin</i>                  Bill Staehlin (916) 324-9106</p>	<p style="text-align: center;"></p> <p style="text-align: right;"><b>UNISTRUT®</b>                  35660 Clinton Street                  Wayne, Michigan 48184                  PH: (800) 521-7730                  FAX: (734) 721-4106</p> <p>JOSEPH L. LA BRIE                  Structural Engineer                  No. SE 3566                  55 E. Walnut St. Suite 277                  Arcadia, CA 91006</p> <p style="text-align: right;"><i>J. LaBrie</i></p>
<p>DATE: <b>04/25/2003</b></p>	<p>PAGE  <b>3-9</b></p>

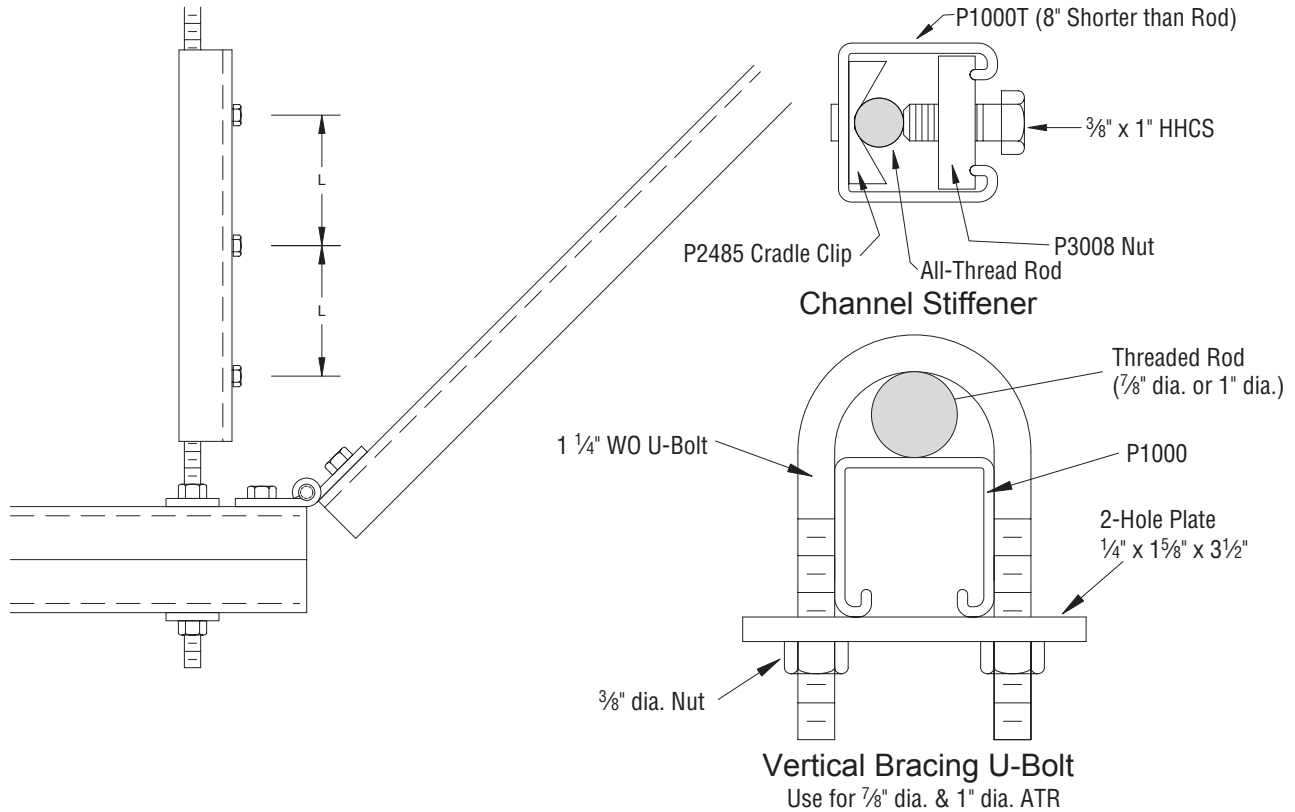

**VERTICAL BRACING OR STIFFENER LOAD TABLE**

Rod Size In.	Root Area In. <sup>2</sup>	Root Diameter In.	Radius of Gyration In.	Max. Allowable Rod Compression Lbs. @ 100%	Clip Spacing L (In.)			Max. Seismic Safe Load* Lbs.
					Rod Stress at 50% 4,500 PSI	Rod Stress at 75% 6,750 PSI	Rod Stress at 100% 9,000 PSI	
3/8	0.068	0.314	0.0785	610	14	12	10	810
1/2	0.126	0.425	0.1063	1,130	20	16	14	1,500
5/8	0.202	0.536	0.1341	1,810	24	20	16	2,410
3/4	0.302	0.652	0.163	2,710	30	24	20	3,610
7/8 <sup>4</sup>	0.419	0.73	0.192	3,770	35	28	25	5,030
1 <sup>4</sup>	0.552	0.838	0.22	4,960	40	33	28	6,610

- Assumptions:
1. Rod held against translation at location of cradle clips K equals 1.0.
  2. L = Distance between connection points.
  3. Trapeze with braces on alternate members.
  4. Must use U-Bolt detail, page 3-11.
  - \*5. Loads are based on the root area of the thread and at a stress of 9,000 psi.
  - \*6. Safe seismic forces are determined by increasing allowable safe loads by 33%

<p style="text-align: center;"><b>APPROVED</b> Fixed Equipment Anchorage Office of Statewide Health Planning and Development</p> <p style="text-align: center;"><b>OPA-0120 Apr 25, 2003</b></p> <p style="text-align: center;">**** Valid for 3 Years Maximum ****</p> <p style="text-align: center;"><i>Bill Stashin</i> Bill Stashin (916) 324-9106</p>	<p style="text-align: right;"><b>UNISTRUT®</b> 35660 Clinton Street Wayne, Michigan 48184 PH: (800) 521-7730 FAX: (734) 721-4106</p> <p style="text-align: center;"><i>Joseph L. LaBrie</i></p> <p>JOSEPH L. LA BRIE Structural Engineer No. SE 3566 55 E. Walnut St. Suite 277 Arcadia, CA 91006</p>
<p>DATE: <b>04/25/2003</b></p>	<p>PAGE <b>3-10</b></p>

P1000

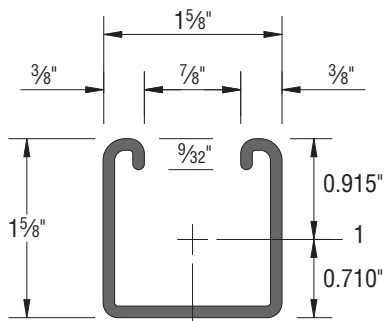
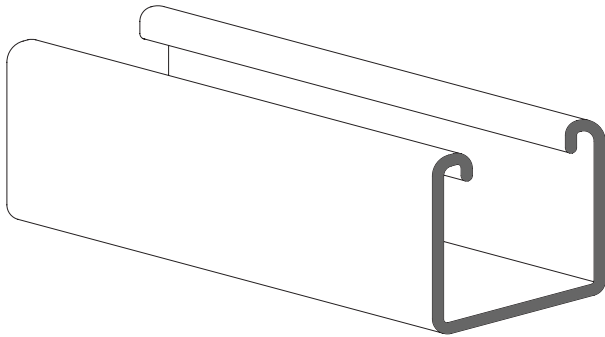

2

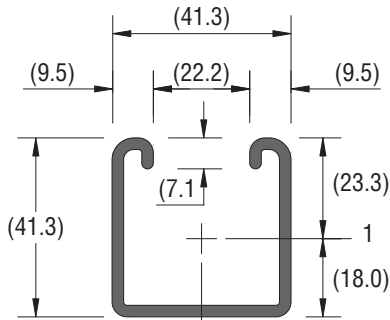

2

NOTE: CHANNEL WALL THICKNESS IS 12GA. (0.105")  
 UNITS IN PARENTHESIS ARE METRIC (mm)

P5500

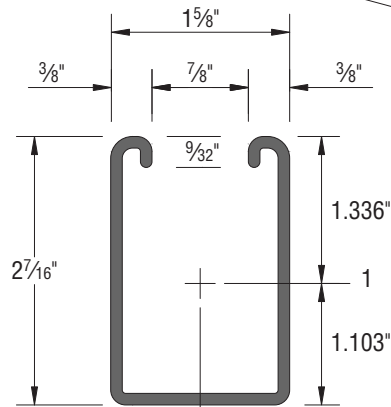
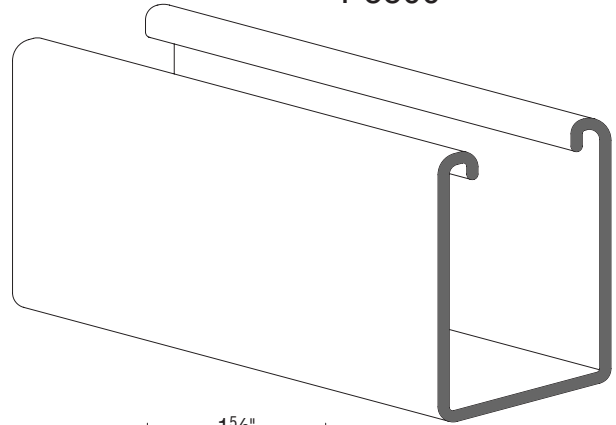

2

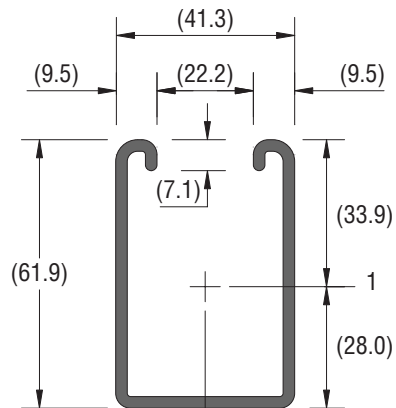

2



JOSEPH L. LA BRIE  
 Structural Engineer  
 No. SE 3566  
 55 E. Walnut St. Suite 277  
 Arcadia, CA 91006

**UNISTRUT®**

35660 Clinton Street  
 Wayne, Michigan 48184  
 PH: (800) 521-7730  
 FAX: (734) 721-4106

DATE:

04/25/2003

PAGE

4-1

P1001AW

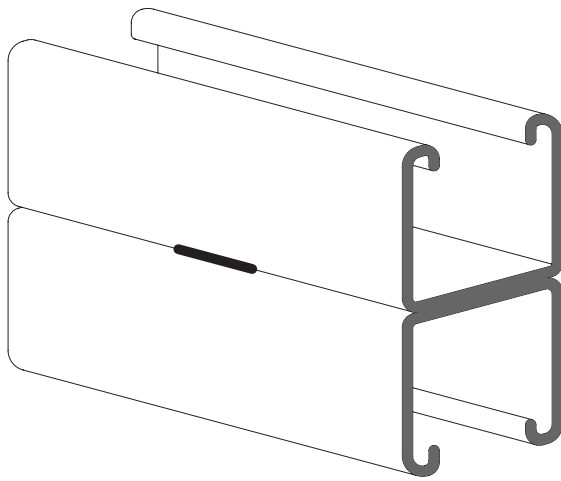

P5501AW

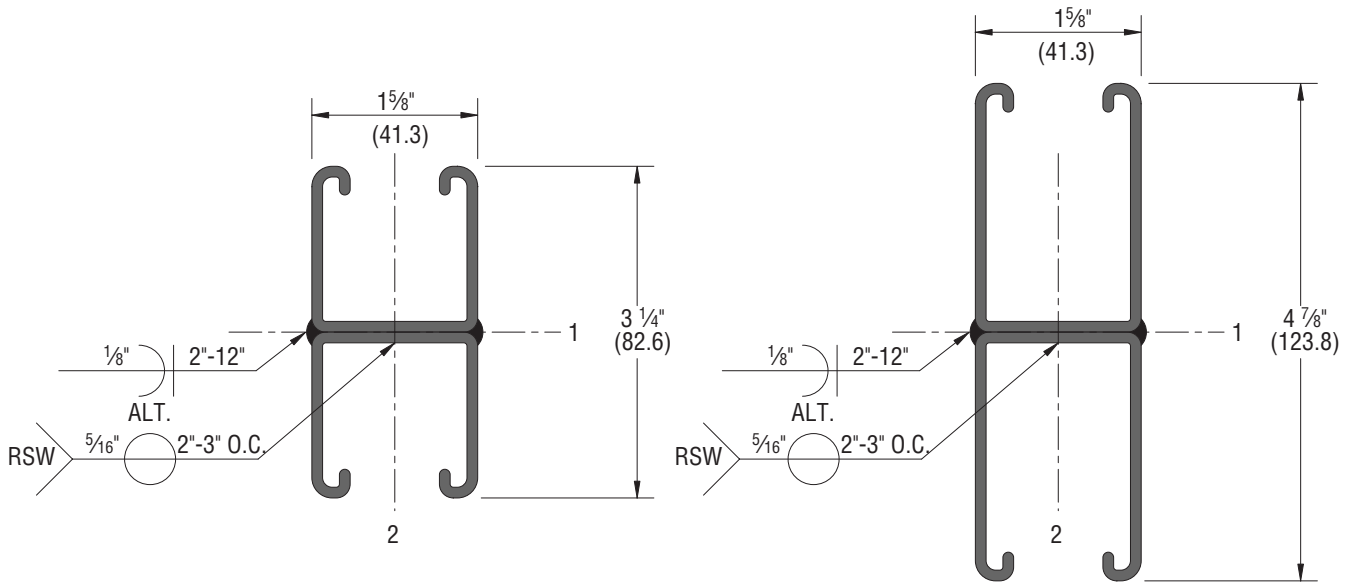
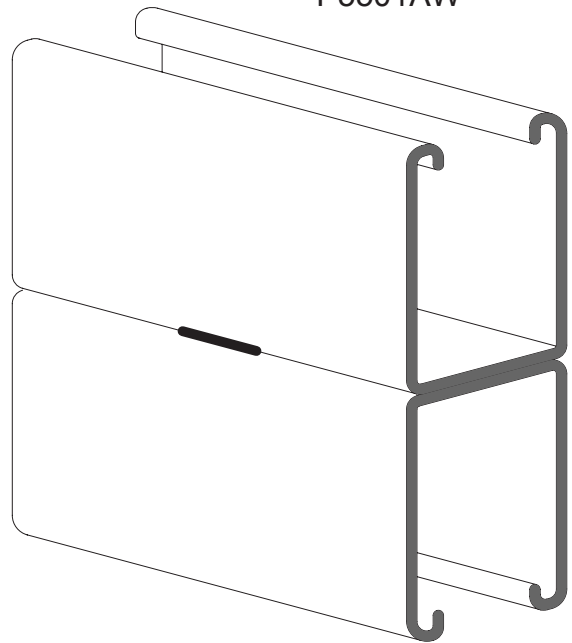

NOTE: CHANNEL WALL THICKNESS IS 12GA. (0.105")  
 UNITS IN PARENTHESIS ARE METRIC (mm)

<p style="text-align: center;"><b>APPROVED</b>  <b>Fixed Equipment Anchorage</b>                  Office of Statewide Health Planning and Development</p> <p style="text-align: center;"><b>OPA-0120 Apr 25, 2003</b></p> <p style="text-align: center;">**** Valid for 3 Years Maximum ****</p> <p style="text-align: center;"><i>Bill Staehlin</i>                  Bill Staehlin (916) 324-9106</p>	<p style="text-align: right;"><b>UNISTRUT®</b>                  35660 Clinton Street                  Wayne, Michigan 48184                  PH: (800) 521-7730                  FAX: (734) 721-4106</p> <p>JOSEPH L. LA BRIE                  Structural Engineer                  No. SE 3566                  55 E. Walnut St. Suite 277                  Arcadia, CA 91006</p> 
<p>DATE: <b>04/25/2003</b></p>	<p>PAGE  <b>4-2</b></p>

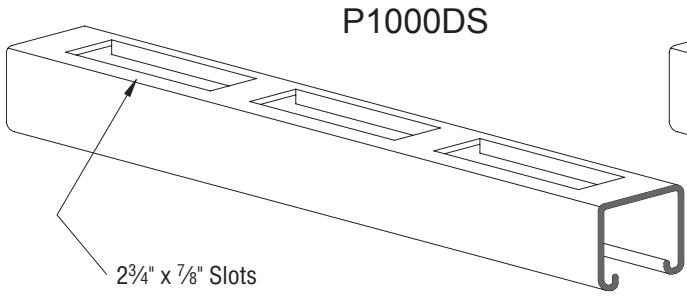

P1000DS

**P1000DS**  
For Beam Load Capacity,  
Use 70% of P1000 Load Table

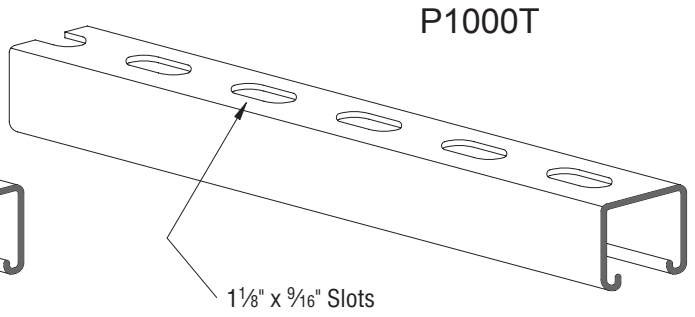

P1000T

**P1000T**  
For Beam Load Capacity,  
Use 85% of P1000 Load Table

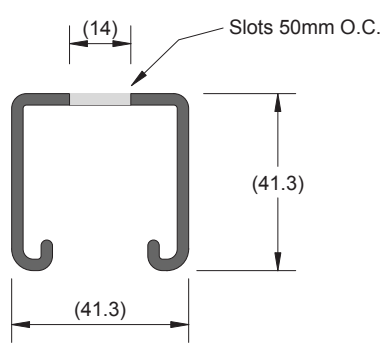
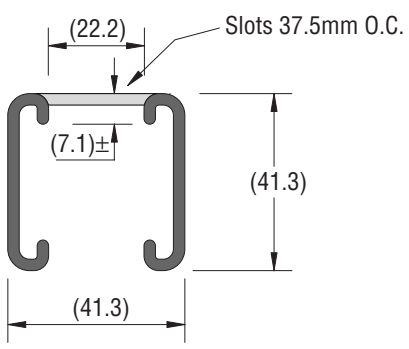
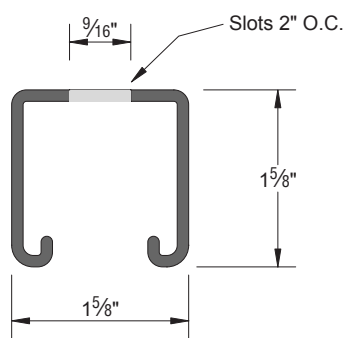
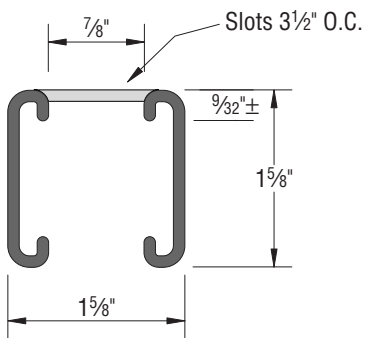

NOTE: CHANNEL WALL THICKNESS IS 12GA. (0.105")  
UNITS IN PARENTHESIS ARE METRIC (mm)

**APPROVED**  
**Fixed Equipment Anchorage**  
Office of Statewide Health Planning and Development

**OPA-0120 Apr 25, 2003**

\*\*\*\* Valid for 3 Years Maximum \*\*\*\*

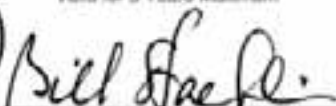

  
 Bill Staehlin (916) 324-9106



**UNISTRUT®**  
35660 Clinton Street  
Wayne, Michigan 48184  
PH: (800) 521-7730  
FAX: (734) 721-4106

JOSEPH L. LA BRIE  
Structural Engineer  
No. SE 3566  
55 E. Walnut St. Suite 277  
Arcadia, CA 91006



DATE: **04/25/2003**

PAGE  
**4-3**

**Table 15 – ELEMENTS OF SECTION**

Channel Type	Weight		A		Axis, 1 - 1						Axis, 2 - 2					
	Lbs./Ft.	Kg/m	in <sup>2</sup>	cm <sup>2</sup>	I		S		R		I		S		R	
					in <sup>4</sup>	cm <sup>4</sup>	in <sup>3</sup>	cm <sup>3</sup>	in	cm	in <sup>4</sup>	cm <sup>4</sup>	in <sup>3</sup>	cm <sup>3</sup>	in	cm
P1000	1.89	2.81	0.556	3.59	0.185	7.7	0.202	3.31	0.577	1.466	0.236	9.82	0.29	4.75	0.651	1.65
P1001	3.78	5.62	1.112	7.17	0.93	38.71	0.572	9.37	0.915	2.324	0.472	19.65	0.58	9.5	0.651	1.65
P5500	2.47	3.68	0.726	4.68	0.523	21.77	0.391	6.41	0.848	2.154	0.335	13.94	0.412	6.75	0.679	1.72
P5501	4.94	7.35	1.453	9.37	2.811	117	1.153	18.89	1.391	3.533	0.669	27.85	0.824	13.5	0.679	1.72



**Static Beam Load (X-X Axis)**

Span	Channel	Max Allowable Uniform Load (Lbs)		Deflection at Uniform Load (In)		Max Allowable Horizontal Load (Lbs)		Lateral Buckling Reduction Factor
		Lbs.	N	in.	mm	Lbs.	N	
24in (610 mm)	P1000	1,690	7,520	0.06	1.5	2,430	10,800	0.92
	P1001	3130*	13920*	0.03	0.8	3130*	13900*	0.98
	P5500	3,280	14,590	0.04	1	3450	15,300	0.91
	P5501	4680*	20820*	0.02	0.5	4680*	20800*	0.98
36 (914mm)	P1000	1,130	5,030	0.13	3.3	1,620	7,200	0.86
	P1001	3130*	13920*	0.07	1.8	3130*	13900*	0.96
	P5500	2,190	9,740	0.09	2.3	2300	10,200	0.82
	P5501	4680*	20820*	0.05	1.3	4610	20,500	0.95
48 (1,219mm)	P1000	850	3,780	0.22	5.6	1,220	5,400	0.81
	P1001	2,400	10,680	0.13	3.3	2430	10,800	0.93
	P5500	1,640	7,300	0.15	3.8	1730	7,700	0.74
	P5501	4680*	20820*	0.08	2	3450	15,300	0.92
60in (1,524mm)	P1000	680	3,020	0.35	8.9	970	4,300	0.76
	P1001	1,920	8,540	0.2	5.1	1940	8,600	0.9
	P5500	1,310	5,830	0.24	6.1	1380	6,100	0.66
	P5501	3,870	17,210	0.13	3.3	2760	12,300	0.88
72in (1,829mm)	P1000	560	2,490	0.5	12.7	810	3,600	0.73
	P1001	1,600	7,120	0.28	7.1	1620	7,200	0.87
	P5500	1,090	4,850	0.34	8.6	1150	5,100	0.6
	P5501	3,220	14,320	0.19	4.8	2300	10,200	0.84
84in (2,134mm)	P1000	480	2,140	0.68	17.3	690	3,100	0.7
	P1001	1,370	6,090	0.39	9.9	1390	6,200	0.84
	P5500	940	4,180	0.47	11.9	990	4,400	0.55
	P5501	2,760	12,280	0.26	6.6	1970	8,800	0.8
96in (2,438mm)	P1000	420	1,870	0.89	22.6	610	2,700	0.67
	P1001	1,200	5,340	0.5	12.7	1220	5,400	0.81
	P5500	820	3,650	0.61	15.5	860	3,800	0.5
	P5501	2,420	10,760	0.34	8.6	1730	7,700	0.75
108in (2,743mm)	P1000	380	1,690	1.13	28.7	540	2,400	0.65
	P1001	1,070	4,760	0.64	16.3	1080	4,800	0.78
	P5500	730	3,250	0.77	19.6	770	3,400	0.46
	P5501	2,150	9,560	0.42	10.7	1540	6,900	0.71
120in (3,048mm)	P1000	340	1,510	1.4	35.6	490	2,200	0.63
	P1001	960	4,270	0.79	20.1	970	4,300	0.74
	P5500	660	2,940	0.96	24.4	690	3,100	0.43
	P5501	1,930	8,590	0.52	13.2	1380	6,100	0.66

**Notes:**

- Calculations of section properties are based on metal thicknesses as determined by AISI, Cold-Form Steel Design Manual
- Prevent end rotation of beams that have vertical loads and lateral forces.
- When loads are concentrated at or near midspan, allowable uniform loads should be multiplied by 0.5 and deflections by 0.8
- Laterally unbraced beams should have allowable loads reduced by multiplying by the load reduction factor given in the last column.
- For short term seismic conditions apply a 33% increase in allowable loads.

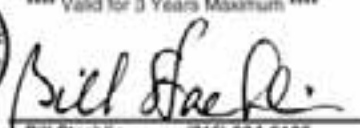
\* Load Limited by Weld Shear

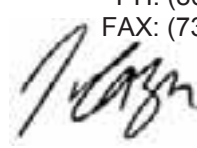
<p><b>APPROVED</b> Fixed Equipment Anchorage Office of Statewide Health Planning and Development</p> <p><b>OPA-0120 Apr 25, 2003</b></p> <p>**** Valid for 3 Years Maximum ****</p>  Bill Staehlin (916) 324-9106		<p><b>UNISTRUT®</b> 35660 Clinton Street Wayne, Michigan 48184 PH: (800) 521-7730 FAX: (734) 721-4106</p>
	<p>JOSEPH L. LA BRIE Structural Engineer No. SE 3566 55 E. Walnut St. Suite 277 Arcadia, CA 91006</p> 	<p>DATE: <b>04/25/2003</b></p>

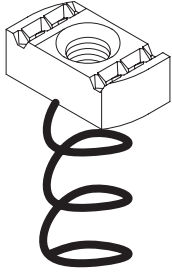

Spring Nut  
P1006-1420  
P1008  
P1010

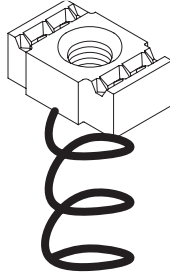

Spring Nut  
P1023S  
P1012S  
-

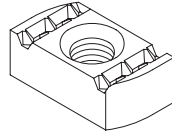

Nut Without Spring  
P3006-1420  
P3008  
P3010

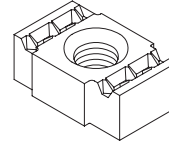

Nut Without Spring  
P1023  
P1012  
-

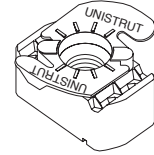

Nut with  
Top Retainer  
P1006-1420T  
P1008T  
P1010T

### UNISTRUT NUT DIMENSION & DESIGN LOADS

Channel nut	Thread Size	Nut Thickness		Resistance to Slip 12 Ga. Channel		Pull-Out Strength* 12 Ga. Channel		Tightening Torque** 12 Ga. Channel	
		in.	mm	Lbs.	N	Lbs.	N	(ft-lbs)	(N-m)
P1023S P1023	3/4" - 10	3/4"	13	1,700	7,560	2,500	11,120	125	170.00
P1012S P1012	5/8" - 11	5/8"	13	1,500	6,670	2,500	11,120	100	135.00
P1010 P3010 P1010T	1/2" - 13	1/2"	13	1,500	6,670	2,000	8,900	50	70.00
P1008 P3008 P1008T	3/8" - 16	3/8"	10	800	3,560	1,000	4,450	19	25.00
P1006-1420 P3006-1420 P1006-1420T	1/4" - 20	1/4"	6	300	1,330	600	2,670	6	8.00

\*Safety factor of 3

\*\*UNISTRUT nuts and bolts mounted to the UNISTRUT channels must be tightened to listed torque values (unless otherwise noted).

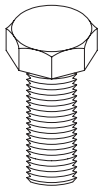

Hex Head Cap Screw  
HHCS

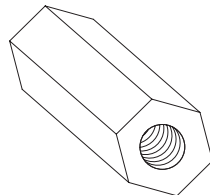

Coupler Nut  
HRCN

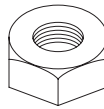

Hex Nut  
HHXN



Lock Washer  
HLKW

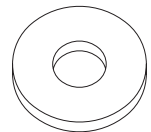

Flat Washer  
HFLW



JOSEPH L. LA BRIE  
Structural Engineer  
No. SE 3566  
55 E. Walnut St. Suite 277  
Arcadia, CA 91006

**UNISTRUT®**

35660 Clinton Street  
Wayne, Michigan 48184  
PH: (800) 521-7730  
FAX: (734) 721-4106

DATE:

04/25/2003

PAGE

4-5

**P1000 BRACE DESIGN LOAD**

Unsupported Length	Compression Load*	
	<i>in (mm)</i>	<i>lbs</i>
24 (610)	4,200	18.50
36 (914)	3,650	16.00
48 (1219)	3,130	13.50
60 (1524)	2,650	11.50
72 (1829)	2,230	9.50
84 (2134)	1,850	8.00
96 (2438)	1,570	6.50
108 (2743)	1,360	6.00
120 (3048)	1,200	5.00



\*Note: 1. Maximum axial load under seismic loading conditions.  
2. The design load shall not exceed the allowable loads for connection detail.

**SPF 400 DESIGN LOAD**

\* A Trademark of Lord & Sons, Inc.

Wire Rope Diameter in (mm)	4 Way Splayed				Single Cable	
	Transverse Load		Longitudinal Load		Transverse Load	
	<i>lbs</i>	<i>(kN)</i>	<i>lbs</i>	<i>(kN)</i>	<i>(lbs)</i>	<i>(kN)</i>
3/16 (5)	1050	4.67	1116	4.96	650	2.89

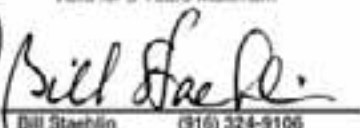
Note: 1. Allowable loads have been determined by the manufacturer's testing, analysis, and technical specifications.  
2. Galvanized Wire Rope, 7 x 19 IWSC, RHRL (PRESTRETCHED)  
3. Maximum torque on nut: 50 ft-lbs.  
4. Safety Factor of 3 for prestretched cable.

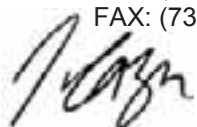
<p align="center"><b>A P P R O V E D</b> <b>Fixed Equipment Anchorage</b> Office of Statewide Health Planning and Development</p> <p align="center"><b>OPA-0120 Apr 25, 2003</b></p> <p align="center">**** Valid for 3 Years Maximum ****</p>  <p align="center">Bill Staehlin (916) 324-9106</p>	 <p align="right"><b>UNISTRUT®</b> 35660 Clinton Street Wayne, Michigan 48184 PH: (800) 521-7730 FAX: (734) 721-4106</p> <p>JOSEPH L. LA BRIE Structural Engineer No. SE 3566 55 E. Walnut St. Suite 277 Arcadia, CA 91006</p> 		
<table border="1"> <tr> <td data-bbox="852 1892 1380 1982">DATE: 04/25/2003</td> <td data-bbox="1380 1892 1474 1982">PAGE 4-6</td> </tr> </table>		DATE: 04/25/2003	PAGE 4-6
DATE: 04/25/2003	PAGE 4-6		

### \*P2815 Adjustable Brace

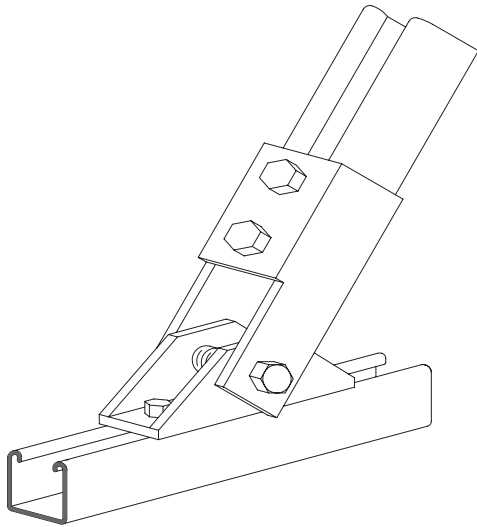

### \*P1843W Adjustable Hinge

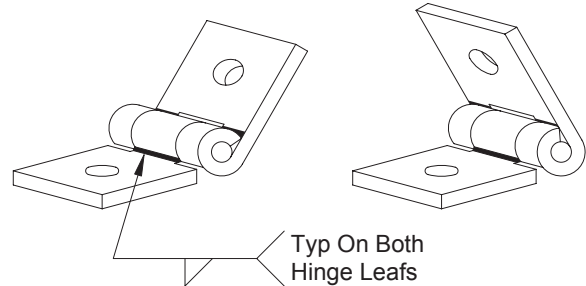

- \*Note:
1. The load capacity of the fitting exceeds the slip and pull-out capacity of the bolt in the channel.
  2. Allowable loads have been determined by the manufacturers testing, analysis and technical specifications

### P2785 Beam Clamp

Use In Pairs

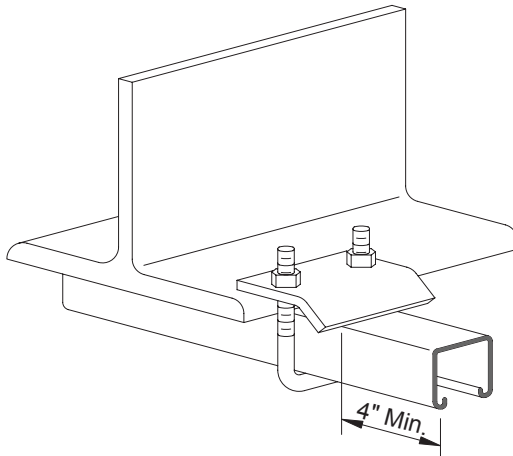

<p style="text-align: center;"><b>A P P R O V E D</b>  <b>Fixed Equipment Anchorage</b>          Office of Statewide Health Planning and Development</p> <p style="text-align: center;"><b>OPA-0120 Apr 25, 2003</b></p> <p style="text-align: center;">**** Valid for 3 Years Maximum ****</p> <p style="text-align: center;"><i>Bill Staehlin</i>          Bill Staehlin (916) 324-9106</p>	<p style="text-align: center;"></p> <p style="text-align: right;"><b>UNISTRUT®</b>          35660 Clinton Street          Wayne, Michigan 48184          PH: (800) 521-7730          FAX: (734) 721-4106</p> <p>JOSEPH L. LA BRIE          Structural Engineer          No. SE 3566          55 E. Walnut St. Suite 277          Arcadia, CA 91006</p> <p style="text-align: right;"><i>J. LaBrie</i></p>
<p>DATE: <b>04/25/2003</b></p>	<p>PAGE  <b>4-7</b></p>

**SERIES SPF100\* FITTING**

For rod sizes: 3/8", 1/2", 5/8", & 3/4"

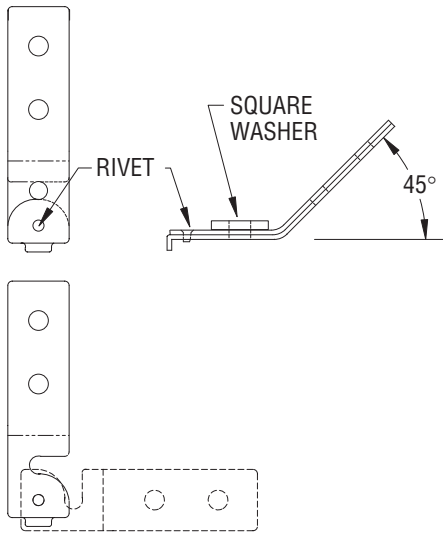

**SERIES SPF200\* ADJUSTABLE FITTING**

For rod sizes: 3/8", 1/2", 5/8", & 3/4"

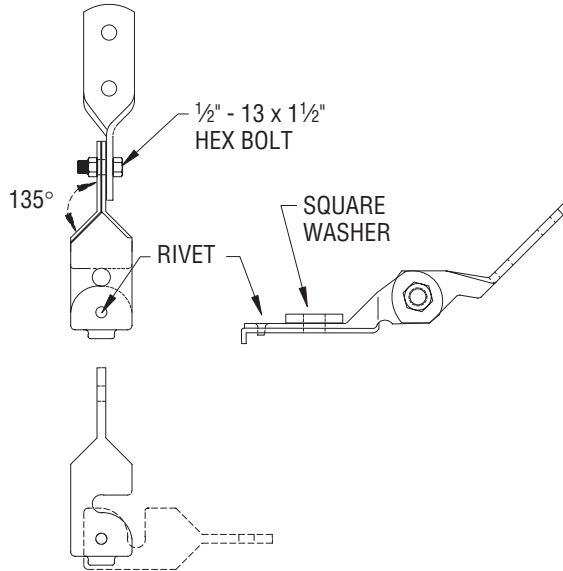

**SERIES SPF300\* FITTING**

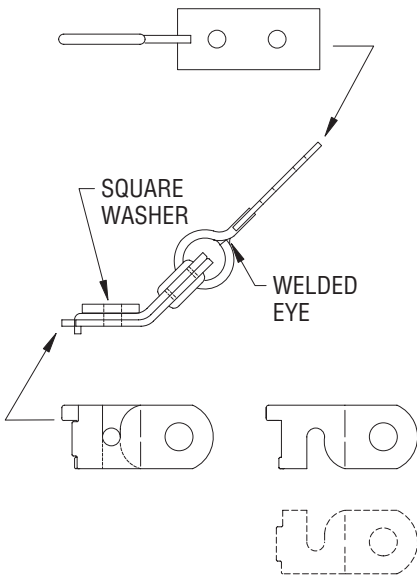

For rod sizes: 3/8", 1/2", 5/8", & 3/4"



**\*SEISMIC PIVOT FITTING (SPF) SERIES**

Note:

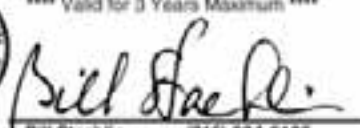
1. The load capacity of the fitting exceeds the slip and pull-out capacity of the bolt in the channel.
2. Allowable loads have been determined by the manufacturers testing, analysis and technical specifications.
3. For retrofit application, engineer of record must verify.
4. Patent Pending.
5. Square washer provided with fitting.
- \*6. A trademark of Lord & Sons, Inc.

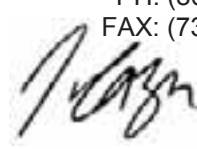
<p><b>APPROVED</b>  <b>Fixed Equipment Anchorage</b>                  Office of Statewide Health Planning and Development</p> <p><b>OPA-0120 Apr 25, 2003</b></p> <p>**** Valid for 3 Years Maximum ****</p>  Bill Stashin (916) 324-9106	<div style="text-align: right;">  <p><b>UNISTRUT®</b>                      35660 Clinton Street                      Wayne, Michigan 48184                      PH: (800) 521-7730                      FAX: (734) 721-4106</p> </div> <div style="margin-top: 20px;"> <p>JOSEPH L. LA BRIE                      Structural Engineer                      No. SE 3566                      55 E. Walnut St. Suite 277                      Arcadia, CA 91006</p>  </div>
<p>DATE: <b>04/25/2003</b></p>	<p>PAGE: <b>4-8</b></p>



**SERIES SPF 400\***

For rod sizes: 3/8", 1/2", 5/8", & 3/4"

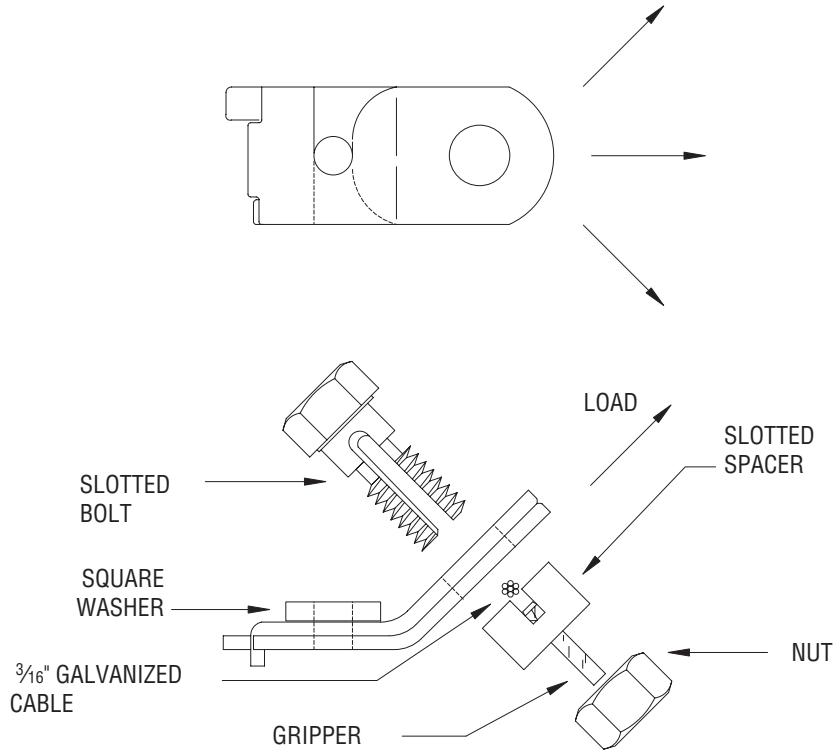

**\*SEISMIC PIVOT FITTING (SPF) SERIES**

Note:

1. For Design loads see Page 4-6.
2. Conforms with FED. SPEC. RRW410
3. For retrofit application, engineer of record must verify.
4. Patent Pending.
5. Square washer provided with fitting
- \*6. A trademark of Lord & Sons, Inc.

<div style="border: 1px solid black; padding: 5px; text-align: center;"> <p><b>A P P R O V E D</b>  <b>Fixed Equipment Anchorage</b>                  Office of Statewide Health Planning and Development</p> <p><b>OPA-0120 Apr 25, 2003</b></p> <p>**** Valid for 3 Years Maximum ****</p> <p><i>Bill Staehlin</i>                  Bill Staehlin (916) 324-9106</p> </div>	<div style="display: flex; justify-content: space-between;"> <div style="text-align: right;"> <p><b>UNISTRUT</b><sup>®</sup>                      35660 Clinton Street                      Wayne, Michigan 48184                      PH: (800) 521-7730                      FAX: (734) 721-4106</p> </div> </div> <p>JOSEPH L. LA BRIE                  Structural Engineer                  No. SE 3566                  55 E. Walnut St. Suite 277                  Arcadia, CA 91006</p>		
DATE:	04/25/2003	PAGE	4-9

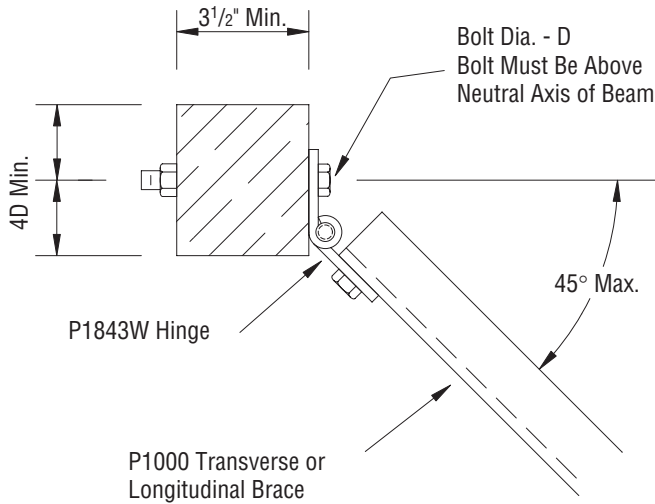

NOTE:

- 1) ABOVE DETAILS INDICATE HOW BRACES MAY BE ATTACHED TO THE STRUCTURE. IF BRACE ANGLE IS GREATER THAN 45° WITH THE HORIZONTAL, ALLOWABLE LOADING MUST BE DETERMINED BY THE PROJECT ENGINEER.
- 2) THE PROJECT ENGINEER SHALL DETERMINE THAT THE WOOD MEMBERS AND ATTACHEMENTS ARE ADEQUATE TO RESIST THE SEISMIC FORCES.

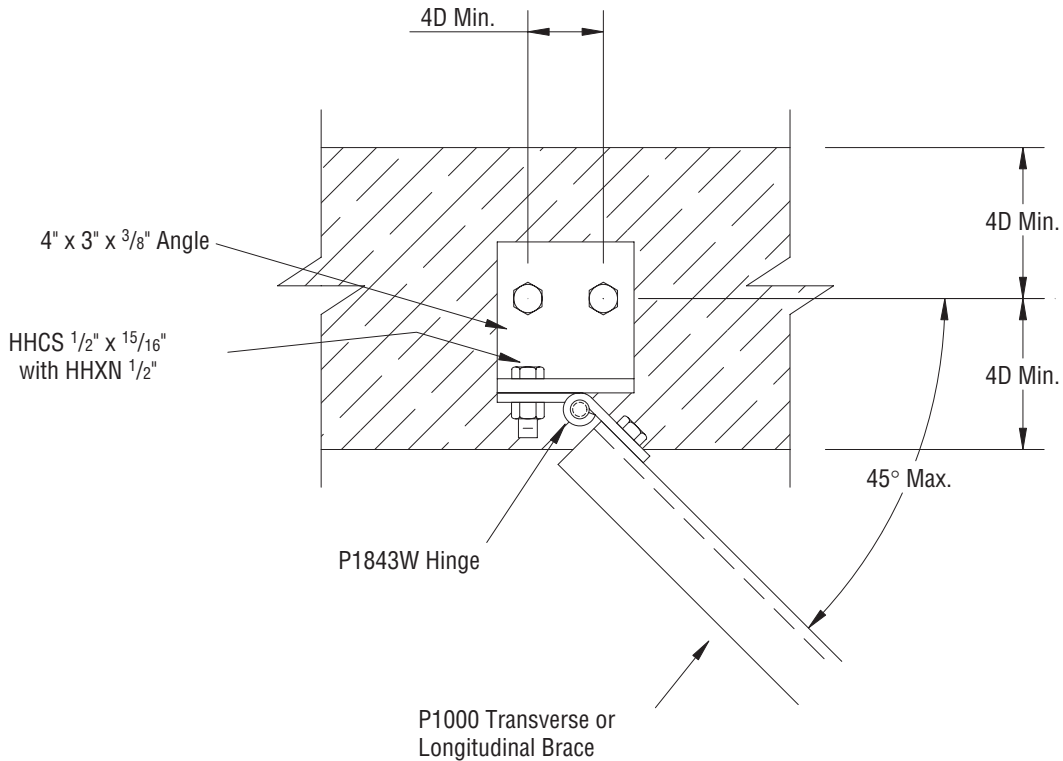

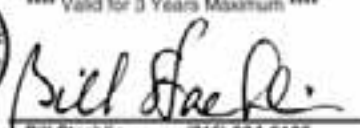
<p><b>APPROVED</b>  <b>Fixed Equipment Anchorage</b>                  Office of Statewide Health Planning and Development</p> <p><b>OPA-0120 Apr 25, 2003</b></p> <p>**** Valid for 3 Years Maximum ****</p>  Bill Stanbin (916) 324-9106	<p><b>UNISTRUT®</b>                  35660 Clinton Street                  Wayne, Michigan 48184                  PH: (800) 521-7730                  FAX: (734) 721-4106</p> <p><i>Joseph L. LaBrie</i></p> <p>JOSEPH L. LA BRIE                  Structural Engineer                  No. SE 3566                  55 E. Walnut St. Suite 277                  Arcadia, CA 91006</p>
<p>DATE: <b>04/25/2003</b></p>	<p>PAGE: <b>5-1</b></p>

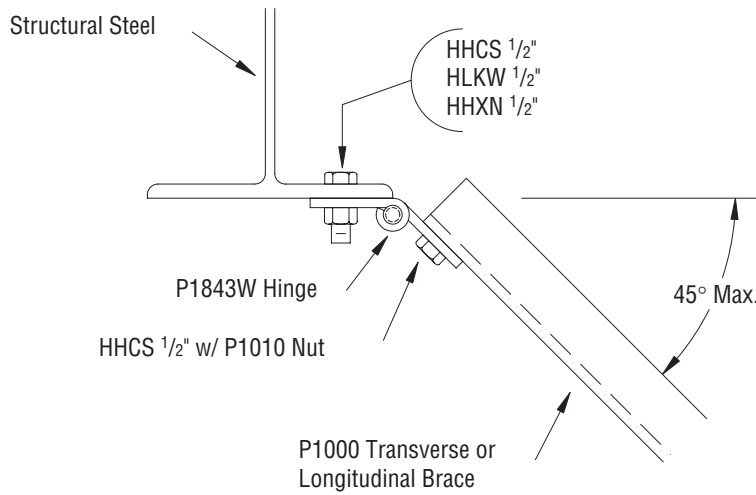

Note: 1) Above details indicate how braces may be attached to the structure. If brace angle is greater than 45° with the horizontal, allowable loading must be determined by the project engineer.

2) The project engineer shall determine that the steel members are adequate to resist the seismic forces.

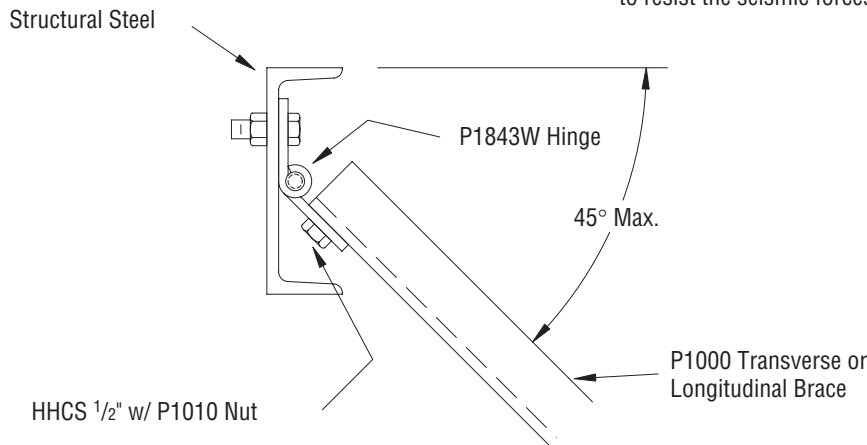

**UNISTRUT®**

35660 Clinton Street  
Wayne, Michigan 48184  
PH: (800) 521-7730  
FAX: (734) 721-4106

JOSEPH L. LA BRIE  
Structural Engineer  
No. SE 3566  
55 E. Walnut St. Suite 277  
Arcadia, CA 91006

DATE:

04/25/2003

PAGE

5-2

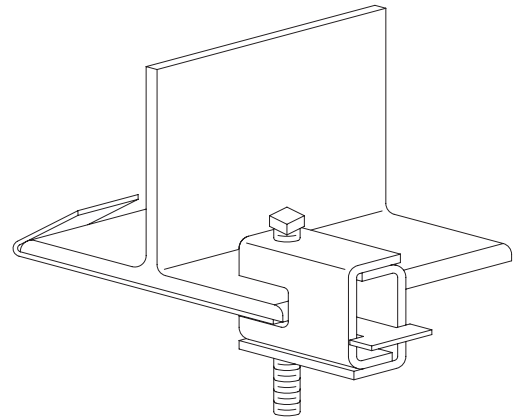
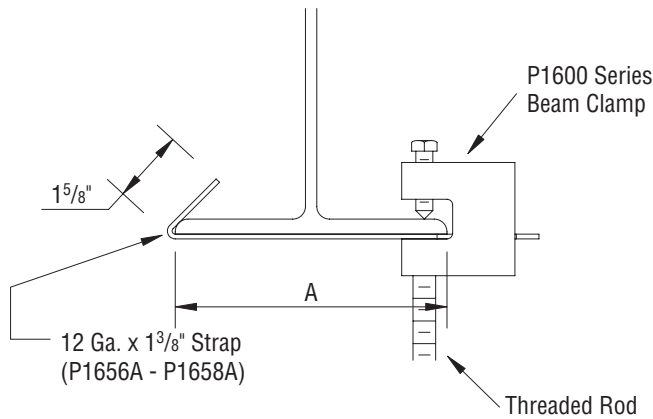

Clamp Number	Size Rod	Size Set Screw	Design Load	Torque Set Screw
P1649AS	3/8"	3/8"	650 lbs	60 in-lbs
P1650AS	1/2"	1/2"	1,100 lbs	125 in-lbs
P1651AS	5/8"	1/2"	1,600 lbs	125 in-lbs

Number Strap	Dim. "A"
P1656A	6"
P1657A	9"
P1658A	12"

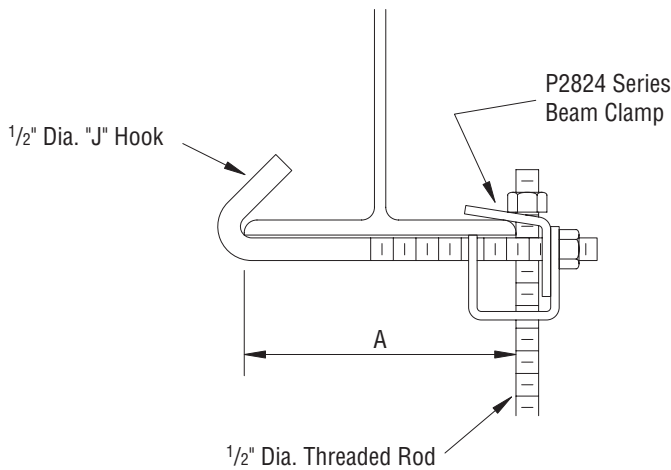

**DESIGN LOAD = 500 lbs**

Number Clamp	"A" Dimension
P2824-6	2 1/2" -6"
P2824-9	5 1/2" -9"
P2824-12	8 1/2" -12"



**UNISTRUT®**

35660 Clinton Street  
Wayne, Michigan 48184  
PH: (800) 521-7730  
FAX: (734) 721-4106

JOSEPH L. LA BRIE  
Structural Engineer  
No. SE 3566  
55 E. Walnut St. Suite 277  
Arcadia, CA 91006

DATE:

04/25/2003

PAGE

5-3

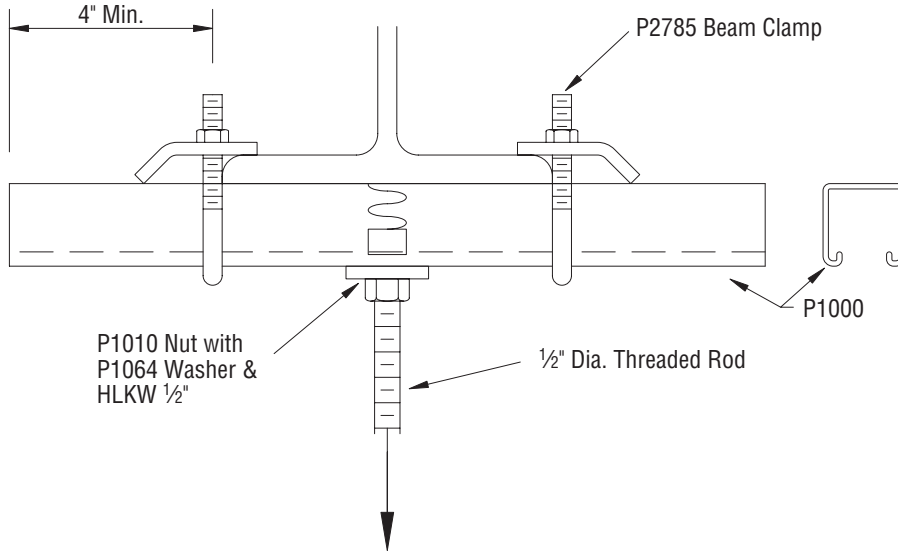

1,130 lbs Design Load

Note: The Engineer of Record shall verify the adequacy of the steel beams.

### Structural Welding Lug

Approvals: Complies with MSS SP-58 Type 57.

Design Load: 1,130 lbs (5.02 kN). Load must be in plane of welding lug.

NOTE: Welding shall be performed by qualified welders and shall be inspected by an independent laboratory. Support the existing beam while field welding lug.

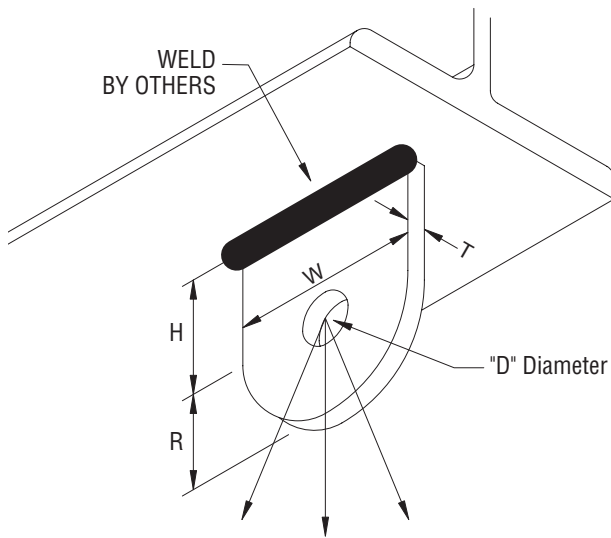

1,130 lbs Design Load

"D" Diameter	1 <sup>1</sup> / <sub>16</sub> "	17mm
H	1 <sup>1</sup> / <sub>2</sub> "	38mm
R	1 <sup>1</sup> / <sub>4</sub> "	32mm
T	1 <sup>1</sup> / <sub>4</sub> "	6mm
W	2 <sup>1</sup> / <sub>2</sub> "	62mm



### UNISTRUT®

35660 Clinton Street  
Wayne, Michigan 48184  
PH: (800) 521-7730  
FAX: (734) 721-4106

JOSEPH L. LA BRIE  
Structural Engineer  
No. SE 3566  
55 E. Walnut St. Suite 277  
Arcadia, CA 91006

DATE:

04/25/2003

PAGE

5-4

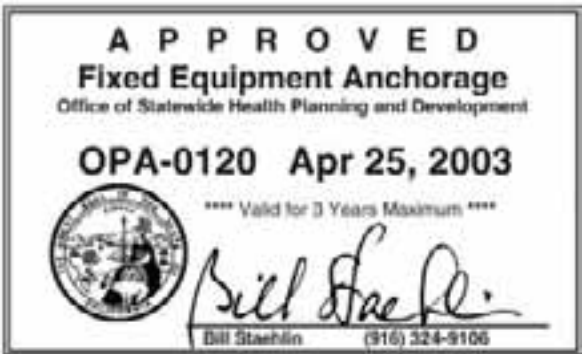
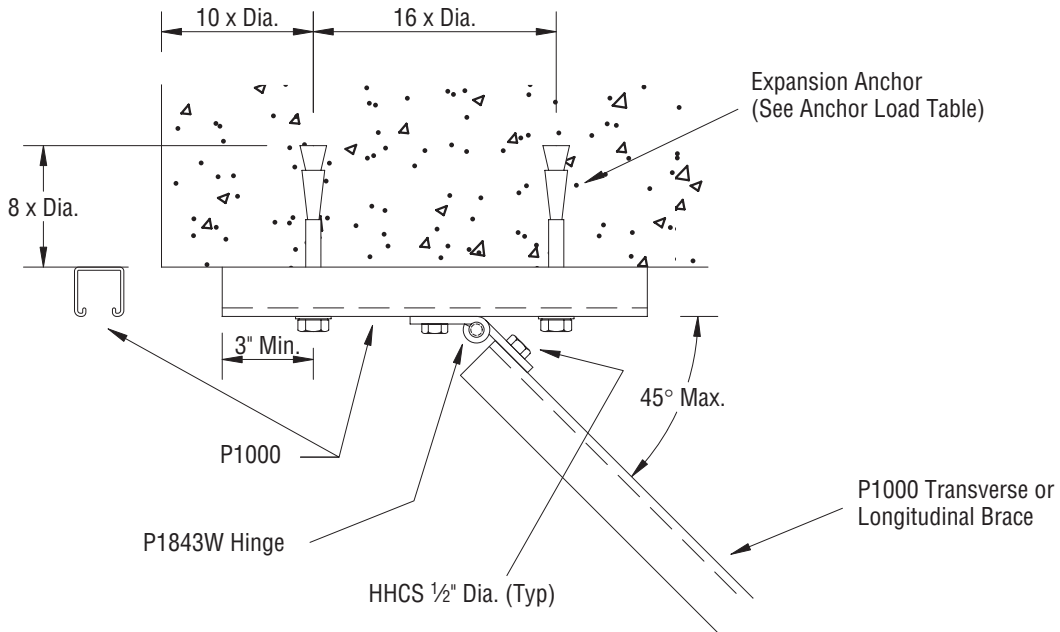
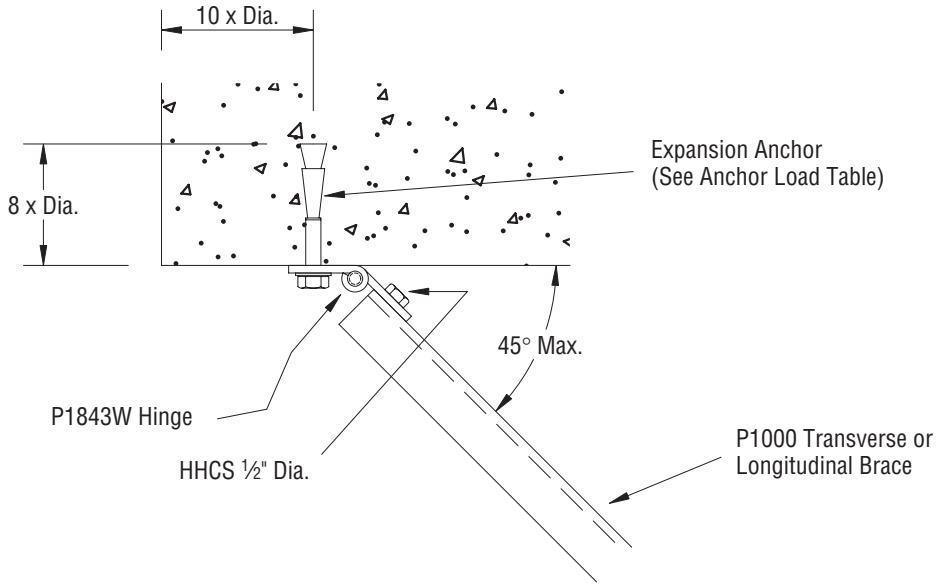

UNISTRUT®

35660 Clinton Street  
Wayne, Michigan 48184  
PH: (800) 521-7730  
FAX: (734) 721-4106

JOSEPH L. LA BRIE  
Structural Engineer  
No. SE 3566  
55 E. Walnut St. Suite 277  
Arcadia, CA 91006

DATE:

04/25/2003

PAGE

5-5

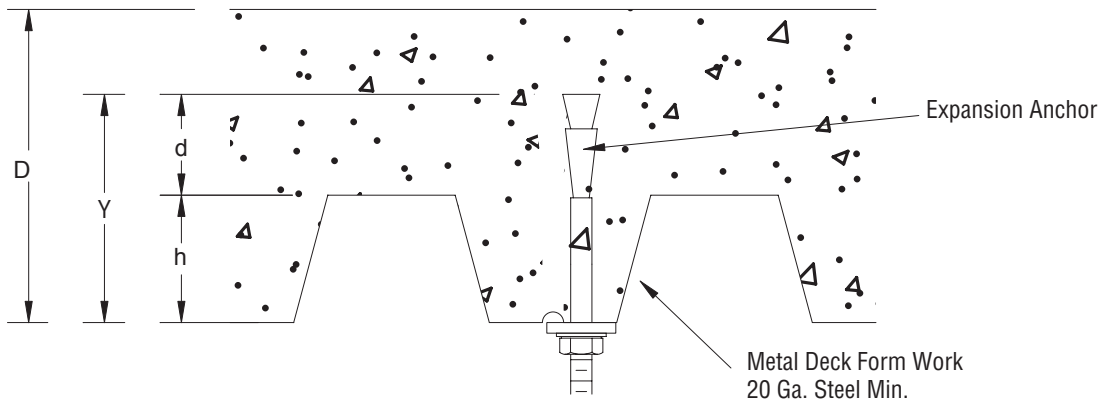
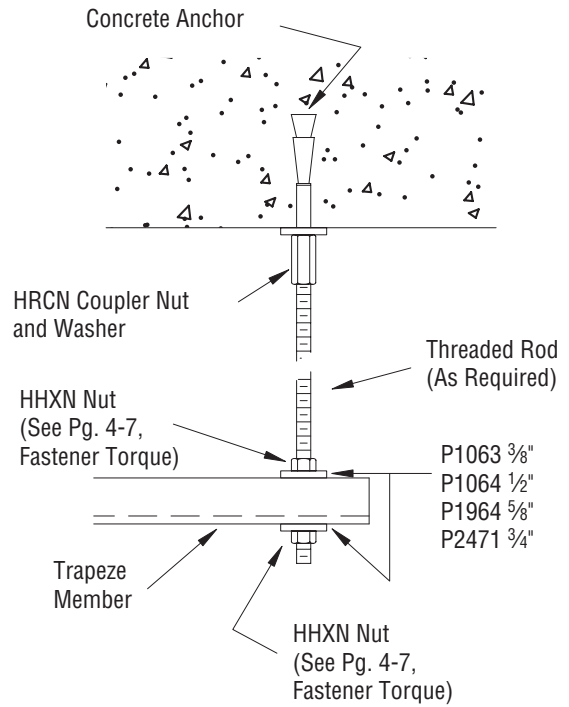
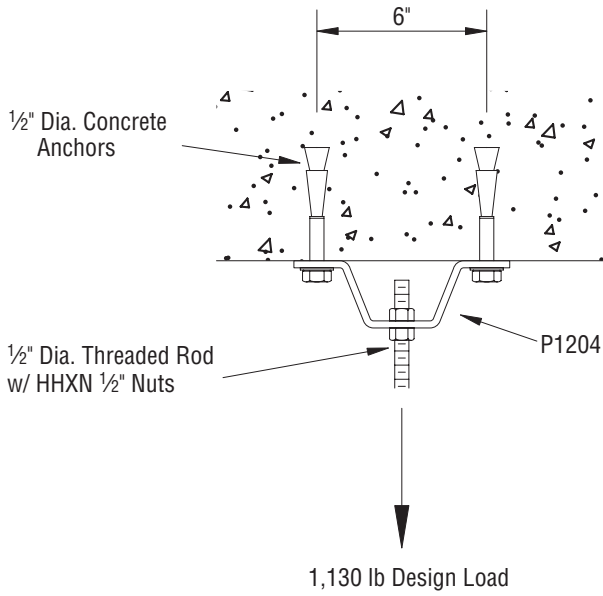

$d \geq$  Larger of 1 1/2" OR (Required embedment for the proposed anchor\* -  $h/3$ )  $\leq$  (Depth of Slab (D) - 1")

Y = 8 x Anchor Diameter for 100% of Design Load Values for Anchor

If less than 8x then use 50% of Design Load Values for Anchor

\*See Anchor Load Table.



**UNISTRUT®**

35660 Clinton Street  
Wayne, Michigan 48184  
PH: (800) 521-7730  
FAX: (734) 721-4106

JOSEPH L. LA BRIE  
Structural Engineer  
No. SE 3566  
55 E. Walnut St. Suite 277  
Arcadia, CA 91006

DATE:

04/25/2003

PAGE

5-6

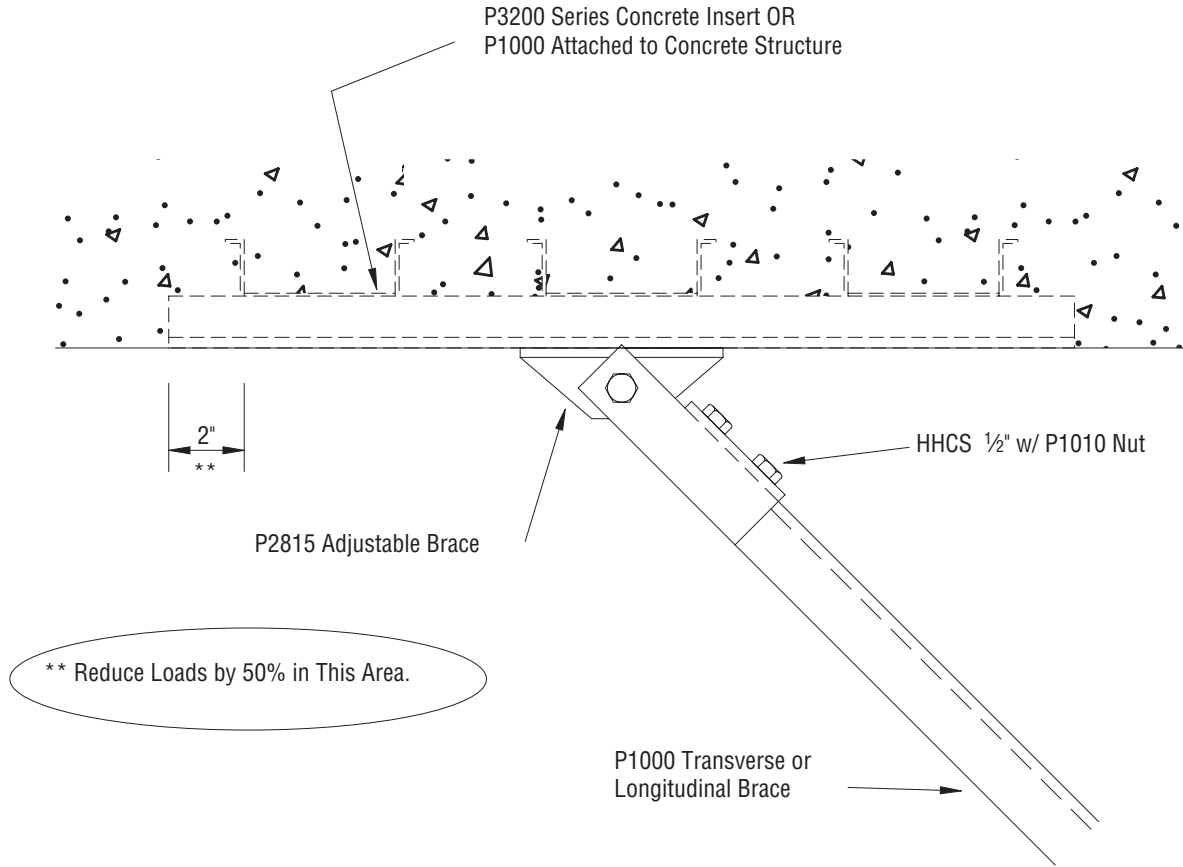

\*\* Reduce Loads by 50% in This Area.

**APPROVED**  
**Fixed Equipment Anchorage**  
 Office of Statewide Health Planning and Development

**OPA-0120 Apr 25, 2003**

\*\*\*\* Valid for 3 Years Maximum \*\*\*\*



Bill Stashin (916) 324-9106



**UNISTRUT®**  
 35660 Clinton Street  
 Wayne, Michigan 48184  
 PH: (800) 521-7730  
 FAX: (734) 721-4106

JOSEPH L. LA BRIE  
 Structural Engineer  
 No. SE 3566  
 55 E. Walnut St. Suite 277  
 Arcadia, CA 91006

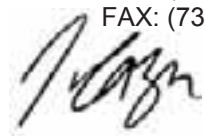

DATE: **04/25/2003**

PAGE  
**5-7**

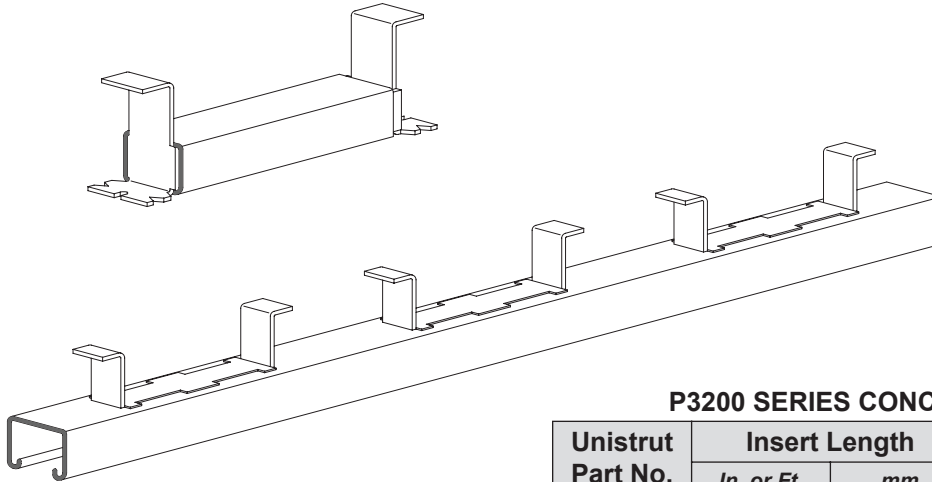

### P3200 SERIES CONCRETE INSERTS

Unistrut Part No.	Insert Length		Design Load	
	In. or Ft.	mm	Lbs.	kN
P3249	3"	76	500	2
P3250	4"	102	800	3.5
P3251	6"	152	1,000	4.4
P3252	8"	203	1,200	5.3
P3253	12"	302	2,000 lbs. (8.9 kN) Load Allowed in Each Foot of Length. Reduce to 1,000 lbs (4.4kN) Load within 2" of Each End.	
P3254	16"	406		
P3255	20"	508		
P3256	24"	610		
P3257	32"	813		
P3257A	36"	914		
P3258	40"	1,016		
P3259	4'	1,224		
P3260	5'	1,524		
P3261	6'	1,824		
P3262	7'	2,136		
P3263	8'	2,436		
P3264	9'	2,748		
P3265	10'	3,048		
P3266	12'	3,660		
P3267	14'	4,272		
P3268	16'	4,872		
P3269	18'	5,484		
P3270	20'	6,096		

**NOTE:**

Recommended loading on inserts in 3,000 psi concrete. Sufficient concrete must surround inserts to conform to design shear stress. The distance between the insert centerline and the concrete edge must be a minimum of 3".

Values in the Table are based on a safety factor of 3 to 1. For installation in Hospitals, use 65% of tabulated values. When installing underside of slab, use 50% of tabulated values.



### UNISTRUT®

35660 Clinton Street  
Wayne, Michigan 48184  
PH: (800) 521-7730  
FAX: (734) 721-4106

JOSEPH L. LA BRIE  
Structural Engineer  
No. SE 3566  
55 E. Walnut St. Suite 277  
Arcadia, CA 91006

DATE:

04/25/2003

PAGE

5-8

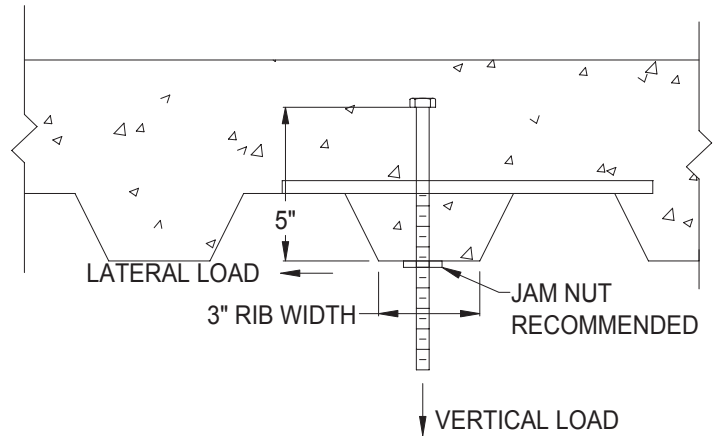
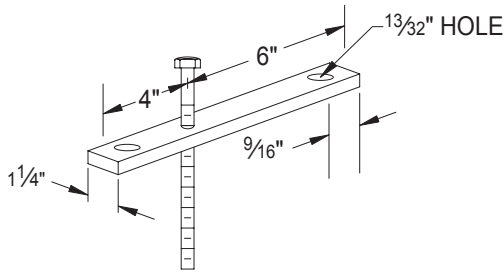

**P3700 SERIES CONCRETE INSERT**

UNISTRUT Part No.	Rod Diameter <i>(in)</i>	Design Load			
		Tension		Shear	
		<i>(lbs)</i>	<i>(KN)</i>	<i>(lbs)</i>	<i>(KN)</i>
P3700-37	3/8	850	3,781	600	2,669
P3700-50	1/2	1380	6,138	1000	4,448
P3700-62	5/8	1920	8,540	1760	7,828

Note: 1) Allowable loads have been determined by the manufacturer's testing, analysis, and technical specification.  
2) Values are based on a safety factor of 5.



**UNISTRUT®**

35660 Clinton Street  
Wayne, Michigan 48184  
PH: (800) 521-7730  
FAX: (734) 721-4106

JOSEPH L. LA BRIE  
Structural Engineer  
No. SE 3566  
55 E. Walnut St. Suite 277  
Arcadia, CA 91006

DATE:

04/25/2003

PAGE

5-9



### EXPANSION BOLT NOTES

1. Drilled-in anchors shall be ITW Ramset/Red Head Self-Drilling per I.C.B.O. Report No. 1372, March 1, 2000. Other anchors may be substituted providing they have an I.C.B.O rating equal or greater than the values tabulated below. User should be using load stated in (most recent) I.C.B.O. report. Tabulated loads are for anchors installed in the tension (underside) zone of structural members (beams and slabs) and have been reduced per OSHPD guidelines.
2. Minimum concrete  $f'_c = 3,000$  psi, normal weight.
3. Minimum embedment of all bolts shall be as shown below.
4. When installing drilled-in anchors and or powder driven pins in existing non-stressed concrete, use care and caution to avoid cutting or damaging the existing reinforcement bars. Maintain a minimum clearance of one inch between the reinforcement and the drilled in anchor and or pin.
5. All concrete expansion type anchor bolts (loaded in either pullout or shear) shall have 50 percent of the bolts (alternate bolts in any group arrangement) proof tested in tension to twice the allowable tension load. If any anchor fails testing, test all anchors of the same category installed by the same trade not previously tested until twenty (20) consecutive pass, then resume the initial testing frequency.
6. Use 50% of allowable tension when anchors are installed in the tension zone of the concrete. Project Engineer to verify.
7. Bolt spacing and installation shall conform to the requirements of the I.C.B.O. report.



$$\text{Combined Interaction (i)} = \left( \frac{\text{Applied Service Tension Load}}{\text{Allowable Service Tension Load}} \right)^{5/3} + \left( \frac{\text{Applied Service Shear Load}}{\text{Allowable Service Shear Load}} \right)^{5/3} \leq 1$$

<div style="border: 1px solid black; padding: 5px;"> <p style="text-align: center;"><b>A P P R O V E D</b>  <b>Fixed Equipment Anchorage</b>  <small>Office of Statewide Health Planning and Development</small></p> <p style="text-align: center;"><b>OPA-0120 Apr 25, 2003</b></p> <p style="text-align: center;"><small>**** Valid for 3 Years Maximum ****</small></p> <div style="display: flex; justify-content: space-between; align-items: center;"> <div style="text-align: right;">   <small>Bill Staehlin (916) 324-9106</small> </div> </div> </div>	<div style="display: flex; justify-content: space-between; align-items: center;"> <div style="text-align: right;"> <p><b>UNISTRUT®</b>              35660 Clinton Street              Wayne, Michigan 48184              PH: (800) 521-7730              FAX: (734) 721-4106</p> </div> </div> <div style="margin-top: 10px;"> <p>JOSEPH L. LA BRIE              Structural Engineer              No. SE 3566              55 E. Walnut St. Suite 277              Arcadia, CA 91006</p> </div>		
DATE:	<b>04/25/2003</b>	PAGE	<b>6-1</b>

**Wedge Anchor Test Loads**

Normal Weight Concrete					
Anchor Diameter (in)	Minimum Embedment (in)	Allowable Tension (lbs)	Allowable Shear (lbs)	Torque Test Tension (ft-lbs)	Direct Tension (lbs)
1/4	2 1/8	556	0	8	800
3/8	3	942	814	25	1,100
1/2	4 1/8	1,430	1,448	50	2,000
5/8	5 1/8	2,150	2,150	80	2,300
3/4	6 5/8	2,868	4,406	150	3,700

Anchor Diameter (in)	Minimum Embedment (in)	Lightweight Concrete		LW Conc. over Mtl. Deck		Torque Test Tension (ft-lbs)	Direct Tension (lbs)
		Allowable Tension (lbs)	Allowable Shear (lbs)	Allowable Tension (lbs)	Allowable Shear (lbs)		
3/8	3	588	848	568	800	25	1,100
1/2	4	0	1,384	960	1,288	50	2,000
5/8	5	1,192	1,856	1,316	1,828	80	2,300
3/4	n/a	n/a	n/a	n/a	n/a	150	3,700

<p style="text-align: center;"><b>A P P R O V E D</b>  <b>Fixed Equipment Anchorage</b>                  Office of Statewide Health Planning and Development</p> <p style="text-align: center;"><b>OPA-0120 Apr 25, 2003</b></p> <p style="text-align: center;">**** Valid for 3 Years Maximum ****</p>  <p style="text-align: center;"><i>Bill Staehlin</i>                  Bill Staehlin (916) 324-9106</p>	 <p style="text-align: right;"><b>UNISTRUT®</b>                  35660 Clinton Street                  Wayne, Michigan 48184                  PH: (800) 521-7730                  FAX: (734) 721-4106</p> <p>JOSEPH L. LA BRIE                  Structural Engineer                  No. SE 3566                  55 E. Walnut St. Suite 277                  Arcadia, CA 91006</p> 
DATE: <b>04/25/2003</b>	PAGE <b>6-2</b>



### EXPANSION BOLT TEST SPECIFICATIONS

1. Anchor diameter refers to the thread size of the WEDGE category.
2. Apply proof test loads to WEDGE anchors without removing the nut if possible. If not, remove nut & install a threaded coupler to the same tightness of the original nut using a torque wrench and apply load.
3. Reaction loads from test fixtures may be applied close to the anchor being tested, provided the anchor is not restrained from withdrawing by the fixture(s).
4. Test equipment is to be calibrated by an approved testing laboratory in accordance with standard recognized procedures.
5. The following criteria apply for the acceptance of installed anchors:

#### HYDRAULIC RAM METHOD:

The anchor should have no observable movement at the applicable test load. For wedge and sleeve type anchors, a practical way to determine observable movement is that the washer under the nut becomes loose.

#### TORQUE WRENCH METHOD:

The applicable test torque must be reached within the following limits:

Wedge: One-half (1/2) turn of the nut.

6. Testing should occur 24 hours minimum after installation of the subject anchors.
7. All tests shall be performed in the presence of the Inspector of Record.
8. If manufacturer's installation torque is less than the test torque, use the installation torque in lieu of the tabulated values.

<p><b>A P P R O V E D</b> <b>Fixed Equipment Anchorage</b> Office of Statewide Health Planning and Development</p> <p><b>OPA-0120 Apr 25, 2003</b></p> <p>**** Valid for 3 Years Maximum ****</p>  <p><i>Bill Staehlin</i> Bill Staehlin (916) 324-9106</p>	 <p><b>UNISTRUT®</b> 35660 Clinton Street Wayne, Michigan 48184 PH: (800) 521-7730 FAX: (734) 721-4106</p> <p>JOSEPH L. LA BRIE Structural Engineer No. SE 3566 55 E. Walnut St. Suite 277 Arcadia, CA 91006</p> 
DATE: 04/25/2003	PAGE <b>6-3</b>

**Problem:**

Design a brace for a single pipe hanger with 8" diameter pipe and hangers spaced at maximum distance (see figure below).

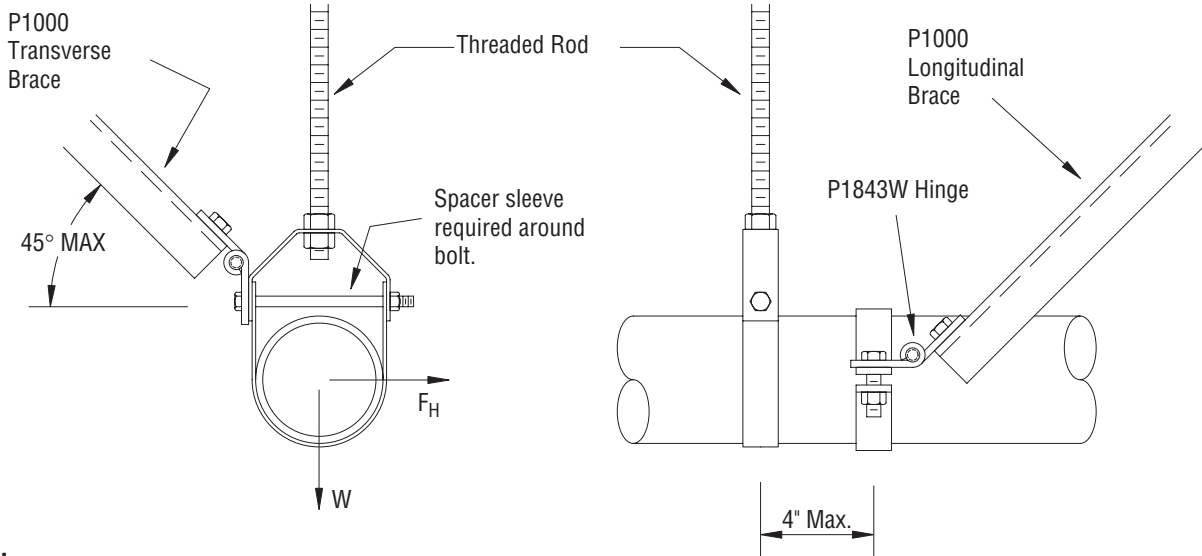

**Solution:**

Step 1 Select Clevis hanger for 8" diameter pipe (Page 3-7).

Step 2 (Page 2-3, Pipe Data Table) Determine the maximum hanger spacing (S):

**S = 10 ft (On Center)**

the unit weight of the 8" pipe full of water (W):

**W = 50.29 lbs/ft**

Step 3 Calculate horizontal seismic force ( $F_H$ ):

**If pipe placed above ceiling of 2<sup>nd</sup> floor (20 ft) of a 4 story (40 ft) building and is within the seismic limits defined in page 1-1, then  $C_s$  can be taken from Seismic Design Coefficient Graph, Page 1-1:**

$$\left. \begin{aligned} h_x &= 20' \\ h_r &= 40' \\ h_x/h_r &= 0.5 \end{aligned} \right\}$$

$C_s = 0.83$   
(within  $0.693 \leq C_s \leq 3.96$ )

$F_H = C_s(W) = 0.83(50.29 \text{ lbs}) = 41.7 \text{ lbs/ft}$

$F_h = F_H/1.4 = 29.8 \text{ lbs/ft}$

(converts to working stress loads)

<p style="text-align: center;"><b>APPROVED</b> <b>Fixed Equipment Anchorage</b> Office of Statewide Health Planning and Development</p> <p style="text-align: center;"><b>OPA-0120 Apr 25, 2003</b></p> <p style="text-align: center;">**** Valid for 3 Years Maximum ****</p> <p style="text-align: center;"><i>Bill Staehlin</i> Bill Staehlin (916) 324-9106</p>	<p style="text-align: right;"><b>UNISTRUT®</b> 35660 Clinton Street Wayne, Michigan 48184 PH: (800) 521-7730 FAX: (734) 721-4106</p> <p style="text-align: center;"><i>Joseph L. LaBrie</i></p> <p>JOSEPH L. LA BRIE Structural Engineer No. SE 3566 55 E. Walnut St. Suite 277 Arcadia, CA 91006</p>
<p>DATE: <b>04/25/2003</b></p>	<p>PAGE <b>7-1</b></p>



Step 4 Actual brace force (maximum at 45°) at every other hanger,

$$F_{b \text{ Actual}} = 1.414 F_h = 1.414(29.8 \text{ lbs/ft} \times 24 \text{ ft}) = 1011 \text{ lbs}$$

Step 5 Select rigid brace P1000.

Check brace against allowable design load:

From Page 4-6 (Brace Design Table), a Brace Span of 84" has a capacity of 1,850 lbs and is greater than  $F_{b \text{ Actual}}$ . **Therefore okay.**

Check slip along channel:

From Page 4-5 (Design Load Table) The maximum slip for a single bolt fitting P1843W is 1500 lbs ( $>F_{b \text{ Actual}}$ ). **Therefore okay.**

Can use any brace length less than 84" to allow slip to be the limiting allowable load.

**Therefore  $F_{b \text{ Allowable}} = 1500 \text{ lbs.}$**

Determine if longitudinal braces are required:

$$\begin{aligned} \text{Brace Spacing} &= F_{b \text{ Allowable}} / (1.414 \times F_h \times \text{hanger spacing}) \\ &= 1500 \text{ lbs} / (1.414 \times 29.8 \text{ lbs/ft} \times 10 \text{ ft}) \\ &= 3 \text{ Bays} \end{aligned}$$

**Therefore, use hangers 10 ft on center, Transverse Brace on every other hanger, and Longitudinal Brace on every Transverse Brace.**

Step 6 (Page 3-11, Capacity of Threaded Rod Table) Maximum Allowable Load (1/2" rod) = 1500 lbs,

$$\text{Actual Seismic Load } (T_{\text{max}}) = W + (F_h \times 24 \text{ ft}) = 604 \text{ lbs} + (29.8 \text{ lbs/ft} \times 24 \text{ ft}) = 1319 \text{ lbs}$$

**Therefore okay.**

Compression is not considered.

Step 7 Verify pipe clamp capacity.

$$\text{Longitudinal Force} = F_h \times \text{brace spacing} = 29.8 \text{ lbs/ft} \times 48 \text{ ft} = 1431 \text{ lbs}$$

From Page 3-6, an 8" pipe has a longitudinal capacity = 500 lbs

Since the 8" pipe longitudinal capacity is less than the actual longitudinal force, adjust longitudinal brace space:

$$\text{Longitudinal Force} = 29.8 \text{ lbs/ft} \times 12 \text{ ft} = 358 \text{ lbs}$$

**Therefore, adjust Longitudinal Brace spacing to every hanger (12 ft on center).**

<p><b>APPROVED</b> Fixed Equipment Anchorage Office of Statewide Health Planning and Development <b>OPA-0120 Apr 25, 2003</b> **** Valid for 3 Years Maximum **** Bill Staehlin (916) 324-9106</p>	<p><b>UNISTRUT®</b> 35660 Clinton Street Wayne, Michigan 48184 PH: (800) 521-7730 FAX: (734) 721-4106</p> <p>JOSEPH L. LA BRIE Structural Engineer No. SE 3566 55 E. Walnut St. Suite 277 Arcadia, CA 91006</p>
	<p>DATE: <b>04/25/2003</b></p>

Step 8 Select concrete anchors for,

**Vertical Supports** – Actual Maximum Tension Load:

$$W \times \text{hanger spacing} = 50.29 \text{ lbs/ft} \times 12 \text{ ft} = 603.5 \text{ lbs.}$$

(Page 6-1) Select a 1/2" diameter 2 1/4" Embedment Anchor:

Maximum Allowable Tension = 1220 lbs. **Therefore okay.**

**Braces (45°)** – Actual Brace Loads:

$$\text{Maximum Shear Load} = 29.8 \text{ lbs/ft} \times 12 \text{ ft} = 358 \text{ lbs for a } 45^\circ \text{ brace}$$

$$\text{Maximum Tension Load} = (1.414) 358 \text{ lbs} = 506 \text{ lbs for a } 45^\circ \text{ brace}$$



(Page 6-1) Select a 1/2" diameter 2 1/4" Embedment Anchor:

Allowable Shear = 952 lbs.

Maximum Allowable Tension = 1220 lbs

$$i = \left( \frac{358}{952} \right)^{5/3} + \left( \frac{506}{1220} \right)^{5/3} = 0.43 \leq 1.0, \text{ Therefore okay.}$$

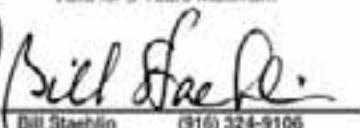
**For Shallow Anchors,  $F_{h(SA)} = 2F_h$ . Therefore, double the seismic load ( $F_h$ ) and repeat Steps 4 through 8.**

<p style="text-align: center;"><b>A P P R O V E D</b>  <b>Fixed Equipment Anchorage</b>                  Office of Statewide Health Planning and Development</p> <p style="text-align: center;"><b>OPA-0120 Apr 25, 2003</b></p> <p style="text-align: center;">**** Valid for 3 Years Maximum ****</p>  <p style="text-align: center;">Bill Staehlin (916) 324-9106</p>	 <p style="text-align: right;"><b>UNISTRUT®</b>                  35660 Clinton Street                  Wayne, Michigan 48184                  PH: (800) 521-7730                  FAX: (734) 721-4106</p>  <p>JOSEPH L. LA BRIE                  Structural Engineer                  No. SE 3566                  55 E. Walnut St. Suite 277                  Arcadia, CA 91006</p>
<p>DATE: <b>04/25/2003</b></p>	<p>PAGE  <b>7-3</b></p>



**Problem:**

Trapeze hanger spanning 24" hung from rods with a seismic brace to be used on left end (see figure below). There is one 2" diameter pipe, one 3" pipe, and one 4" pipe with the load evenly distributed on the trapeze.

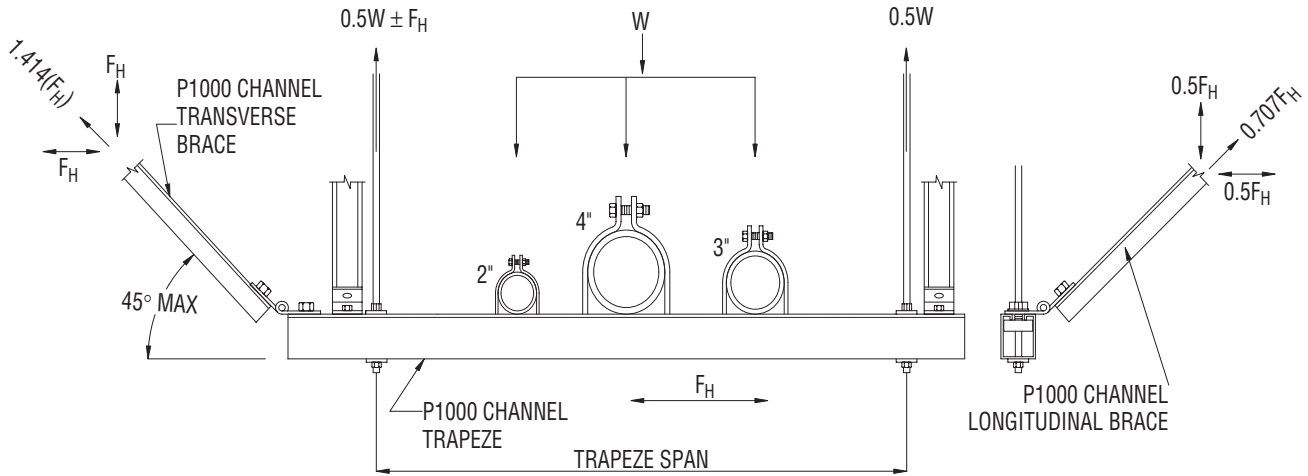

**Solution:**

Step 1 (Page 2-3) Determine the Trapeze Spacing (S) using the smallest pipe diameter.

**For 2" Diameter: S = 10 ft**

Step 2 (Page 2-3) Calculate the weight of the pipes plus contents (W) on each trapeze.

$$W = S \times (p_1 + p_2 + p_3) = 10 \text{ ft} \times (5.11 + 10.78 + 16.31) \text{ lbs/ft} = 322 \text{ lbs}$$

Step 3 Calculate horizontal seismic force ( $F_H$ ) assuming braces on *alternate trapeze supports*

**If pipe placed above ceiling of 2<sup>nd</sup> floor (20 ft) of a 4 story (40 ft) building and is within the seismic limits defined in page 1-1, then  $C_s$  can be taken from Page 1-1, Seismic Design Coefficient Graph:**

$$\left. \begin{array}{l} h_x = 20' \\ h_r = 40' \\ h_x/h_r = 0.5 \end{array} \right\} \quad \begin{array}{l} s = 0.83 \\ \text{(within } 0.693 \leq C_s \leq 3.96) \end{array}$$

$$F_H = C_s(2W) = 0.83 \times 2 \times 322 \text{ lbs} = 535 \text{ lbs} \quad \text{(brace on alternating trapeze)}$$

$$F_h = F_H/1.4 = 535 \text{ lbs}/1.4 = 382 \text{ lbs} \quad \text{(converts to working stress loads)}$$

<p style="text-align: center;"><b>APPROVED</b> Fixed Equipment Anchorage Office of Statewide Health Planning and Development</p> <p style="text-align: center;"><b>OPA-0120 Apr 25, 2003</b></p> <p style="text-align: center;">**** Valid for 3 Years Maximum ****</p> <p style="text-align: center;"><i>Bill Staehlin</i> Bill Staehlin (916) 324-9106</p>	<p style="text-align: right;"><b>UNISTRUT®</b> 35660 Clinton Street Wayne, Michigan 48184 PH: (800) 521-7730 FAX: (734) 721-4106</p> <p style="text-align: center;"><i>Joseph L. LaBrie</i></p> <p>JOSEPH L. LA BRIE Structural Engineer No. SE 3566 55 E. Walnut St. Suite 277 Arcadia, CA 91006</p>
<p>DATE: <b>04/25/2003</b></p>	<p>PAGE <b>7-4</b></p>

Step 4 Actual Brace Force (maximum at 45°):

$$F_{b \text{ Actual}} = 1.414(F_h) = 1.414(382 \text{ lbs}) = 540 \text{ lbs}$$

Step 5 Select fitting P1843W from Page 4-7 & check slip along channel:

From Page 4-5 (Design Load Table), the maximum slip resistance for a single bolt fitting P1843W is 1,500 lbs and is greater than  $F_{b \text{ Actual}}$ . **Therefore O.K.**

Check brace against allowable design load:

From Page 4-6 (Brace Design Table), the maximum brace span that can be used is 120", which yields a capacity of 1,200 lbs and is greater than  $F_{b \text{ Actual}}$ . **Therefore O.K.**

Can use any brace length less than 120".

**The limiting allowable load is the Brace Design Load. Therefore  $F_{b \text{ Allow.}} = 1,200 \text{ lbs.}$**

Determine if **longitudinal** braces are required:

$$\begin{aligned} \text{Brace Spacing (\# of bays)} &= F_{b \text{ Allow.}} / (0.5F_h) \\ &= 1200 \text{ lbs} / (.5 * 382 \text{ lbs}) \\ &\approx 6 \text{ bays} \end{aligned}$$

Determine if **transverse** bracing is required:

$$\begin{aligned} \text{Brace Spacing (\# of bays)} &= F_{b \text{ Allow.}} / (F_h) \\ &= 425 \text{ lbs} / (382 \text{ lbs}) \\ &\approx 3 \text{ bays} \end{aligned}$$

**Therefore provide Transverse Brace at every other hanger and Longitudinal Brace at every other Transverse Brace.**

Step 6 Check compression and tension forces in the rod with brace on alternate hangers.

a.  $T_{\text{max}} = 0.5W + F_h = .5(322) + 382 = 543 \text{ lbs}$

(Page 3-11, Threaded Rod Table) **A 3/8" rod will carry a Seismic Load of 810 lbs, which is greater than  $T_{\text{max}}$ . Therefore is acceptable.**

b.  $C_{\text{max}} = 0.5W - F_h = .5(322) - 382 = -221 \text{ lbs}$

Check buckling due to compression by determining the percentage of full stress capacity:

$$C_{\text{max}} / C_{\text{Allowable}} = 22 / 1810 = 0.27$$

(Page 3-10, Channel Stiffener Table) Since 27% is less than 50%:

**Use P1000T stiffener with P2485 clips spaced 14" on center.**

<p><b>APPROVED</b> Fixed Equipment Anchorage Office of Statewide Health Planning and Development <b>OPA-0120 Apr 25, 2003</b> **** Valid for 3 Years Maximum **** <i>Bill Staehlin</i> Bill Staehlin (916) 324-9106</p>	<p><b>UNISTRUT®</b> 35660 Clinton Street Wayne, Michigan 48184 PH: (800) 521-7730 FAX: (734) 721-4106 JOSEPH L. LA BRIE Structural Engineer No. SE 3566 55 E. Walnut St. Suite 277 Arcadia, CA 91006</p>



Step 7 Select clamps from Pages 3-3 & 3-4.

**Style P1100 series or P2558 series can be used.**

Check P1121 clamp against transverse and longitudinal seismic forces.

(Reference Page 2-3, Pipe Data Table) Use largest pipe – 4" diameter:

Transverse Force = 16.31lbs/ft x 10ft x 0.83/1.4 = 97 lbs

Longitudinal Force = 16.31lbs/ft x 20ft x 0.83/1.4 = 194 lbs

From Page 3-3, *allowable transverse* force is 320 x 1.33 = 425 lbs

Transverse force (97 lbs) is less than allowable (425 lbs), **therefore okay.**

From Page 3-3, *allowable longitudinal* force is 200 x 1.33 = 266 lbs

Longitudinal force (194 lbs) is less than allowable (266 lbs), **therefore okay.**

Step 8 (Page 3-1) Select a trapeze member.

**A P1000 spanning 24" will carry 1690 lbs, which is greater than the calculated W=322 lbs (from Step 2).**

Step 9 Check combined vertical and lateral bending using interaction formula given on Page 2-2 (Using a P1000 with 24" span, get allowable loads from Page 4-4, Beam Load Table):

$$\frac{322}{0.92 \times 1690} + \frac{382}{0.92 \times 2430} \leq 1.33$$

$$0.207 + 0.169 = \mathbf{0.38} \leq \mathbf{1.33} \quad \text{Therefore O.K.}$$

Step 10 Select anchors/connection.

(Pages 5-2 through 5-4) For steel structure attachments, select P1649AS with 3/8" rod.

**Design Load = 650 lbs > T<sub>max</sub>. Therefore okay.**



<p style="text-align: center;"><b>A P P R O V E D</b>  <b>Fixed Equipment Anchorage</b>          Office of Statewide Health Planning and Development</p> <p style="text-align: center;"><b>OPA-0120 Apr 25, 2003</b></p> <p style="text-align: center;">**** Valid for 3 Years Maximum ****</p>  <p style="text-align: center;"><i>Bill Staehlin</i>          Bill Staehlin (916) 324-9106</p>	 <p style="text-align: right;"><b>UNISTRUT®</b>          35660 Clinton Street          Wayne, Michigan 48184          PH: (800) 521-7730          FAX: (734) 721-4106</p> <p>JOSEPH L. LA BRIE          Structural Engineer          No. SE 3566          55 E. Walnut St. Suite 277          Arcadia, CA 91006</p> 
<p>DATE: <b>04/25/2003</b></p>	<p>PAGE  <b>7-6</b></p>

The following defines the design seismic force ( $F_p$ ) as described in the 2000 International Building Code (I.B.C.). The engineer of record shall qualify for the calculation of the seismic force as needed. This sheet provided for **reference only**.

$$F_p = \frac{0.4a_p S_{DS} W_p}{\frac{R_p}{I_p}} \left(1 + 2 \frac{z}{h}\right)$$

- $a_p$  = Component amplification factor:  
(Table 1621.3, 2000 IBC)
- $I_p$  = Component importance factor:  
(Section 1621.1.6, 2000 IBC)
- $h$  = Average roof height of structure relative to the base elevation
- $R_p$  = Component response modification factor:  
(Table 1621.2 or 1621.3, 2000 IBC)
- $S_{DS}$  = Design spectral response acceleration at short period:  
(Section 1615.1.3 or  $S_{DS} \approx 2.5C_a$ , 2000 IBC)
- $z$  = Height in structure at point of attachment of component.

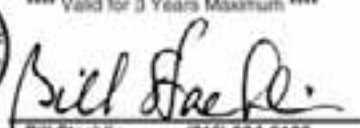
Limits to lateral seismic force:  $0.3 S_{DS} I_p W_p \leq F_p \leq 1.6 S_{DS} I_p W_p$

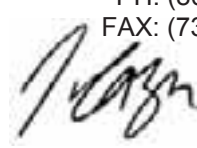
<div style="border: 1px solid black; padding: 10px; text-align: center;"> <p><b>A P P R O V E D</b>  <b>Fixed Equipment Anchorage</b>  <small>Office of Statewide Health Planning and Development</small></p> <p><b>OPA-0120 Apr 25, 2003</b></p> <p>**** Valid for 3 Years Maximum ****</p>   <small>Bill Staehlin (916) 324-9106</small> </div>	<div style="display: flex; justify-content: space-between;">  <div style="text-align: right;"> <p><b>UNISTRUT®</b>                      35660 Clinton Street                      Wayne, Michigan 48184                      PH: (800) 521-7730                      FAX: (734) 721-4106</p> </div> </div> <div style="margin-top: 10px;"> <p>JOSEPH L. LA BRIE                      Structural Engineer                      No. SE 3566                      55 E. Walnut St. Suite 277                      Arcadia, CA 91006</p>  </div>
<p>DATE: <span style="float: right; font-size: 1.2em;">04/25/2003</span></p>	<p>PAGE: <span style="float: right; font-size: 1.2em;">8-1</span></p>



Data for Schedule Steel Pipe

Nominal Size in	Pipe Schedule	Outside Diameter in(mm)	Inside Diameter in(mm)	Pipe Weight lbs/ft (kg/m)	Pipe and Water Weight lbs/ft(kg/m)
1/8	40	0.405 10.3	0.269 6.8	0.24 0.11	0.27 0.12
	80	0.405 10.3	0.215 5.5	0.31 0.14	0.33 0.15
1/4	40	0.54 13.7	0.364 9.23	0.42 0.19	0.47 0.21
	80	0.54 13.7	0.302 7.7	0.53 0.24	0.57 0.26
3/8	40	0.675 17.1	0.493 12.5	0.57 0.26	0.65 0.29
	80	0.675 17.1	0.423 10.7	0.74 0.33	0.80 0.36
1/2	40	1.315 33.4	0.622 15.8	0.85 0.39	0.98 0.45
	80	1.315 33.4	0.546 13.9	1.09 0.49	1.19 0.54
	160	1.315 33.4	0.464 11.8	1.31 0.59	1.38 0.63
3/4	40	1.05 26.7	0.824 20.9	1.13 0.51	1.36 0.62
	80	1.05 26.7	0.742 18.8	1.47 0.67	1.66 0.75
	160	1.05 26.7	0.612 15.5	1.94 0.88	2.07 0.94
1	40	1.315 33.4	1.049 26.6	1.68 0.76	2.05 0.93
	80	1.315 33.4	0.957 24.3	2.17 0.98	2.48 1.13
	160	1.315 33.4	0.815 20.7	2.84 1.29	3.07 1.39
1 1/4	40	1.66 42.2	1.38 35.1	2.27 1.03	2.92 1.32
	80	1.66 42.2	1.278 32.5	2.99 1.36	3.55 1.61
	160	1.66 42.2	1.16 29.5	3.76 1.71	4.22 1.91
1 1/2	40	1.9 48.3	1.61 40.9	2.71 1.23	3.60 1.63
	80	1.9 48.3	1.5 38.1	3.63 1.65	4.39 1.99
	160	1.9 48.3	1.338 34	4.85 2.20	5.46 2.48



**UNISTRUT®**

35660 Clinton Street  
Wayne, Michigan 48184  
PH: (800) 521-7730  
FAX: (734) 721-4106

JOSEPH L. LA BRIE  
Structural Engineer  
No. SE 3566  
55 E. Walnut St. Suite 277  
Arcadia, CA 91006

DATE:

04/25/2003

PAGE

8-2

Data for Schedule Steel Pipe (continued)

Nominal Size in	Pipe Schedule	Outside Diameter in(mm)	Inside Diameter in(mm)	Pipe Weight lbs/ft (kg/m)	Pipe and Water Weight lbs/ft(kg/m)
2	40	2.375 60.3	2.067 52.5	3.65 1.66	5.10 2.32
	80	2.375 60.3	1.939 49.3	5.02 2.28	6.30 2.86
	160	2.375 60.3	1.687 42.8	7.45 3.38	8.42 3.82
2 1/2	40	2.875 73	2.469 62.7	5.79 2.62	7.86 3.57
	80	2.875 73	2.323 59	7.65 3.47	9.49 4.30
	160	2.875 73	2.125 54	10.00 4.54	11.54 5.23
3	40	3.5 88.9	3.068 77.9	7.57 3.43	10.77 4.89
	80	3.5 88.9	2.9 73.7	10.24 4.65	13.11 5.94
	160	3.5 88.9	2.624 66.6	14.31 6.49	16.65 7.55
3 1/2	40	4 101.6	3.548 90.1	9.10 4.13	13.39 6.07
	80	4 101.6	3.364 85.4	12.49 5.67	16.35 7.41
4	40	4.5 114.3	4.026 102.3	10.78 4.89	16.30 7.39
	80	4.5 114.3	3.826 97.2	14.97 6.79	19.95 9.05
	120	4.5 114.3	3.624 92	18.98 8.61	23.45 10.64
	160	4.5 114.3	3.428 87.3	22.48 10.20	26.51 12.02
5	40	5.563 141.3	5.047 128.2	14.60 6.62	23.27 10.56
	80	5.563 141.3	4.813 122.2	20.75 9.41	28.64 12.99
	120	5.563 141.3	4.563 115.9	27.01 12.25	34.09 15.46
	160	5.563 141.3	4.313 109.5	32.92 14.93	39.26 17.81



**UNISTRUT®**

35660 Clinton Street  
Wayne, Michigan 48184  
PH: (800) 521-7730  
FAX: (734) 721-4106

JOSEPH L. LA BRIE  
Structural Engineer  
No. SE 3566  
55 E. Walnut St. Suite 277  
Arcadia, CA 91006

DATE:

04/25/2003

PAGE

8-3



Data for Schedule Steel Pipe (continued)

Nominal Size in	Pipe Schedule	Outside Diameter in(mm)	Inside Diameter in(mm)	Pipe Weight lbs/ft (kg/m)	Pipe and Water Weight lbs/ft(kg/m)
6	40	6.625 168.3	6.065 154.1	18.95 8.60	31.48 14.28
	80	6.625 168.3	5.761 146.3	28.54 12.95	39.84 18.07
	120	6.625 168.3	5.501 139.7	36.35 16.49	46.66 21.16
	160	6.625 168.3	5.187 131.7	45.30 20.55	54.57 24.71
8	20	8.625 219.1	8.125 206.4	22.34 10.13	44.82 20.33
	30	8.625 219.1	8.071 205	24.67 11.19	46.85 21.25
	40	8.625 219.1	7.981 202.7	28.52 12.94	50.21 22.78
	60	8.625 219.1	7.813 198.5	35.60 16.15	56.39 25.58
	80	8.625 219.1	7.625 193.7	43.34 19.66	63.14 28.64
	100	8.625 219.1	7.439 188.9	50.89 23.09	69.73 31.36
	120	8.625 219.1	7.187 182.5	60.65 27.51	78.23 35.49
	140	8.625 219.1	7.001 177.8	67.68 30.7	84.37 38.27
	160	8.625 219.1	6.813 173.1	74.61 33.84	90.42 41.01



**UNISTRUT®**

35660 Clinton Street  
Wayne, Michigan 48184  
PH: (800) 521-7730  
FAX: (734) 721-4106

JOSEPH L. LA BRIE  
Structural Engineer  
No. SE 3566  
55 E. Walnut St. Suite 277  
Arcadia, CA 91006

DATE:

04/25/2003

PAGE



8-4

**Electrical Metallic Tubing (EMT) - Thin Wall**

Tubing Size (Nominal) in	Outside Diameter in (mm)	Inside Diameter in (mm)	Weight of Tubing lbs/ft (kg/m)
3/8	0.577	0.497	0.23
	14.7	12.6	0.34
1/2	0.706	0.626	0.29
	17.9	15.9	0.43
3/4	0.922	0.83	0.44
	23.4	21.1	0.65
1	1.163	1.055	0.64
	29.5	26.8	0.95
1 1/4	1.51	1.388	0.95
	38.4	35.3	1.41
1 1/2	1.74	1.618	1.1
	44.2	41.1	1.64
2	2.197	2.075	1.4
	55.8	52.7	2.08
2 1/2	2.875	2.731	2.3
	73	69.4	3.42
3	3.5	3.356	2.7
	88.9	85.2	4.02
3 1/2	4	3.834	3.4
	101.6	97.4	5.06
4	4.5	4.334	4
	114.3	110.1	5.95

**Intermediate Metallic Conduit (IMC)**

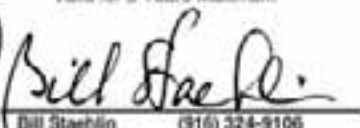
Conduit Size (Nominal) in	Outside Diameter in (mm)	Inside Diameter in (mm)	Weight of Conduit lbs/ft (kg/m)	Weight of Conduit and Conductor lbs/ft (kg/m)
1/2	0.815	0.745	0.6	0.12
	20.7	18.9	0.89	0.18
3/4	1.029	0.954	0.82	1.13
	26.1	24.2	1.22	1.68
1	1.29	1.205	1.16	1.82
	32.8	30.6	1.73	2.71
1 1/4	1.638	1.553	1.5	2.67
	41.6	39.4	2.23	3.97
1 1/2	1.883	1.793	1.82	3.42
	47.8	45.5	2.71	5.09
2	2.36	2.266	2.42	5.04
	59.9	57.6	3.6	7.5
2 1/2	2.857	2.727	4.01	7.75
	72.6	69.3	5.97	11.53
3	3.476	3.346	4.43	10.69
	88.3	85	6.59	15.91
3 1/2	3.971	3.841	5.73	13.46
	100.9	97.6	8.53	20.13
4	4.466	4.336	6.38	16.37
	113.4	110.1	9.49	24.36

<p align="center"><b>A P P R O V E D</b>  <b>Fixed Equipment Anchorage</b>                  Office of Statewide Health Planning and Development</p> <p align="center"><b>OPA-0120 Apr 25, 2003</b></p> <p align="center">**** Valid for 3 Years Maximum ****</p>  <p align="center">Bill Stanbin (916) 324-9106</p>	 <p align="right"><b>UNISTRUT®</b>                  35660 Clinton Street                  Wayne, Michigan 48184                  PH: (800) 521-7730                  FAX: (734) 721-4106</p> <p>JOSEPH L. LA BRIE                  Structural Engineer                  No. SE 3566                  55 E. Walnut St. Suite 277                  Arcadia, CA 91006</p> 
DATE: <b>04/25/2003</b>	PAGE: <b>8-5</b>



### Copper Tube (Type L)

Nom. Tube Size, in	O.D. Tubing in (mm)	O.D. in (mm)	Wall Thick. in (mm)	Wt./Ft lbs (kg)	Wt. Water/Ft. lbs (kg)
1/4	3/8	0.375	0.03	0.126	0.034
	10	9.5	0.8	3.2	0.9
3/8	1/2	0.5	0.035	0.198	0.062
	13	12.7	0.9	5	1.6
1/2	5/8	0.625	0.04	0.285	0.1
	16	15.9	1	7.2	2.5
5/8	3/4	0.75	0.042	0.362	1.51
	19	19.1	1.1	9.2	3.8
3/4	7/8	0.875	0.045	0.455	0.209
	22	22.2	1.1	11.6	5.3
1	1 1/8	1.125	0.05	0.655	3.57
	29	28.6	1.3	16.6	9.1
1 1/4	1 3/8	1.375	0.055	0.884	0.546
	35	34.9	1.4	22.5	13.9
1 1/2	1 5/8	1.625	0.06	1.14	0.9767
	41	41.3	1.5	29	19.5
2	2 1/8	2.125	0.07	1.75	1.341
	54	54	1.8	44.5	34.1
2 1/2	2 5/8	2.625	0.08	2.48	2.064
	67	66.7	2	63	52.4
3	3 1/8	3.125	0.09	3.33	2.949
	79	79.4	2.3	84.6	74.9
3 1/2	3 5/8	3.625	0.1	4.29	3.989
	92	92.1	2.5	109	101.3
4	4 1/8	4.125	0.11	5.38	5.188
	105	104.8	2.8	136.7	131.8
5	5 1/8	5.125	0.125	7.61	8.081
	130	130.2	3.2	193.3	2.05.3
6	6 1/8	6.125	0.14	10.2	11.616
	156	155.6	3.6	259.1	295
8	8 1/8	8.125	0.2	19.29	20.289
	206	206.4	5.1	490	515.3



**UNISTRUT®**

35660 Clinton Street  
Wayne, Michigan 48184  
PH: (800) 521-7730  
FAX: (734) 721-4106

JOSEPH L. LA BRIE  
Structural Engineer  
No. SE 3566  
55 E. Walnut St. Suite 277  
Arcadia, CA 91006

DATE:



04/25/2003

PAGE

8-6

**Copper Tube (Type K)**

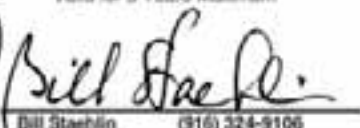
Nom. Tube Size, in	O.D. Tubing in (mm)	O.D. in (mm)	Wall Thick. in (mm)	Wt./Ft lbs (kg)	Wt. Water/Ft. lbs (kg)
1/4	3/8	0.375	0.035	0.145	0.032
	10	9.5	0.89	3.68	0.81
3/8	1/2	0.5	0.005	0.269	0.055
	13	12.7	0.13	6.83	1.4
1/2	5/8	0.625	0.049	0.344	0.094
	16	15.9	1.24	8.74	2.39
5/8	3/4	0.75	0.049	0.418	0.144
	19	19.1	1.24	10.62	3.66
3/4	7/8	0.875	0.065	0.641	0.188
	22	22.2	1.65	16.28	4.78
1	1 1/8	1.125	0.065	0.839	0.337
	29	28.6	1.65	21.31	8.56
1 1/4	1 3/8	1.375	0.065	1.04	0.527
	35	34.9	1.65	26.42	13.39
1 1/2	1 5/8	1.625	0.072	1.36	0.743
	41	41.3	1.83	34.54	18.87
2	2 1/8	2.125	0.083	2.06	1.31
	54	54	2.11	52.32	33.27
2 1/2	2 5/8	2.625	0.095	2.92	2
	67	66.7	2.41	74.17	50.8
3	3 1/8	3.125	0.109	4	2.96
	79	79.4	2.77	101.6	75.18
3 1/2	3 5/8	3.625	0.12	5.12	3.9
	92	92.1	3.05	130.05	99.06
4	4 1/8	4.125	0.134	6.51	5.06
	105	104.8	3.4	165.35	128.52
5	5 1/8	5.125	0.16	9.67	8
	130	130.2	4.06	245.62	203.2
6	6 1/8	6.125	0.192	13.87	11.2
	156	155.6	4.88	352.3	284.48
8	8 1/8	8.125	0.271	25.9	19.5
	206	206.4	6.88	657.86	495.3

<p style="text-align: center;"><b>A P P R O V E D</b>  <b>Fixed Equipment Anchorage</b>                  Office of Statewide Health Planning and Development</p> <p style="text-align: center;"><b>OPA-0120 Apr 25, 2003</b></p> <p style="text-align: center;">**** Valid for 3 Years Maximum ****</p>  <p style="text-align: center;">Bill Staehlin (916) 324-9106</p>	 <p style="text-align: right;"><b>UNISTRUT®</b>                  35660 Clinton Street                  Wayne, Michigan 48184                  PH: (800) 521-7730                  FAX: (734) 721-4106</p> <p>JOSEPH L. LA BRIE                  Structural Engineer                  No. SE 3566                  55 E. Walnut St. Suite 277                  Arcadia, CA 91006</p> 
DATE: <b>04/25/2003</b>	PAGE <b>8-7</b>



### Rigid Steel (Heavy Duty) Conduit

Conduit Size (Nominal) in	I.D. of Conduit in (mm)	O.D. of Conduit in (mm)	O.D. of Coupling in (mm)	Weight of Conduit lbs/ft (kg/m)	Maximum Weight* of Conduit and Conductor Lead Covered lbs/ft (kg/m)	Not Lead Covered lbs/ft (kg/m)
1/2	0.622 15.8	0.84 21.3	1.063 27	0.85 1.26	1.2 1.79	1 1.49
3/4	0.824 20.9	1.05 26.7	1.297 32.9	1.13 1.68	1.8 2.68	1.4 2.08
1	1.049 26.6	1.315 33.4	1.563 39.7	1.68 2.5	2.6 3.87	2.3 3.42
1 1/4	1.38 35.1	1.66 42.2	1.969 50	2.28 3.39	4.3 6.4	3.6 5.36
1 1/2	1.61 40.9	1.9 48.3	2.234 56.7	2.73 4.06	5.9 8.78	4.5 6.7
2	2.067 52.5	2.375 60.3	2.719 69.1	3.68 5.48	8.5 12.65	7.2 10.71
2 1/2	2.469 62.7	2.875 73	3.313 84.2	5.82 8.66	11.5 17.11	10.2 15.18
3	3.068 77.9	3.5 88.9	3.938 100	7.62 11.34	16.5 24.55	14.5 21.58
3 1/2	3.548 90.1	4 101.6	4.438 112.7	9.2 13.69	19 28.28	17.5 26.04
4	4.026 102.3	4.5 114.3	4.938 125.4	10.89 16.21	24.8 36.91	21.5 32
5	5.047 128.2	5.563 141.3	6.294 159.9	14.81 22.04	35.9 53.43	30.8 45.84
6	6.065 154.1	6.625 168.3	7.358 186.9	19.19 28.56	50.7 75.45	43.4 64.59

\* Maximum weight equals weight of rigid conduit plus weight of heaviest conductor combination (from the National Electrical Code Handbook).

Nominal Pipe Size in	Max. Span ft (m)	Nominal Pipe Size in	Max. Span ft (m)
1	7 2.13	8	19 5.79
1 1/2	9 2.74	10	22 6.71
2	10 3.05	12	23 7.01
2 1/2	11 3.35	14	25 7.62
3	12 3.66	16	27 8.23
3 1/2	13 3.96	18	28 8.53
4	14 4.27	20	30 9.14
5	16 4.88	24	32 9.75

The above spacing based on a combined bending and shear stress of 1500 PSI when pipe is filled with water and the pitch of the line is such that a sag of 0.1in. between supports is permissible.



**UNISTRUT®**

35660 Clinton Street  
Wayne, Michigan 48184  
PH: (800) 521-7730  
FAX: (734) 721-4106

JOSEPH L. LA BRIE  
Structural Engineer  
No. SE 3566  
55 E. Walnut St. Suite 277  
Arcadia, CA 91006

DATE:

04/25/2003

PAGE

8-8



**Conduit Supports**

**Supports:** Rigid metal conduit shall be installed as a complete system as provided in Article 300 and shall be securely fastened in place. Conduit shall be firmly fastened within 3 feet (914 mm) of each outlet box, junction box, cabinet, or fitting. Conduit shall be supported at least every 10 feet (3.05m).

*Exception:* If made up with threaded couplings, it shall be permissible to support straight runs of rigid metal conduit in accordance with Table 346-12, provided such supports prevent transmission of stresses to termination where conduit is deflected between supports.

Table 346-12  
Support for Rigid Metal Conduit

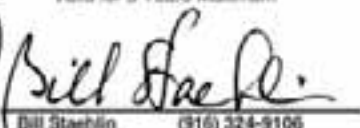
Conduit Size in (mm)	Maximum Distance Between Supports ft (m)
1/2 - 3/4 12.7 - 19.1	10 3.05
1 25.4	12 3.66
1 1/4 - 1 1/2 31.8 - 38.1	14 4.27
2 - 2 1/2 50.8 - 63.5	16 4.88
3 & larger 76.2 - larger	20 6.1

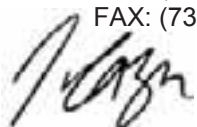
<p style="text-align: center;"><b>A P P R O V E D</b> <b>Fixed Equipment Anchorage</b> Office of Statewide Health Planning and Development</p> <p style="text-align: center;"><b>OPA-0120 Apr 25, 2003</b></p> <p style="text-align: center;">**** Valid for 3 Years Maximum ****</p>  <p style="text-align: center;">Bill Staehlin (916) 324-9106</p>	 <p style="text-align: right;"><b>UNISTRUT®</b> 35660 Clinton Street Wayne, Michigan 48184 PH: (800) 521-7730 FAX: (734) 721-4106</p>  <p>JOSEPH L. LA BRIE Structural Engineer No. SE 3566 55 E. Walnut St. Suite 277 Arcadia, CA 91006</p>
<p>DATE: <b>04/25/2003</b></p>	<p>PAGE <b>8-9</b></p>



### Schedule 40: PVC Plastic Pipe

Pipe Size (Nominal) in	Outside Diameter in (mm)	Inside Diameter in (mm)	Pipe Weight lbs/ft (kg/m)	Pipe and Water Weight lbs/ft (kg/m)
1/4	0.54 13.7	0.354 9	0.081 0.12	0.12 0.18
3/8	0.675 17.1	0.483 12.3	0.109 0.16	0.19 0.28
1/2	0.84 21.3	0.608 15.4	0.161 0.24	0.29 0.43
3/4	1.05 26.7	0.81 20.6	0.214 0.32	0.44 0.65
1	1.315 33.4	1.033 26.2	0.315 0.47	0.68 1.01
1 1/4	1.66 42.2	1.364 34.6	0.426 0.63	1.06 1.58
1 1/2	1.9 48.3	1.592 40.4	0.509 0.76	1.37 2.04
2	2.375 60.3	2.049 52	0.682 1.01	2.11 3.14
2 1/2	2.875 73	2.445 62.1	1.076 1.6	3.11 4.63
3	3.5 88.9	3.042 77.3	1.409 2.1	4.55 6.77
4	4.5 114.3	3.998 101.5	2.006 2.99	7.44 11.07
6	6.625 168.3	6.031 153.2	3.535 5.26	15.9 23.66
8	8.625 219.1	7.943 201.8	5.305 7.89	26.75 39.81
10	10.75 273.1	9.976 253.4	7.532 11.21	41.35 61.54



**UNISTRUT®**

35660 Clinton Street  
Wayne, Michigan 48184  
PH: (800) 521-7730  
FAX: (734) 721-4106

JOSEPH L. LA BRIE  
Structural Engineer  
No. SE 3566  
55 E. Walnut St. Suite 277  
Arcadia, CA 91006

DATE:

04/25/2003

PAGE

8-10

# UNISTRUT®

The ORIGINAL  
Strut System

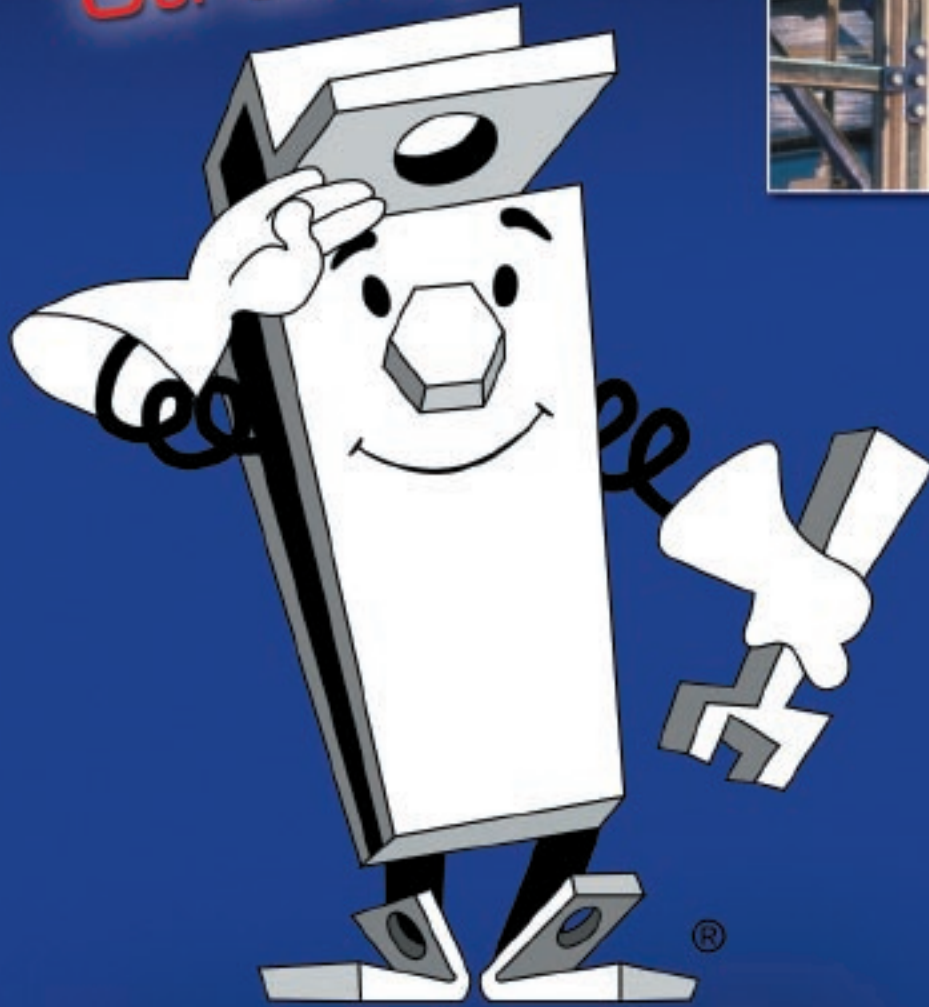

Check my website  
for ideas for your  
next project!  
[www.unistrut.com](http://www.unistrut.com)



# UNISTRUT<sup>®</sup>

35660 Clinton Street • Wayne, Michigan 48184

Tel: (800) 521-7730 • Fax: (734) 721-4106

[www.unistrutseismic.com](http://www.unistrutseismic.com)

**tyco** | Electrical &  
Metal Products