

GENERAL NOTES

1. THIS UNISTRUT SUPPORT SYSTEM IS DESIGNED TO SUPPORT A MAXIMUM UNIFORM LOAD OF \_\_\_ PS\*
2. AREA DIRECTLY ABOVE THE VERTICAL SUPPORT TO BE FREE AND CLEAR OF ALL OBSTRUCTIONS.
3. EXISTING STRUCTURE TO BE CHECKED BY OTHERS.
4. ALL CHANNEL & FITTINGS TO HAVE STANDARD UNISTRUT "PERMA-GREEN" FINISH AND ALL HARDWARE TO BE ELECTRO-GALVANIZED.

\* DESIGN LOAD VARIES BASED ON MAXIMUM SPANS - PLEASE CONTACT YOUR LOCAL UNISTRUT CONSTRUCTION OFFICE FOR SPECIFIC LOADING DESIGN.

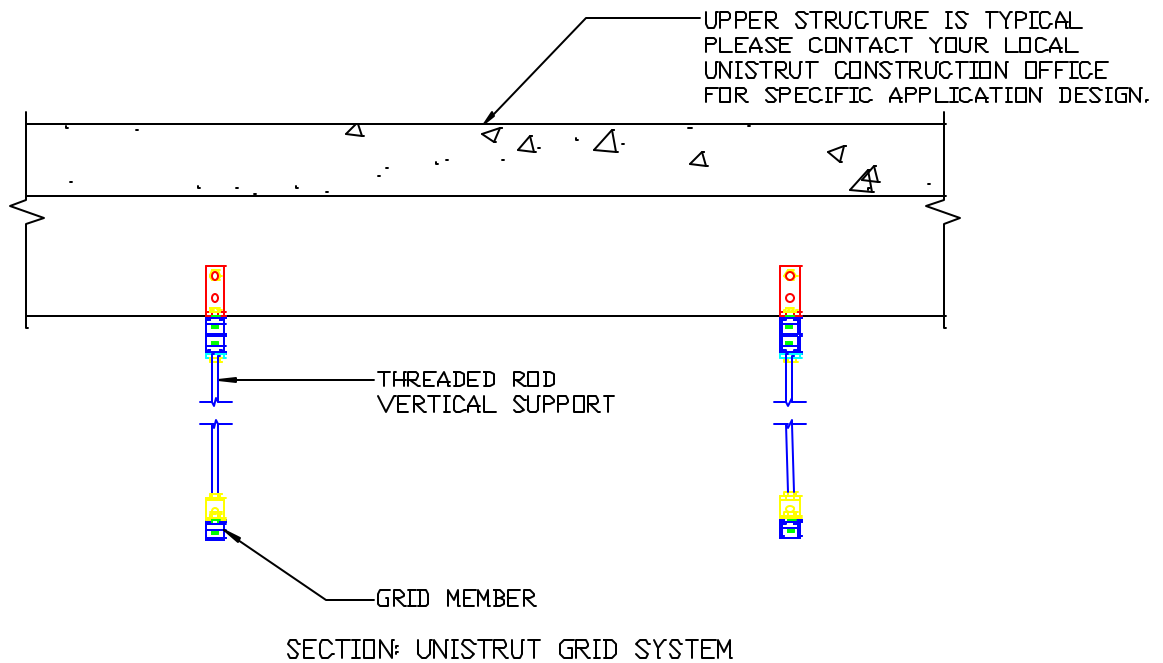
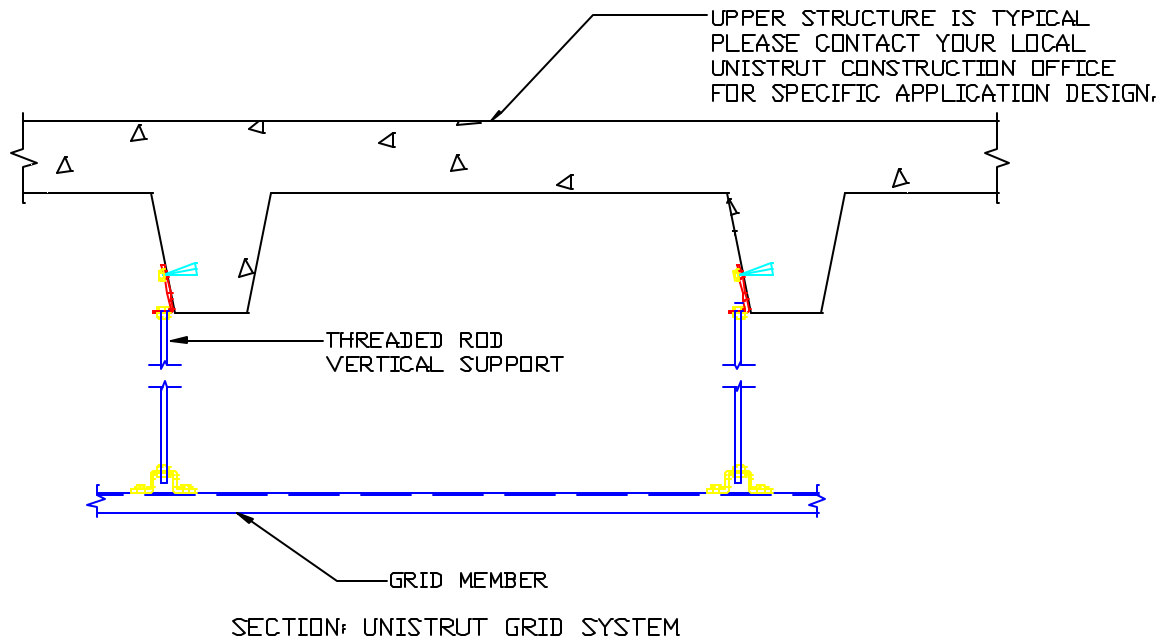

**UNISTRUT CORPORATION**  
DESIGN & INSTALLATION  
CONSTRUCTION DIVISION  
PHONE: 1-800-468-9510

UNISTRUT 1 LEVEL 1 WAY  
P1000 CEILING GRID

BY SB

DATE 12/05/03

TG-1L1W-00-CB

SHEET  
1 OF 1

GENERAL NOTES

1. THIS UNISTRUT SUPPORT SYSTEM IS DESIGNED TO SUPPORT A MAXIMUM UNIFORM LOAD OF \_\_\_ PS\*
2. AREA DIRECTLY ABOVE THE VERTICAL SUPPORT TO BE FREE AND CLEAR OF ALL OBSTRUCTIONS.
3. EXISTING STRUCTURE TO BE CHECKED BY OTHERS.
4. ALL CHANNEL & FITTINGS TO HAVE STANDARD UNISTRUT "PERMA-GREEN" FINISH AND ALL HARDWARE TO BE ELECTRO-GALVANIZED.

\* DESIGN LOAD VARIES BASED ON MAXIMUM SPANS - PLEASE CONTACT YOUR LOCAL UNISTRUT CONSTRUCTION OFFICE FOR SPECIFIC LOADING DESIGN.

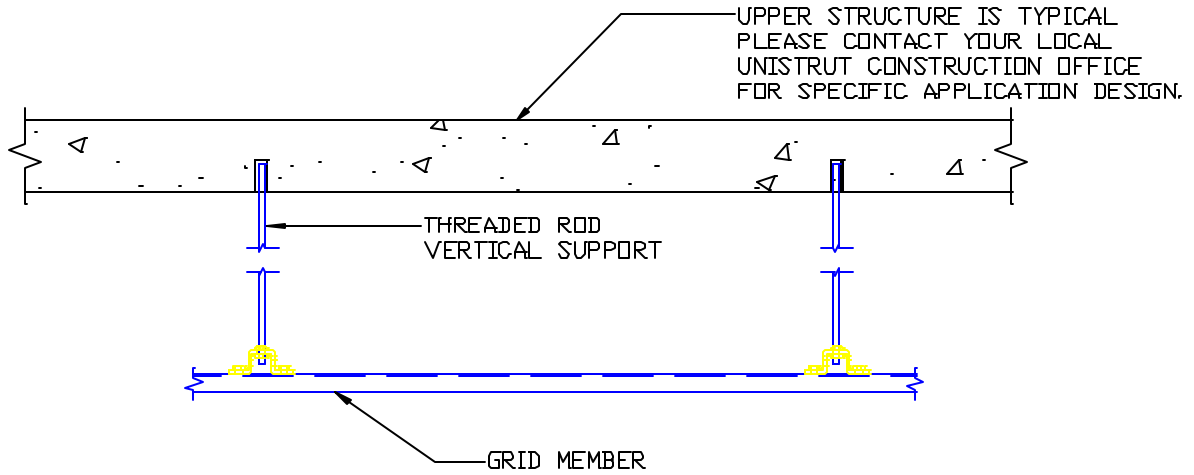

SECTION: UNISTRUT GRID SYSTEM

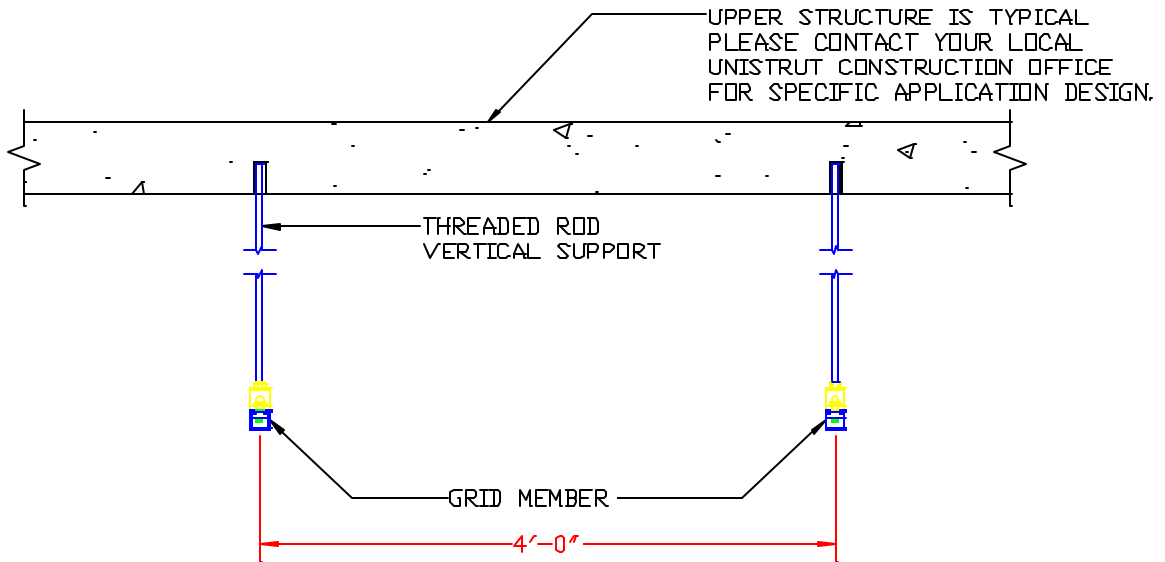

SECTION: UNISTRUT GRID SYSTEM

**UNISTRUT CORPORATION**  
 DESIGN & INSTALLATION  
 CONSTRUCTION DIVISION  
 PHONE: 1-800-468-9510

UNISTRUT 1 LEVEL 1 WAY  
 P1000 CEILING GRID

BY SB

DATE 12/05/03

TG-1L1W-00-CS

SHEET  
 1 OF 1

GENERAL NOTES

1. THIS UNISTRUT SUPPORT SYSTEM IS DESIGNED TO SUPPORT A MAXIMUM UNIFORM LOAD OF \_\_\_ PSF\*
2. AREA DIRECTLY ABOVE THE VERTICAL SUPPORT TO BE FREE AND CLEAR OF ALL OBSTRUCTIONS.
3. EXISTING STRUCTURE TO BE CHECKED BY OTHERS.
4. ALL CHANNEL & FITTINGS TO HAVE STANDARD UNISTRUT "PERMA-GREEN" FINISH AND ALL HARDWARE TO BE ELECTRO-GALVANIZED.

\* DESIGN LOAD VARIES BASED ON MAXIMUM SPANS - PLEASE CONTACT YOUR LOCAL UNISTRUT OFFICE FOR SPECIFIC LOADING DESIGN.

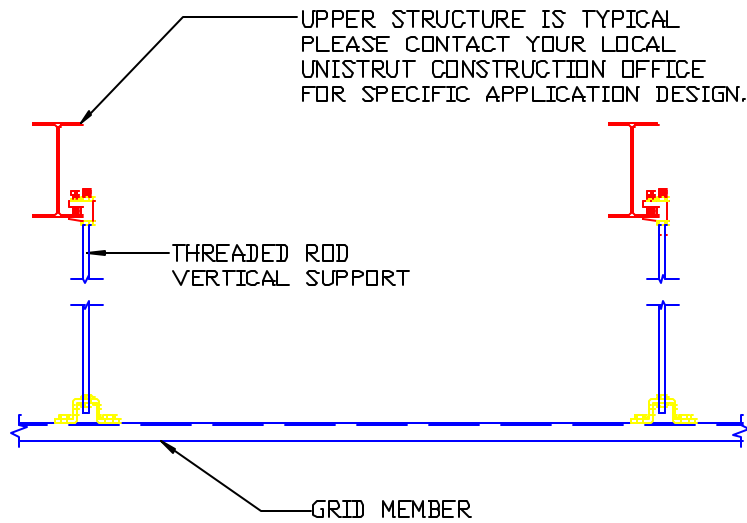

SECTION: UNISTRUT GRID SYSTEM

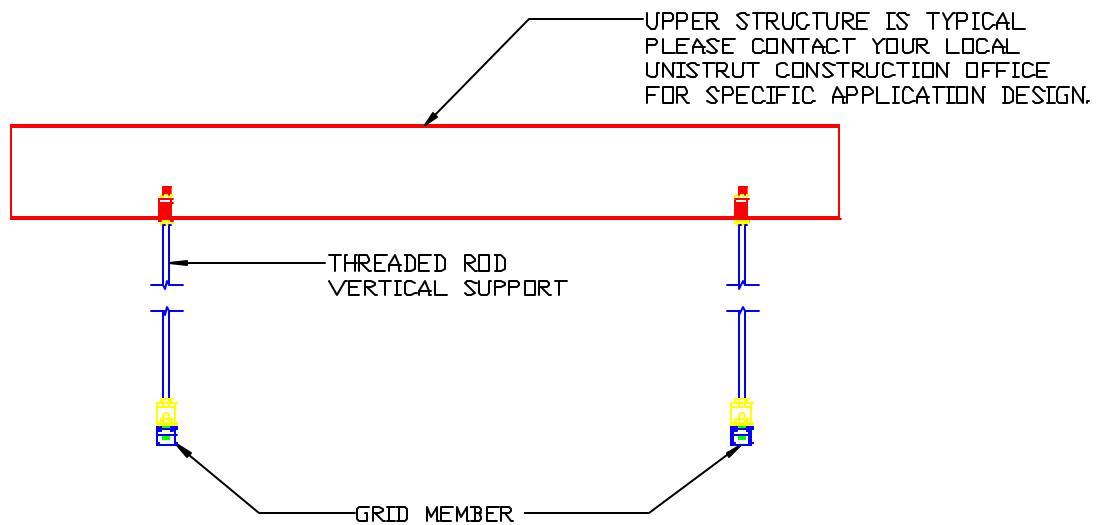

SECTION: UNISTRUT GRID SYSTEM

**UNISTRUT CORPORATION**  
 DESIGN & INSTALLATION  
 CONSTRUCTION DIVISION  
 PHONE: 1-800-468-9510

UNISTRUT 1 LEVEL 1 WAY  
 P1000 CEILING GRID

BY SB

DATE 12/05/03

TG-1L1W-00-SB

SHEET  
 1 OF 1

GENERAL NOTES

1. THIS UNISTRUT SUPPORT SYSTEM IS DESIGNED TO SUPPORT A MAXIMUM UNIFORM LOAD OF \_\_\_ PSI\*
2. AREA DIRECTLY ABOVE THE VERTICAL SUPPORT TO BE FREE AND CLEAR OF ALL OBSTRUCTIONS.
3. EXISTING STRUCTURE TO BE CHECKED BY OTHERS.
4. ALL CHANNEL & FITTINGS TO HAVE STANDARD UNISTRUT "PERMA-GREEN" FINISH AND ALL HARDWARE TO BE ELECTRO-GALVANIZED.

\* DESIGN LOAD VARIES BASED ON MAXIMUM SPANS - PLEASE CONTACT YOUR LOCAL UNISTRUT OFFICE FOR SPECIFIC LOADING DESIGN.

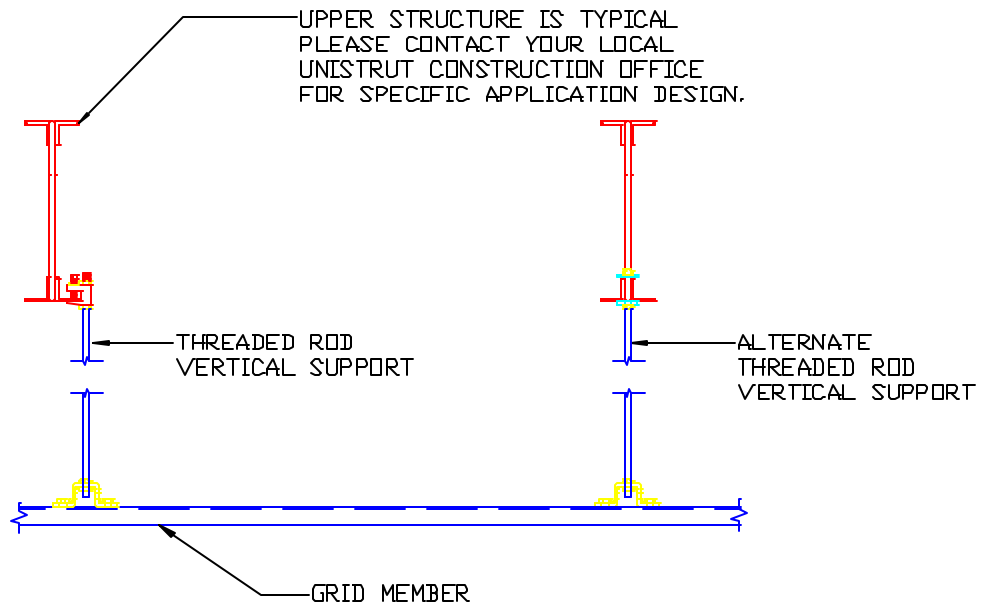

SECTION: UNISTRUT GRID SYSTEM

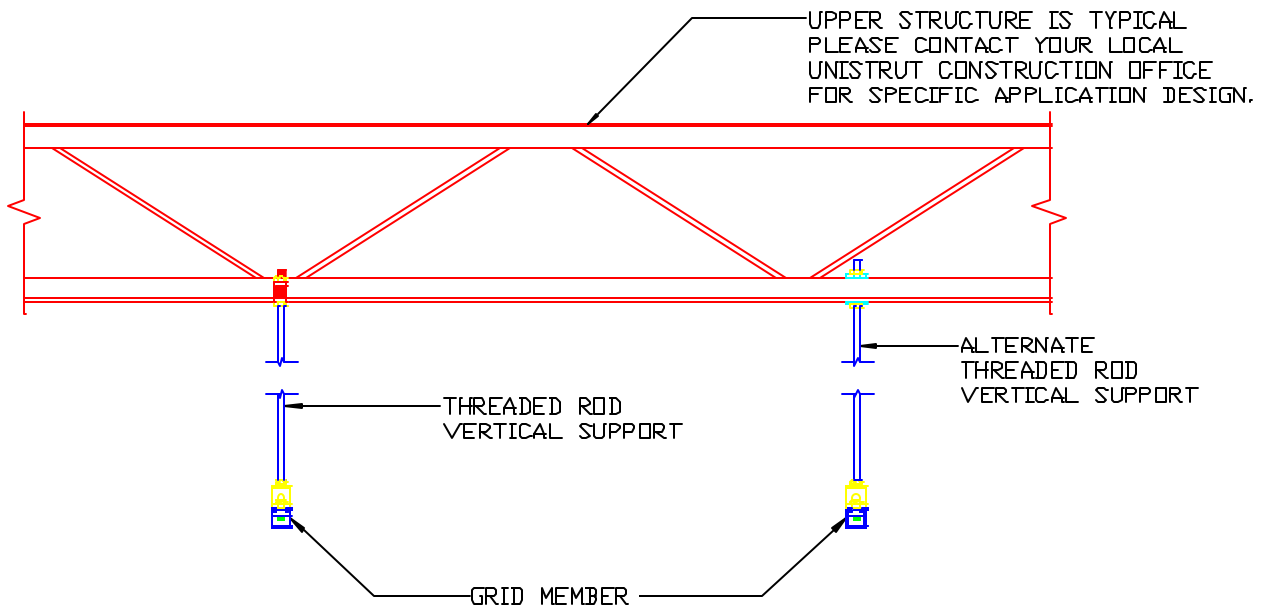

SECTION: UNISTRUT GRID SYSTEM

**UNISTRUT CORPORATION**  
 DESIGN & INSTALLATION  
 CONSTRUCTION DIVISION  
 PHONE: 1-800-468-9510

UNISTRUT 1 LEVEL 1 WAY  
 P1000 CEILING GRID

BY SB

DATE 12/05/03

TG-1L1W-00-SJ

SHEET  
 1 OF 1

GENERAL NOTES

1. THIS UNISTRUT SUPPORT SYSTEM IS DESIGNED TO SUPPORT A MAXIMUM UNIFORM LOAD OF \_\_\_ PSF. \*
2. AREA DIRECTLY ABOVE THE VERTICAL SUPPORT TO BE FREE AND CLEAR OF ALL OBSTRUCTIONS.
3. EXISTING STRUCTURE TO BE CHECKED BY OTHERS.
4. ALL CHANNEL & FITTINGS TO HAVE STANDARD UNISTRUT "PERMA-GREEN" FINISH AND ALL HARDWARE TO BE ELECTRO-GALVANIZED.

\* DESIGN LOAD VARIES BASED ON MAXIMUM SPANS - PLEASE CONTACT YOUR LOCAL UNISTRUT OFFICE FOR SPECIFIC LOADING DESIGN.

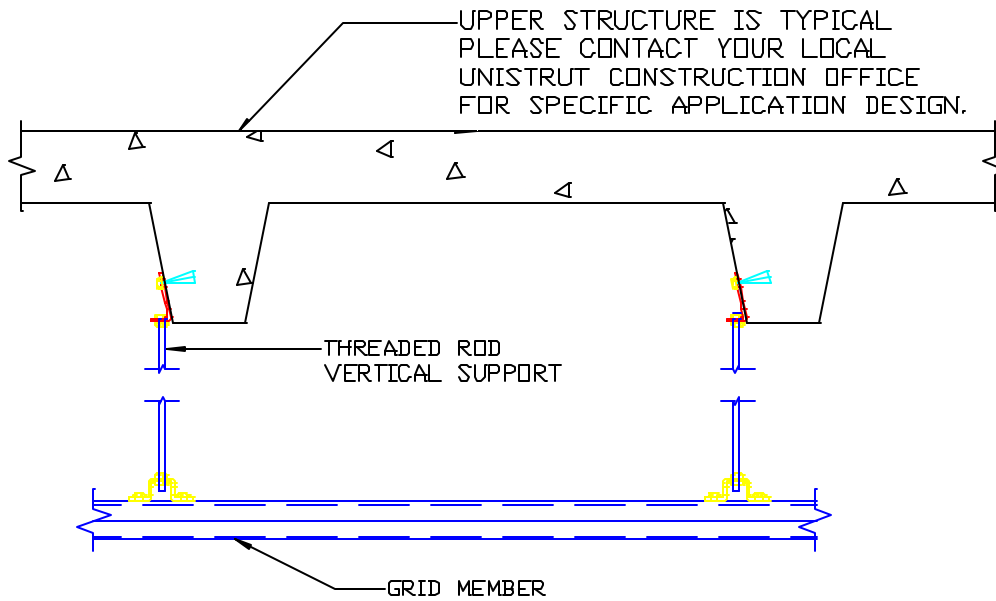

SECTION: UNISTRUT GRID SYSTEM

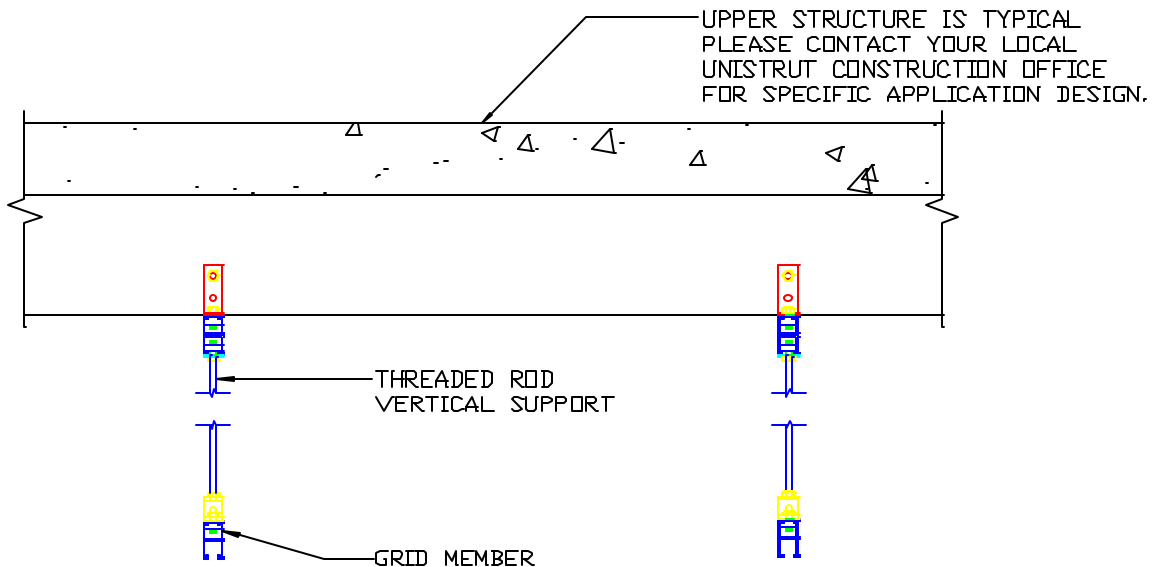

SECTION: UNISTRUT GRID SYSTEM

**UNISTRUT CORPORATION**  
 DESIGN & INSTALLATION  
 CONSTRUCTION DIVISION  
 PHONE: 1-800-468-9510

UNISTRUT 1 LEVEL 1 WAY  
 P1001 CEILING GRID

BY SB

DATE 12/05/03

TG-1L1W-01-CB

SHEET  
 1 OF 1

GENERAL NOTES

1. THIS UNISTRUT SUPPORT SYSTEM IS DESIGNED TO SUPPORT A MAXIMUM UNIFORM LOAD OF \_\_\_ PSF. \*
2. AREA DIRECTLY ABOVE THE VERTICAL SUPPORT TO BE FREE AND CLEAR OF ALL OBSTRUCTIONS.
3. EXISTING STRUCTURE TO BE CHECKED BY OTHERS.
4. ALL CHANNEL & FITTINGS TO HAVE STANDARD UNISTRUT "PERMA-GREEN" FINISH AND ALL HARDWARE TO BE ELECTRO-GALVANIZED.

\* DESIGN LOAD VARIES BASED ON MAXIMUM SPANS - PLEASE CONTACT YOUR LOCAL UNISTRUT CONSTRUCTION OFFICE FOR SPECIFIC LOADING DESIGN.

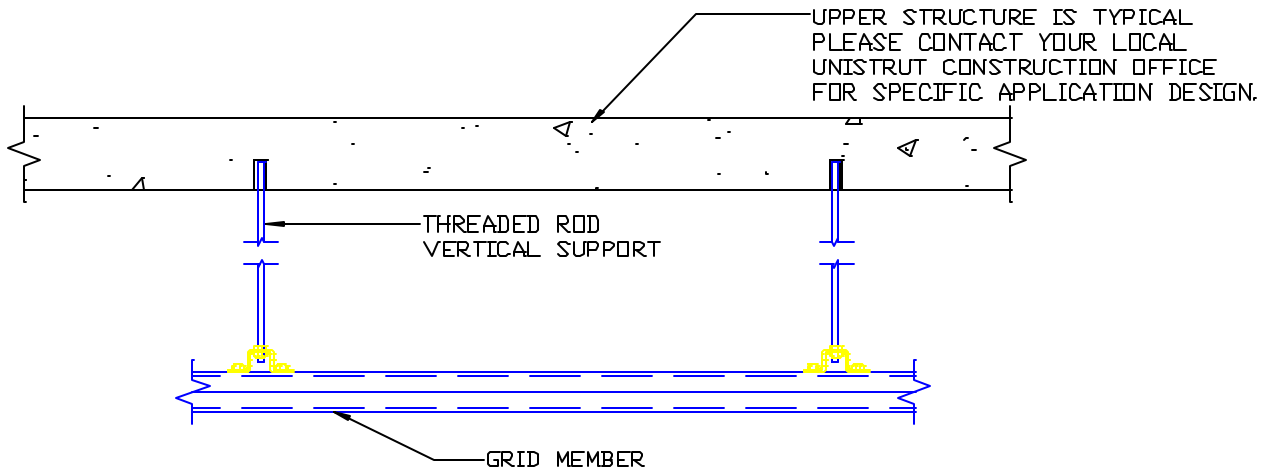

SECTION: UNISTRUT GRID SYSTEM

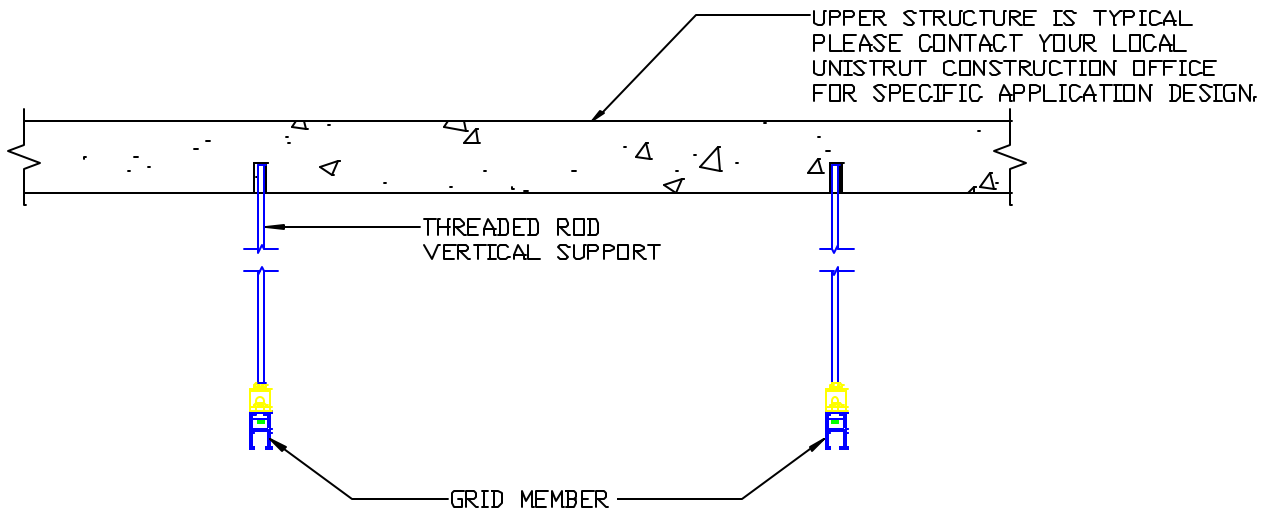

SECTION: UNISTRUT GRID SYSTEM

**UNISTRUT CORPORATION**

DESIGN & INSTALLATION  
CONSTRUCTION DIVISION  
PHONE: 1-800-468-9510

UNISTRUT 1 LEVEL 1 WAY  
P1001 CEILING GRID

BY SB

DATE 12/05/03

TG-1L1W-01-CS

SHEET  
1 OF 1

GENERAL NOTES

1. THIS UNISTRUT SUPPORT SYSTEM IS DESIGNED TO SUPPORT A MAXIMUM UNIFORM LOAD OF \_\_\_ PSF. \*
2. AREA DIRECTLY ABOVE THE VERTICAL SUPPORT TO BE FREE AND CLEAR OF ALL OBSTRUCTIONS.
3. EXISTING STRUCTURE TO BE CHECKED BY OTHERS.
4. ALL CHANNEL & FITTINGS TO HAVE STANDARD UNISTRUT "PERMA-GREEN" FINISH AND ALL HARDWARE TO BE ELECTRO-GALVANIZED.

\* DESIGN LOAD VARIES BASED ON MAXIMUM SPANS - PLEASE CONTACT YOUR LOCAL UNISTRUT OFFICE FOR SPECIFIC LOADING DESIGN.

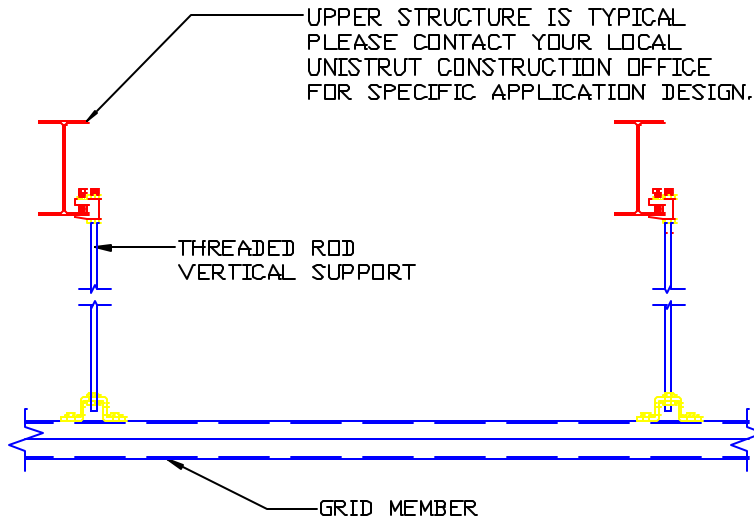

SECTION: UNISTRUT GRID SYSTEM

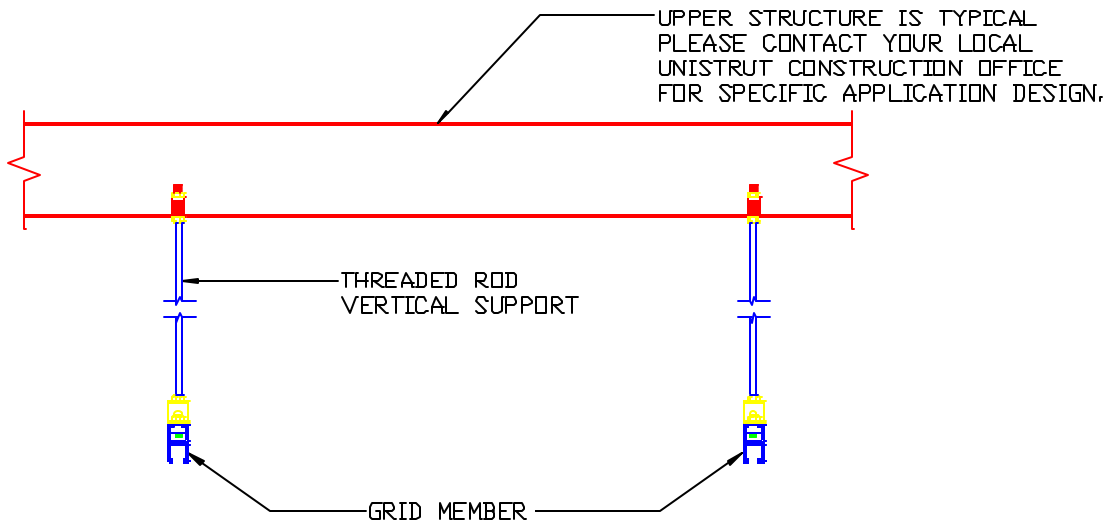

SECTION: UNISTRUT GRID SYSTEM

**UNISTRUT CORPORATION**

DESIGN & INSTALLATION  
CONSTRUCTION DIVISION  
PHONE: 1-800-468-9510

UNISTRUT 1 LEVEL 1 WAY  
P1001 CEILING GRID

BY SB

DATE 12/05/03

TG-1L1W-01-SB

SHEET  
1 OF 1

GENERAL NOTES

1. THIS UNISTRUT SUPPORT SYSTEM IS DESIGNED TO SUPPORT A MAXIMUM UNIFORM LOAD OF \_\_\_ PSF. \*
2. AREA DIRECTLY ABOVE THE VERTICAL SUPPORT TO BE FREE AND CLEAR OF ALL OBSTRUCTIONS.
3. EXISTING STRUCTURE TO BE CHECKED BY OTHERS.
4. ALL CHANNEL & FITTINGS TO HAVE STANDARD UNISTRUT "PERMA-GREEN" FINISH AND ALL HARDWARE TO BE ELECTRO-GALVANIZED.

\* DESIGN LOAD VARIES BASED ON MAXIMUM SPANS - PLEASE CONTACT YOUR LOCAL UNISTRUT OFFICE FOR SPECIFIC LOADING DESIGN.

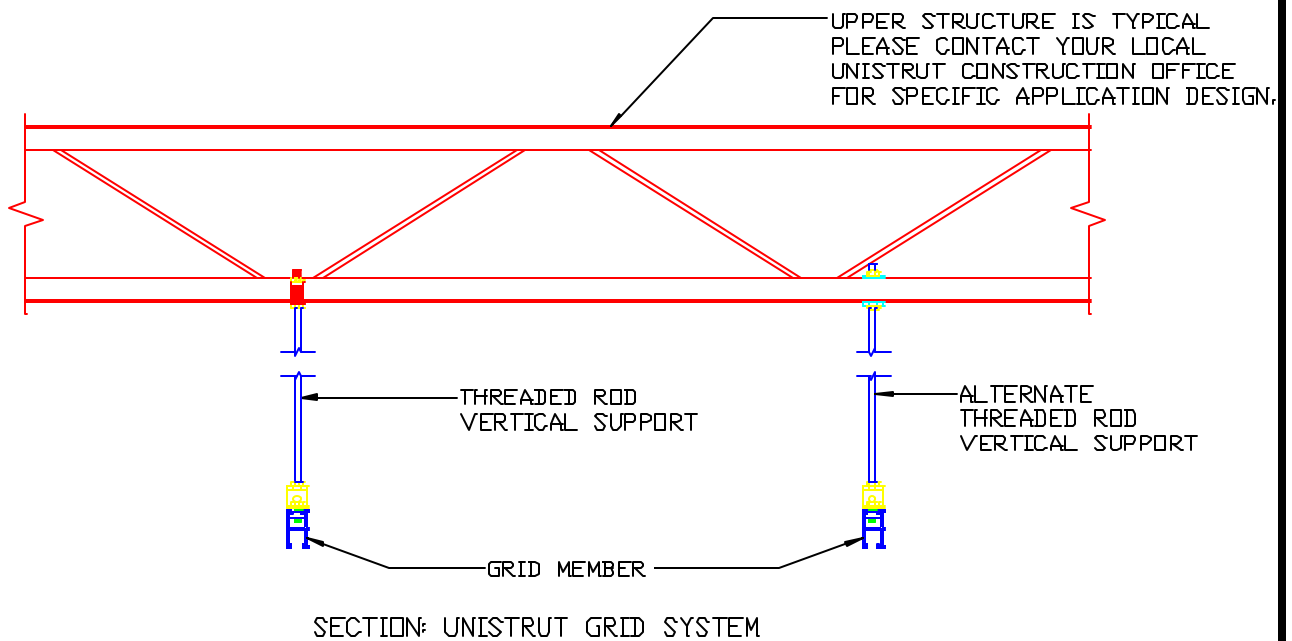
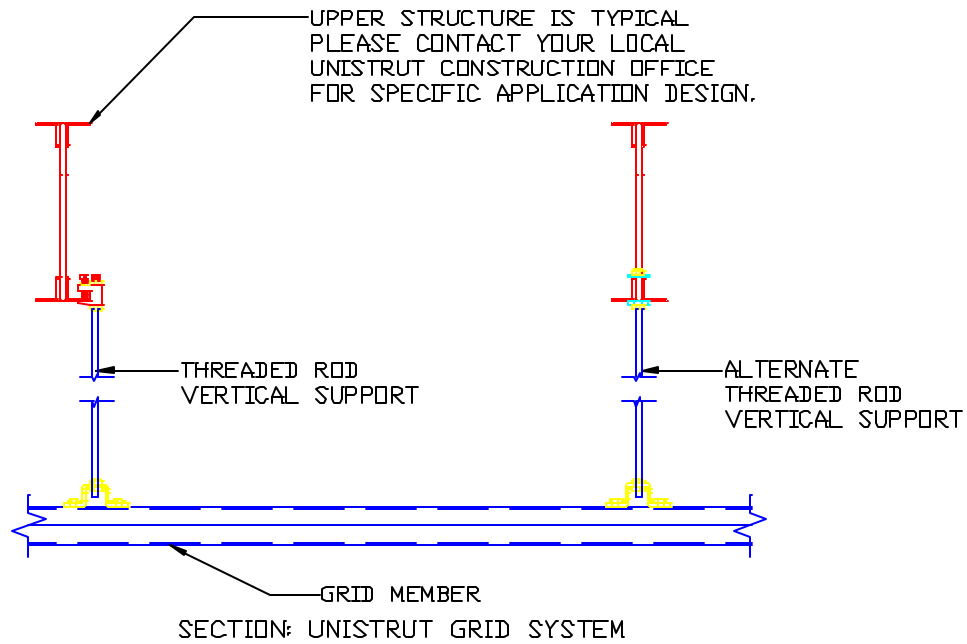

**UNISTRUT CORPORATION**  
 DESIGN & INSTALLATION  
 CONSTRUCTION DIVISION  
 PHONE: 1-800-468-9510

UNISTRUT 1 LEVEL 1 WAY  
 P1001 CEILING GRID

BY SB

DATE 12/05/03

TG-1L1W-01-SJ

SHEET  
 1 OF 1

GENERAL NOTES

1. THIS UNISTRUT SUPPORT SYSTEM IS DESIGNED TO SUPPORT A MAXIMUM UNIFORM LOAD OF \_\_\_ PSF. \*
2. AREA DIRECTLY ABOVE THE VERTICAL SUPPORT TO BE FREE AND CLEAR OF ALL OBSTRUCTIONS.
3. EXISTING STRUCTURE TO BE CHECKED BY OTHERS.
4. ALL CHANNEL & FITTINGS TO HAVE STANDARD UNISTRUT "PERMA-GREEN" FINISH AND ALL HARDWARE TO BE ELECTRO-GALVANIZED.

\* DESIGN LOAD VARIES BASED ON MAXIMUM SPANS - PLEASE CONTACT YOUR LOCAL UNISTRUT OFFICE FOR SPECIFIC LOADING DESIGN.

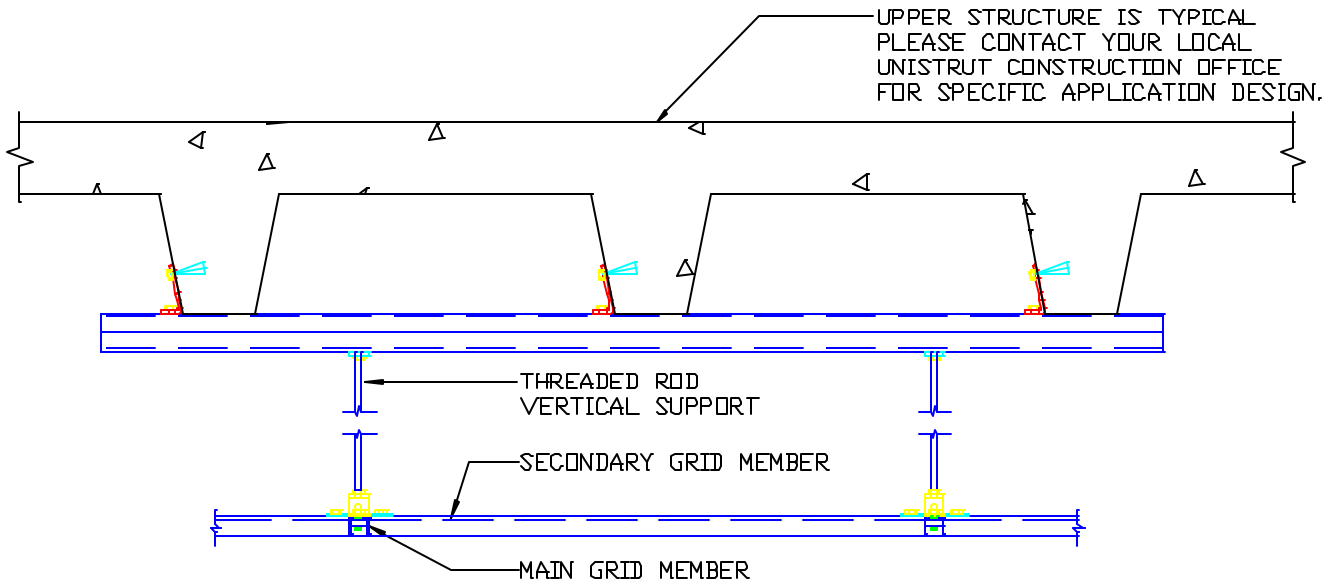

SECTION: UNISTRUT GRID SYSTEM

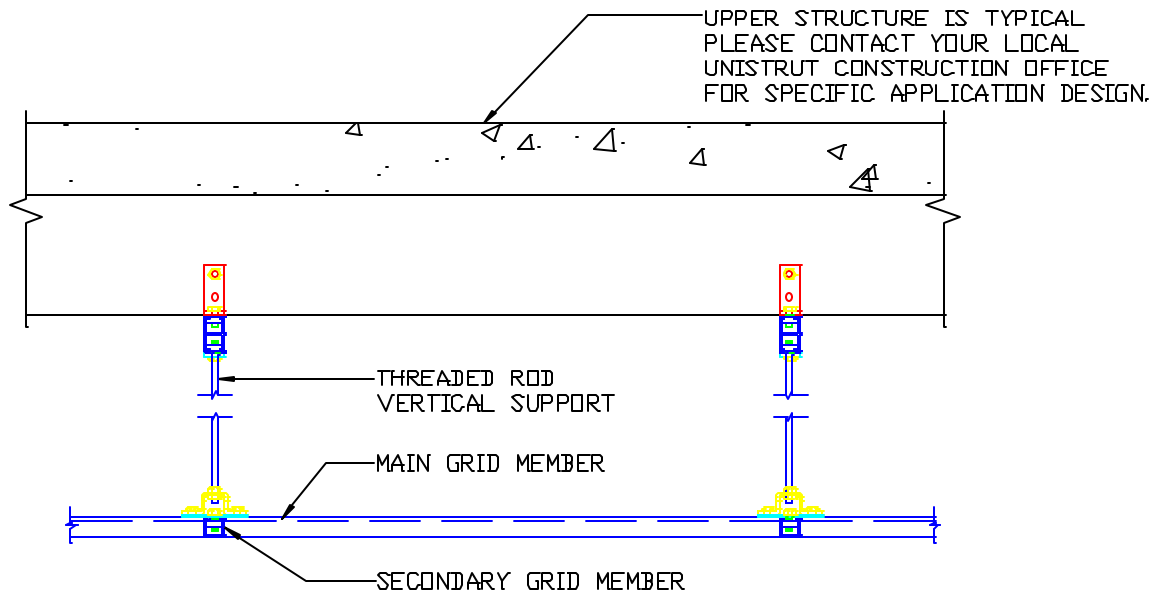

SECTION: UNISTRUT GRID SYSTEM

**UNISTRUT CORPORATION**  
 DESIGN & INSTALLATION  
 CONSTRUCTION DIVISION  
 PHONE: 1-800-468-9510

UNISTRUT 1 LEVEL 2 WAY  
 P1000 CEILING GRID

BY SB

DATE 12/05/03

TG-1L2W-00-CB

SHEET  
 1 OF 1

GENERAL NOTES

1. THIS UNISTRUT SUPPORT SYSTEM IS DESIGNED TO SUPPORT A MAXIMUM UNIFORM LOAD OF \_\_\_ PSF. \*
2. AREA DIRECTLY ABOVE THE VERTICAL SUPPORT TO BE FREE AND CLEAR OF ALL OBSTRUCTIONS.
3. EXISTING STRUCTURE TO BE CHECKED BY OTHERS.
4. ALL CHANNEL & FITTINGS TO HAVE STANDARD UNISTRUT "PERMA-GREEN" FINISH AND ALL HARDWARE TO BE ELECTRO-GALVANIZED.

\* DESIGN LOAD VARIES BASED ON MAXIMUM SPANS - PLEASE CONTACT YOUR LOCAL UNISTRUT CONSTRUCTION OFFICE FOR SPECIFIC LOADING DESIGN.

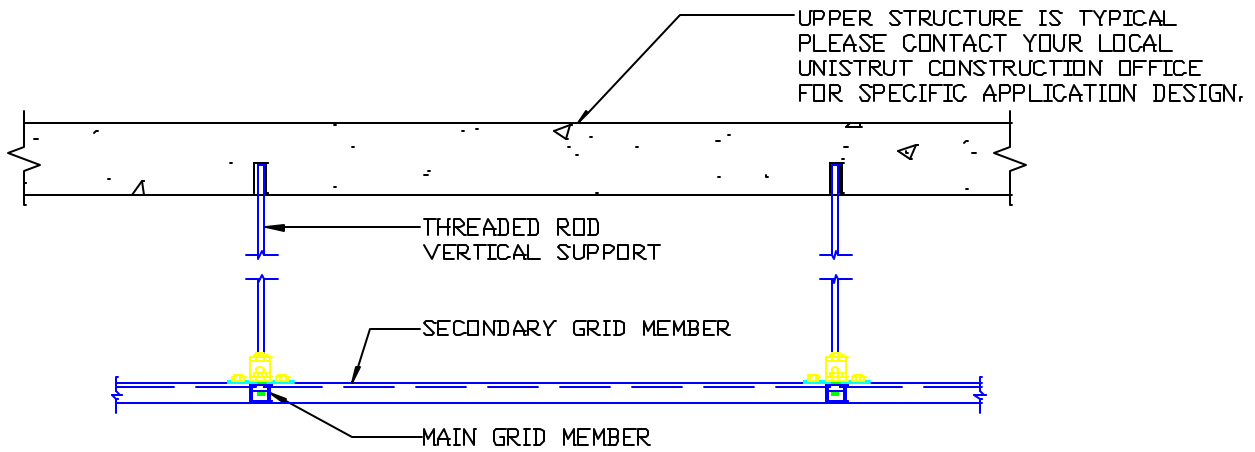

SECTION: UNISTRUT GRID SYSTEM

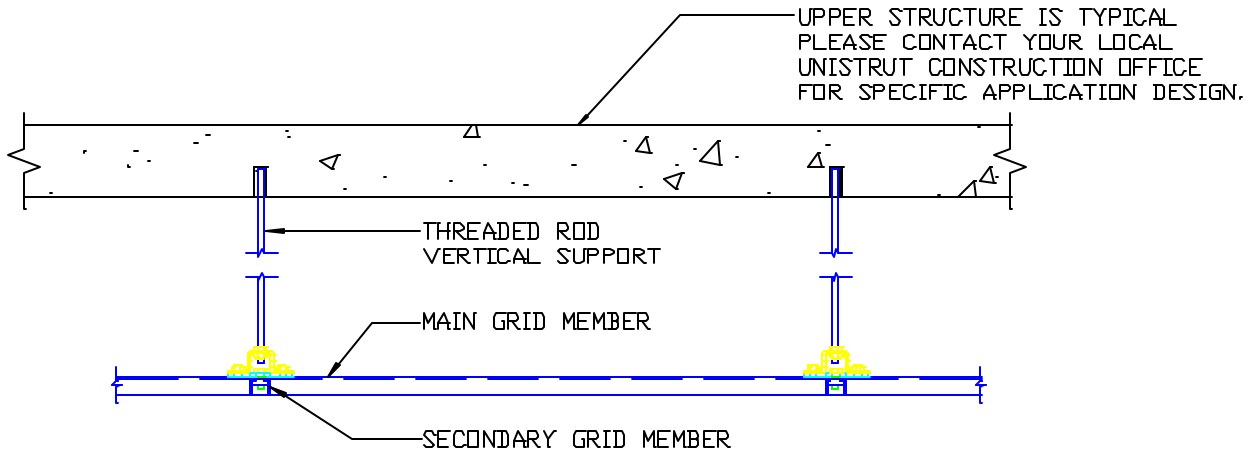

SECTION: UNISTRUT GRID SYSTEM

**UNISTRUT  
CORPORATION**

DESIGN & INSTALLATION  
CONSTRUCTION DIVISION  
PHONE: 1-800-468-9510

UNISTRUT 1 LEVEL 2 WAY  
P1000 CEILING GRID

BY SB

DATE 12/05/03

TG-1L2W-00-CS

SHEET  
1 OF 1

GENERAL NOTES

1. THIS UNISTRUT SUPPORT SYSTEM IS DESIGNED TO SUPPORT A MAXIMUM UNIFORM LOAD OF \_\_\_ PSF. \*
2. AREA DIRECTLY ABOVE THE VERTICAL SUPPORT TO BE FREE AND CLEAR OF ALL OBSTRUCTIONS.
3. EXISTING STRUCTURE TO BE CHECKED BY OTHERS.
4. ALL CHANNEL & FITTINGS TO HAVE STANDARD UNISTRUT "PERMA-GREEN" FINISH AND ALL HARDWARE TO BE ELECTRO-GALVANIZED.

\* DESIGN LOAD VARIES BASED ON MAXIMUM SPANS - PLEASE CONTACT YOUR LOCAL UNISTRUT OFFICE FOR SPECIFIC LOADING DESIGN.

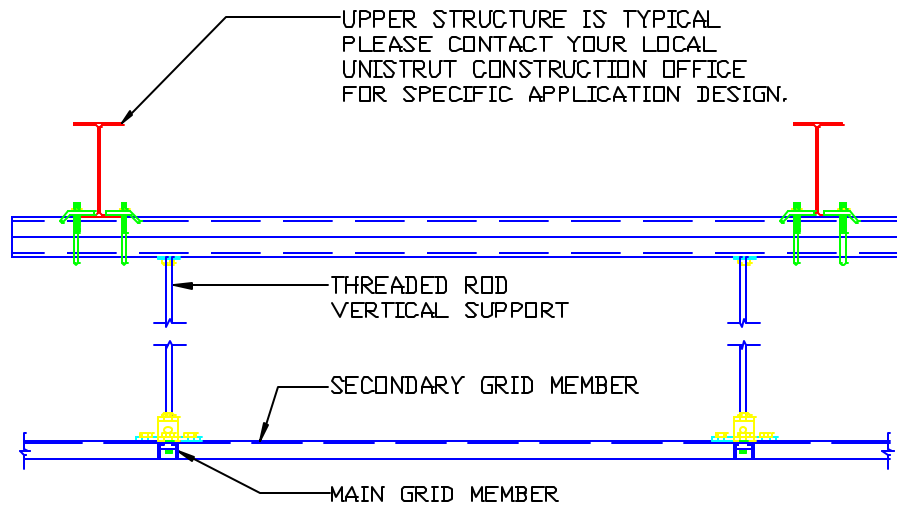

SECTION: UNISTRUT GRID SYSTEM

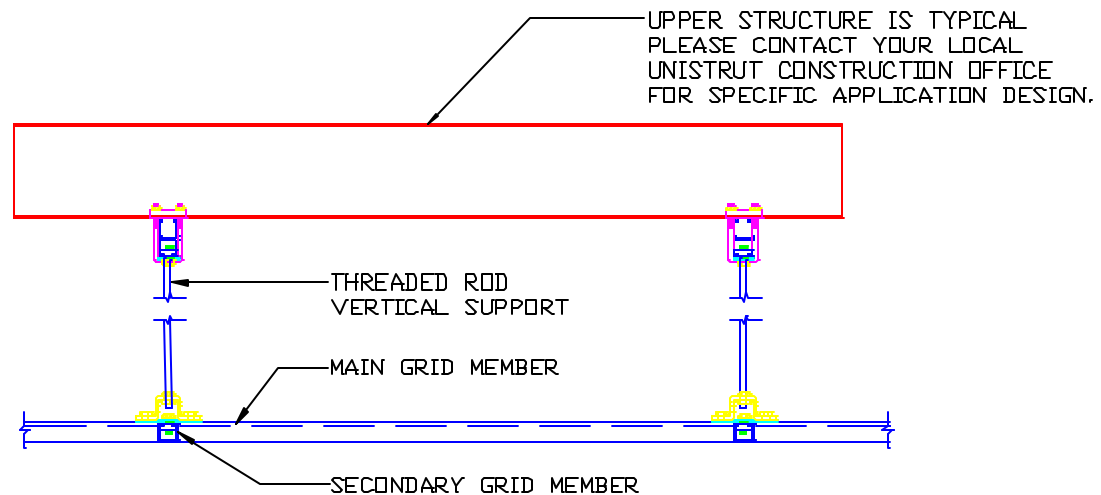

SECTION: UNISTRUT GRID SYSTEM

**UNISTRUT  
CORPORATION**

DESIGN & INSTALLATION  
CONSTRUCTION DIVISION  
PHONE: 1-800-468-9510

UNISTRUT 1 LEVEL 2 WAY  
P1000 CEILING GRID

BY SB

DATE 12/05/03

TG-1L2W-00-SB

SHEET  
1 OF 1

GENERAL NOTES

1. THIS UNISTRUT SUPPORT SYSTEM IS DESIGNED TO SUPPORT A MAXIMUM UNIFORM LOAD OF \_\_\_ PSF. \*
2. AREA DIRECTLY ABOVE THE VERTICAL SUPPORT TO BE FREE AND CLEAR OF ALL OBSTRUCTIONS.
3. EXISTING STRUCTURE TO BE CHECKED BY OTHERS.
4. ALL CHANNEL & FITTINGS TO HAVE STANDARD UNISTRUT "PERMA-GREEN" FINISH AND ALL HARDWARE TO BE ELECTRO-GALVANIZED.

\* DESIGN LOAD VARIES BASED ON MAXIMUM SPANS - PLEASE CONTACT YOUR LOCAL UNISTRUT OFFICE FOR SPECIFIC LOADING DESIGN.

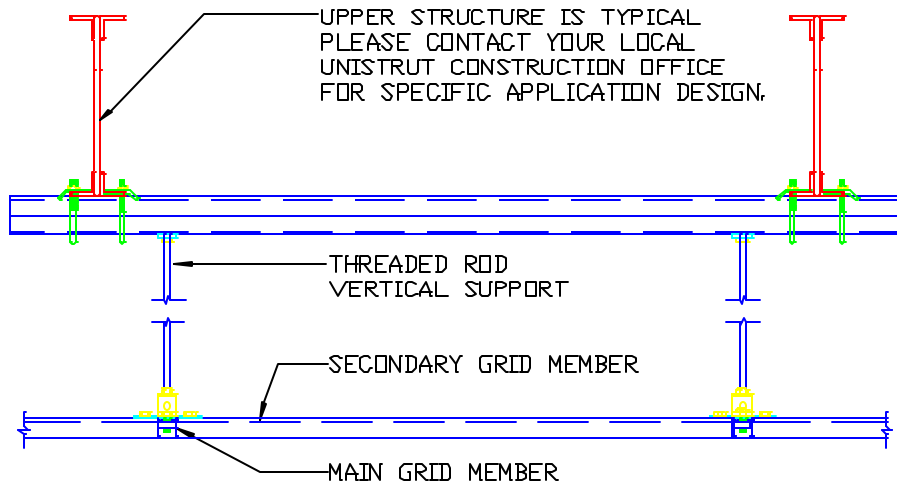

SECTION: UNISTRUT GRID SYSTEM

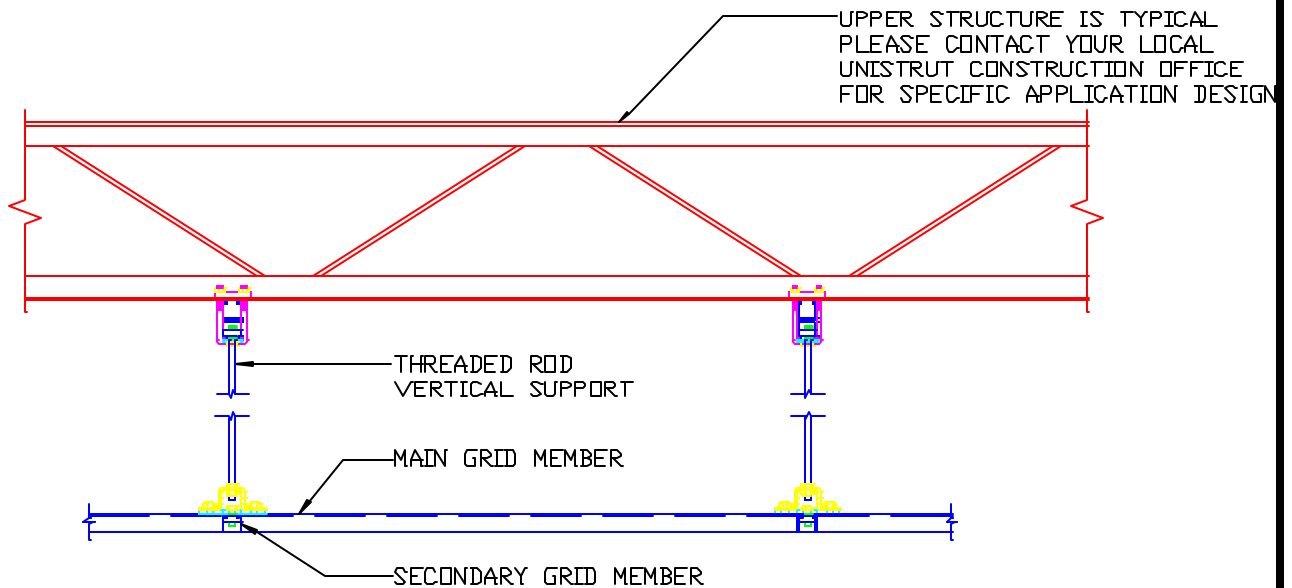

SECTION: UNISTRUT GRID SYSTEM

**UNISTRUT CORPORATION**  
 DESIGN & INSTALLATION  
 CONSTRUCTION DIVISION  
 PHONE 1-800-468-9510

UNISTRUT 1 LEVEL 2 WAY  
 P1000 CEILING GRID

BY SB

DATE 12/05/03

TG-1L2W-00-SJ

SHEET  
 1 OF 1

GENERAL NOTES

1. THIS UNISTRUT SUPPORT SYSTEM IS DESIGNED TO SUPPORT A MAXIMUM UNIFORM LOAD OF \_\_\_ PSF. \*
2. AREA DIRECTLY ABOVE THE VERTICAL SUPPORT TO BE FREE AND CLEAR OF ALL OBSTRUCTIONS.
3. EXISTING STRUCTURE TO BE CHECKED BY OTHERS.
4. ALL CHANNEL & FITTINGS TO HAVE STANDARD UNISTRUT "PERMA-GREEN" FINISH AND ALL HARDWARE TO BE ELECTRO-GALVANIZED.

\* DESIGN LOAD VARIES BASED ON MAXIMUM SPANS - PLEASE CONTACT YOUR LOCAL UNISTRUT OFFICE FOR SPECIFIC LOADING DESIGN.

UPPER STRUCTURE IS TYPICAL PLEASE CONTACT YOUR LOCAL UNISTRUT CONSTRUCTION OFFICE FOR SPECIFIC APPLICATION DESIGN.

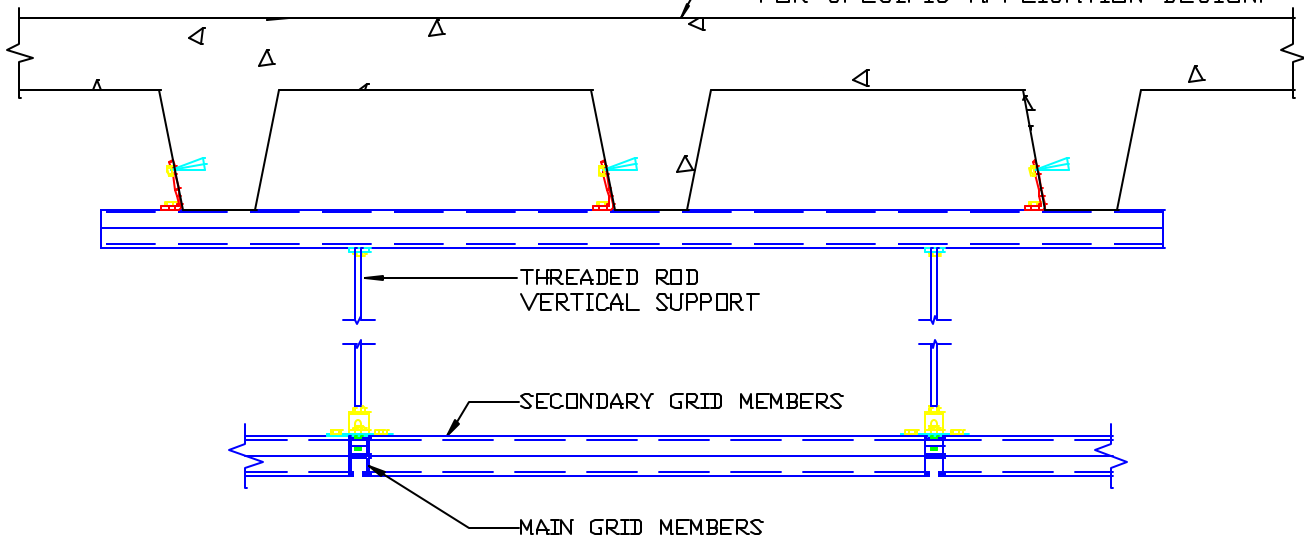

SECTION: UNISTRUT GRID SYSTEM

UPPER STRUCTURE IS TYPICAL PLEASE CONTACT YOUR LOCAL UNISTRUT CONSTRUCTION OFFICE FOR SPECIFIC APPLICATION DESIGN.

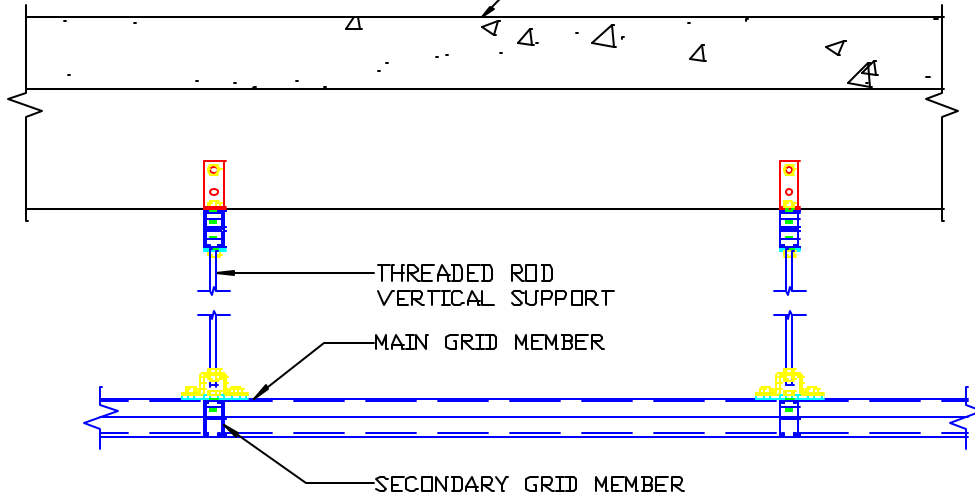

SECTION: UNISTRUT GRID SYSTEM

**UNISTRUT CORPORATION**

DESIGN & INSTALLATION  
CONSTRUCTION DIVISION  
PHONE: 1-800-468-9510

UNISTRUT 1 LEVEL 2 WAY  
P1001 CEILING GRID

BY SB

DATE 12/05/03

TG-1L2W-01-CB

SHEET  
1 OF 1

GENERAL NOTES

1. THIS UNISTRUT SUPPORT SYSTEM IS DESIGNED TO SUPPORT A MAXIMUM UNIFORM LOAD OF \_\_\_ PSF.\*
2. AREA DIRECTLY ABOVE THE VERTICAL SUPPORT TO BE FREE AND CLEAR OF ALL OBSTRUCTIONS.
3. EXISTING STRUCTURE TO BE CHECKED BY OTHERS.
4. ALL CHANNEL & FITTINGS TO HAVE STANDARD UNISTRUT "PERMA-GREEN" FINISH AND ALL HARDWARE TO BE ELECTRO-GALVANIZED.

\* DESIGN LOAD VARIES BASED ON MAXIMUM SPANS - PLEASE CONTACT YOUR LOCAL UNISTRUT CONSTRUCTION OFFICE FOR SPECIFIC LOADING DESIGN.

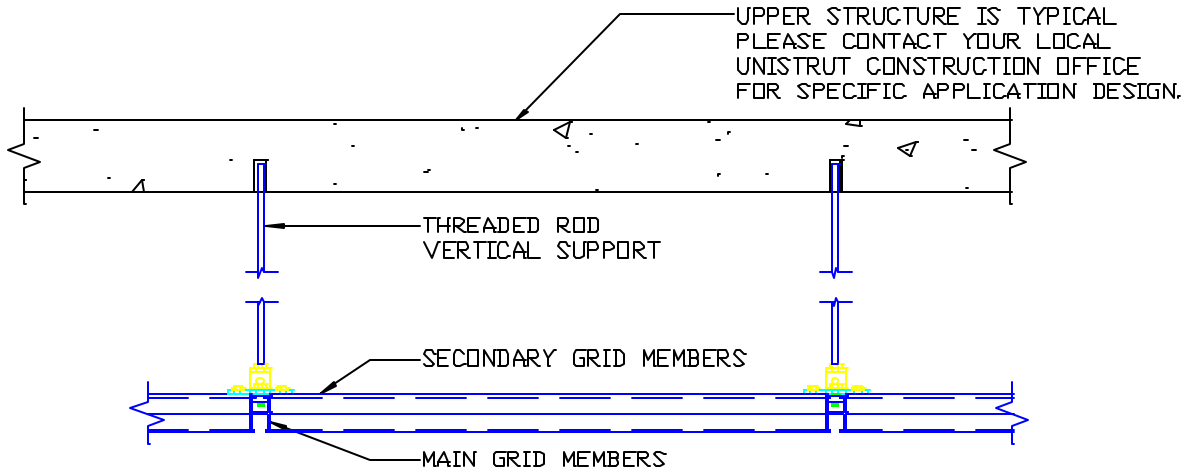

SECTION: UNISTRUT GRID SYSTEM

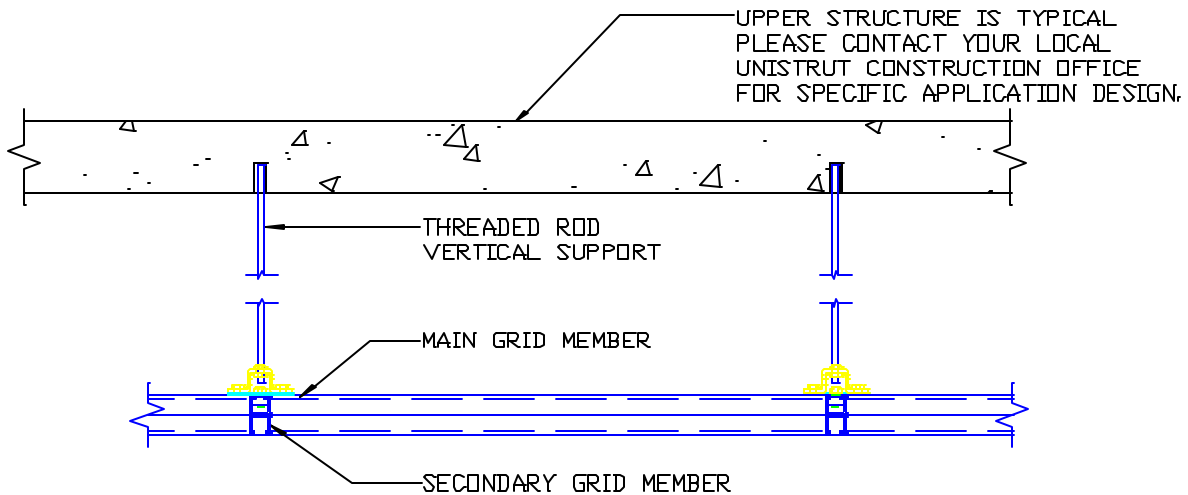

SECTION: UNISTRUT GRID SYSTEM

**UNISTRUT CORPORATION**

DESIGN & INSTALLATION  
CONSTRUCTION DIVISION  
PHONE: 1-800-468-9510

UNISTRUT 1 LEVEL 2 WAY  
P1001 CEILING GRID

BY SB

DATE 12/05/03

TG-1L2W-01-CS

SHEET  
1 OF 1

GENERAL NOTES

1. THIS UNISTRUT SUPPORT SYSTEM IS DESIGNED TO SUPPORT A MAXIMUM UNIFORM LOAD OF \_\_\_ PSF. \*
2. AREA DIRECTLY ABOVE THE VERTICAL SUPPORT TO BE FREE AND CLEAR OF ALL OBSTRUCTIONS.
3. EXISTING STRUCTURE TO BE CHECKED BY OTHERS.
4. ALL CHANNEL & FITTINGS TO HAVE STANDARD UNISTRUT "PERMA-GREEN" FINISH AND ALL HARDWARE TO BE ELECTRO-GALVANIZED.

\* DESIGN LOAD VARIES BASED ON MAXIMUM SPANS - PLEASE CONTACT YOUR LOCAL UNISTRUT OFFICE FOR SPECIFIC LOADING DESIGN.

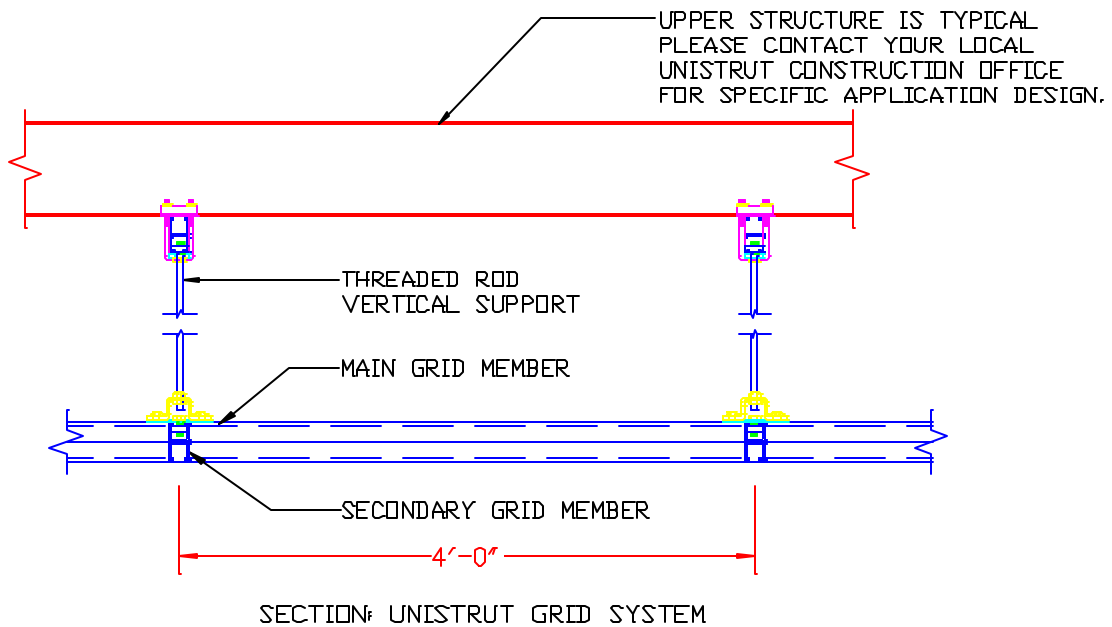
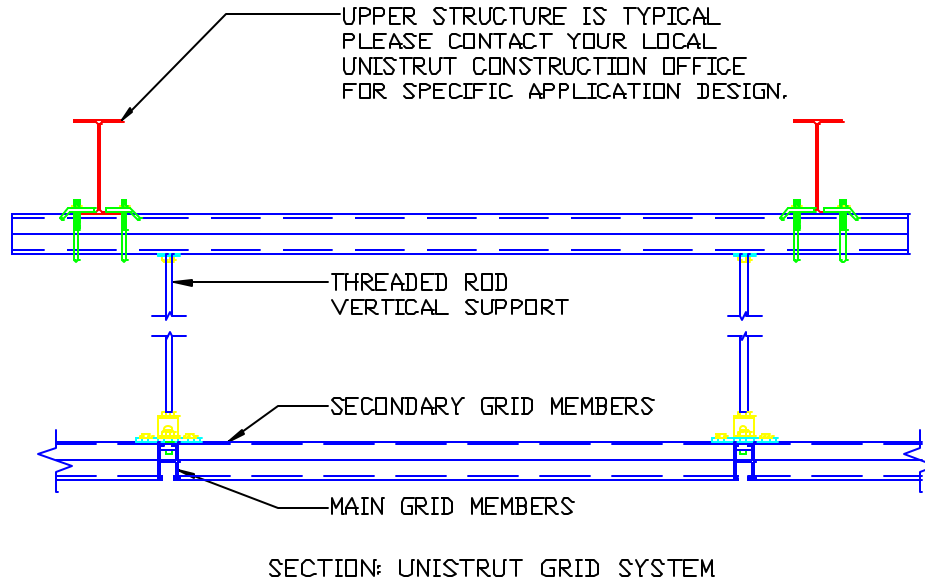

**UNISTRUT  
CORPORATION**  
DESIGN & INSTALLATION  
CONSTRUCTION DIVISION  
PHONE: 1-800-468-9510

UNISTRUT 1 LEVEL 2 WAY  
P1001 CEILING GRID

BY SB

DATE 12/05/03

TG-1L2W-01-SB

SHEET  
1 OF 1

GENERAL NOTES

1. THIS UNISTRUT SUPPORT SYSTEM IS DESIGNED TO SUPPORT A MAXIMUM UNIFORM LOAD OF \_\_\_ PSF.\*
2. AREA DIRECTLY ABOVE THE VERTICAL SUPPORT TO BE FREE AND CLEAR OF ALL OBSTRUCTIONS.
3. EXISTING STRUCTURE TO BE CHECKED BY OTHERS.
4. ALL CHANNEL & FITTINGS TO HAVE STANDARD UNISTRUT "PERMA-GREEN" FINISH AND ALL HARDWARE TO BE ELECTRO-GALVANIZED.

\* DESIGN LOAD VARIES BASED ON MAXIMUM SPANS - PLEASE CONTACT YOUR LOCAL UNISTRUT OFFICE FOR SPECIFIC LOADING DESIGN.

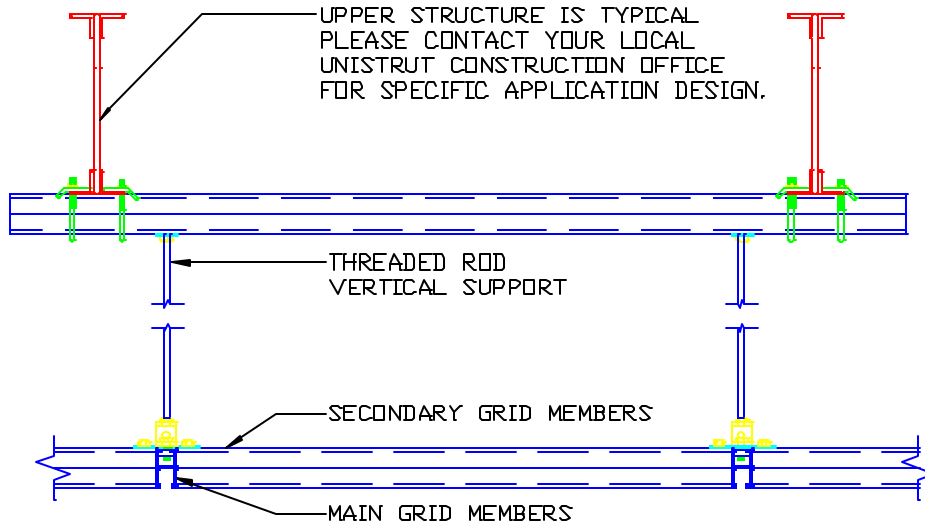

SECTION: UNISTRUT GRID SYSTEM

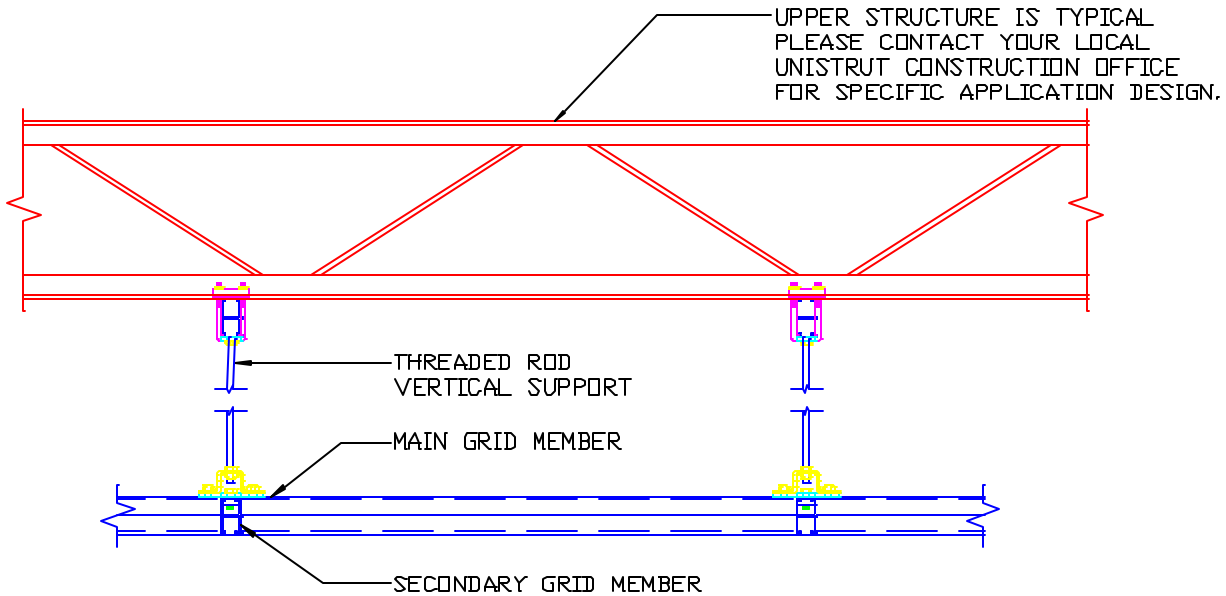

SECTION: UNISTRUT GRID SYSTEM

**UNISTRUT CORPORATION**

DESIGN & INSTALLATION  
CONSTRUCTION DIVISION  
PHONE: 1-800-468-9510

UNISTRUT 1 LEVEL 2 WAY  
P1001 CEILING GRID

BY SB

DATE 12/05/03

TG-1L2W-01-SJ

SHEET  
1 OF 1

GENERAL NOTES

1. THIS UNISTRUT SUPPORT SYSTEM IS DESIGNED TO SUPPORT A MAXIMUM UNIFORM LOAD OF \_\_\_ PSF. \*
2. AREA DIRECTLY ABOVE THE VERTICAL SUPPORT TO BE FREE AND CLEAR OF ALL OBSTRUCTIONS.
3. EXISTING STRUCTURE TO BE CHECKED BY OTHERS.
4. ALL CHANNEL & FITTINGS TO HAVE STANDARD UNISTRUT "PERMA-GREEN" FINISH AND ALL HARDWARE TO BE ELECTRO-GALVANIZED.

\* DESIGN LOAD VARIES BASED ON MAXIMUM SPANS - PLEASE CONTACT YOUR LOCAL UNISTRUT OFFICE FOR SPECIFIC LOADING DESIGN.

UPPER STRUCTURE IS TYPICAL PLEASE CONTACT YOUR LOCAL UNISTRUT CONSTRUCTION OFFICE FOR SPECIFIC APPLICATION DESIGN.

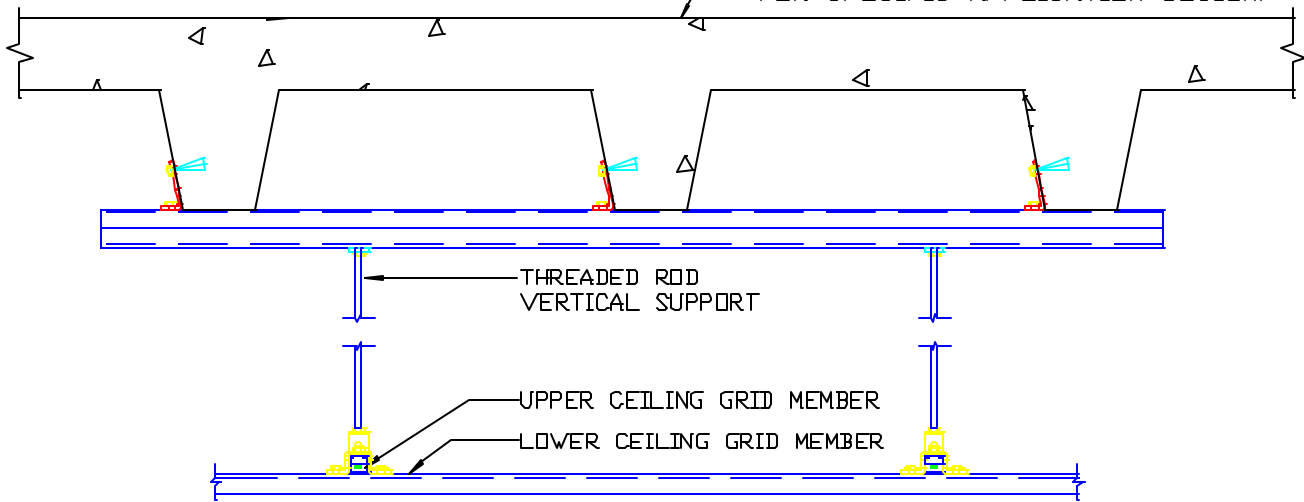

SECTION: UNISTRUT GRID SYSTEM

UPPER STRUCTURE IS TYPICAL PLEASE CONTACT YOUR LOCAL UNISTRUT CONSTRUCTION OFFICE FOR SPECIFIC APPLICATION DESIGN.

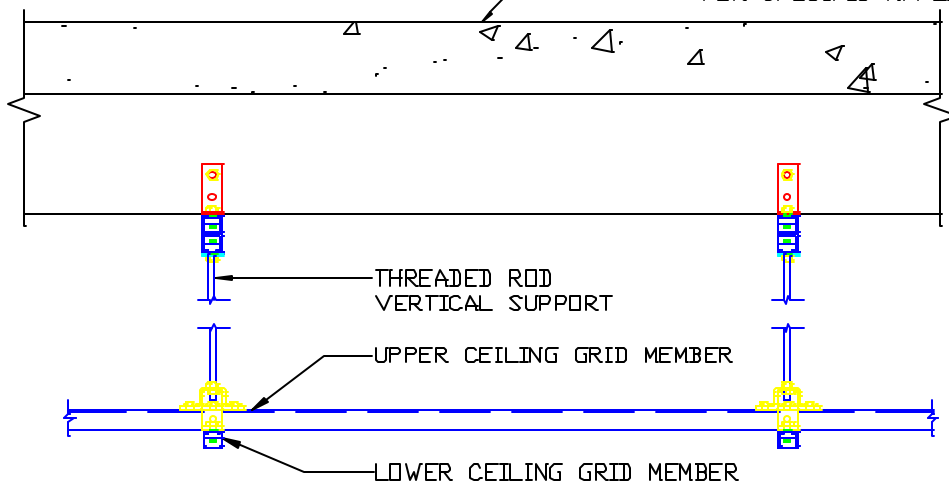

SECTION: UNISTRUT GRID SYSTEM

**UNISTRUT CORPORATION**

DESIGN & INSTALLATION  
CONSTRUCTION DIVISION  
PHONE: 1-800-468-9510

UNISTRUT 2 LEVEL 2 WAY  
P1000 CEILING GRID

BY SB

DATE 12/08/03

TG-2L2W-00-CB

SHEET  
1 OF 1

GENERAL NOTES

1. THIS UNISTRUT SUPPORT SYSTEM IS DESIGNED TO SUPPORT A MAXIMUM UNIFORM LOAD OF \_\_\_ PSF. \*
2. AREA DIRECTLY ABOVE THE VERTICAL SUPPORT TO BE FREE AND CLEAR OF ALL OBSTRUCTIONS.
3. EXISTING STRUCTURE TO BE CHECKED BY OTHERS.
4. ALL CHANNEL & FITTINGS TO HAVE STANDARD UNISTRUT "PERMA-GREEN" FINISH AND ALL HARDWARE TO BE ELECTRO-GALVANIZED.

\* DESIGN LOAD VARIES BASED ON MAXIMUM SPANS - PLEASE CONTACT YOUR LOCAL UNISTRUT OFFICE FOR SPECIFIC LOADING DESIGN.

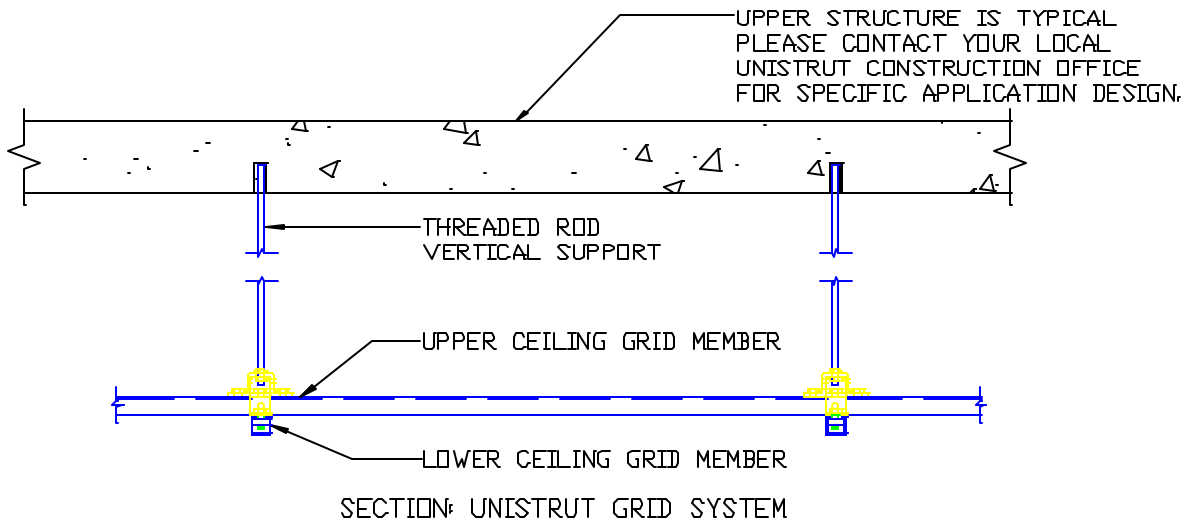
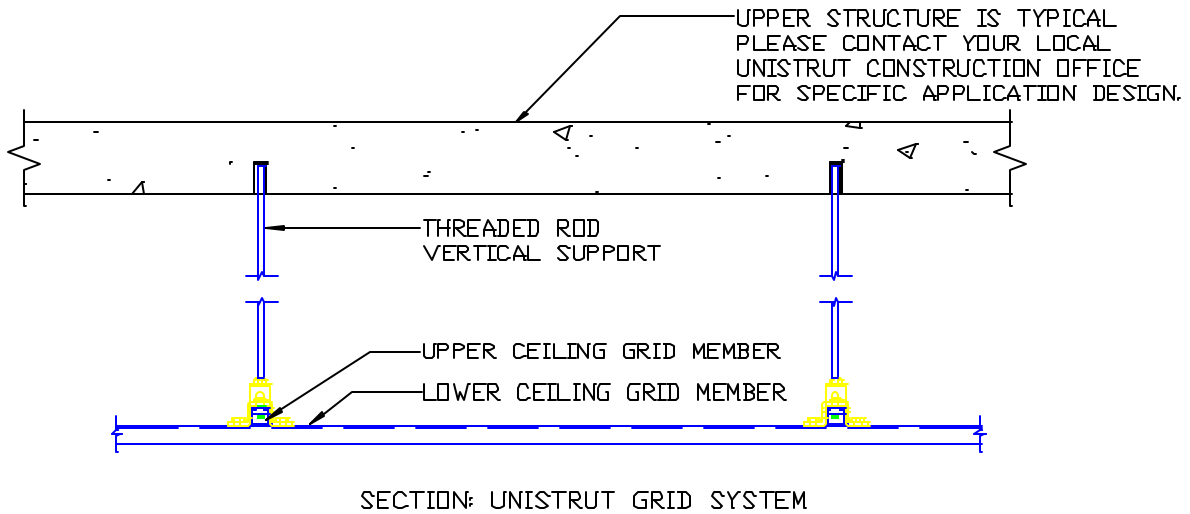

**UNISTRUT CORPORATION**  
DESIGN & INSTALLATION  
CONSTRUCTION DIVISION  
PHONE: 1-800-468-9510

UNISTRUT 2 LEVEL 2 WAY  
P1000 CEILING GRID

BY SB

DATE 12/08/03

TG-2L2W-00-CS

SHEET  
1 OF 1

GENERAL NOTES

1. THIS UNISTRUT SUPPORT SYSTEM IS DESIGNED TO SUPPORT A MAXIMUM UNIFORM LOAD OF \_\_\_ PSF. \*
2. AREA DIRECTLY ABOVE THE VERTICAL SUPPORT TO BE FREE AND CLEAR OF ALL OBSTRUCTIONS.
3. EXISTING STRUCTURE TO BE CHECKED BY OTHERS.
4. ALL CHANNEL & FITTINGS TO HAVE STANDARD UNISTRUT "PERMA-GREEN" FINISH AND ALL HARDWARE TO BE ELECTRO-GALVANIZED.

\* DESIGN LOAD VARIES BASED ON MAXIMUM SPANS - PLEASE CONTACT YOUR LOCAL UNISTRUT OFFICE FOR SPECIFIC LOADING DESIGN.

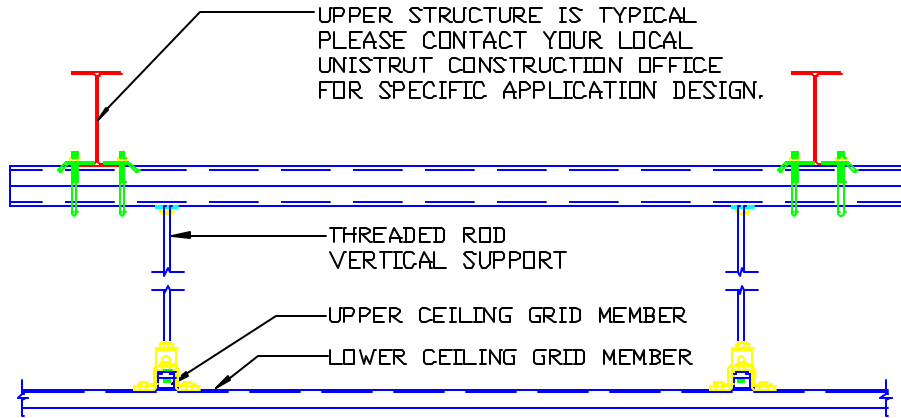

SECTION: UNISTRUT GRID SYSTEM

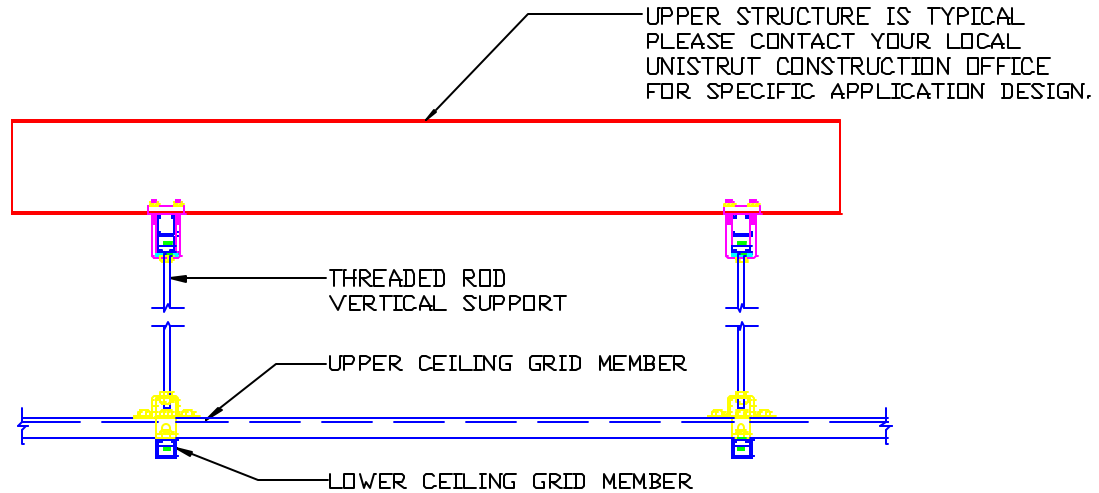

SECTION: UNISTRUT GRID SYSTEM

**UNISTRUT  
CORPORATION**

DESIGN & INSTALLATION  
CONSTRUCTION DIVISION  
PHONE: 1-800-468-9510

UNISTRUT 2 LEVEL 2 WAY  
P1000 CEILING GRID

BY SB

DATE 12/08/03

TG-2L2W-00-SB

SHEET  
1 OF 1

GENERAL NOTES

1. THIS UNISTRUT SUPPORT SYSTEM IS DESIGNED TO SUPPORT A MAXIMUM UNIFORM LOAD OF \_\_\_ PSF. \*
2. AREA DIRECTLY ABOVE THE VERTICAL SUPPORT TO BE FREE AND CLEAR OF ALL OBSTRUCTIONS.
3. EXISTING STRUCTURE TO BE CHECKED BY OTHERS.
4. ALL CHANNEL & FITTINGS TO HAVE STANDARD UNISTRUT "PERMA-GREEN" FINISH AND ALL HARDWARE TO BE ELECTRO-GALVANIZED.

\* DESIGN LOAD VARIES BASED ON MAXIMUM SPANS - PLEASE CONTACT YOUR LOCAL UNISTRUT OFFICE FOR SPECIFIC LOADING DESIGN.

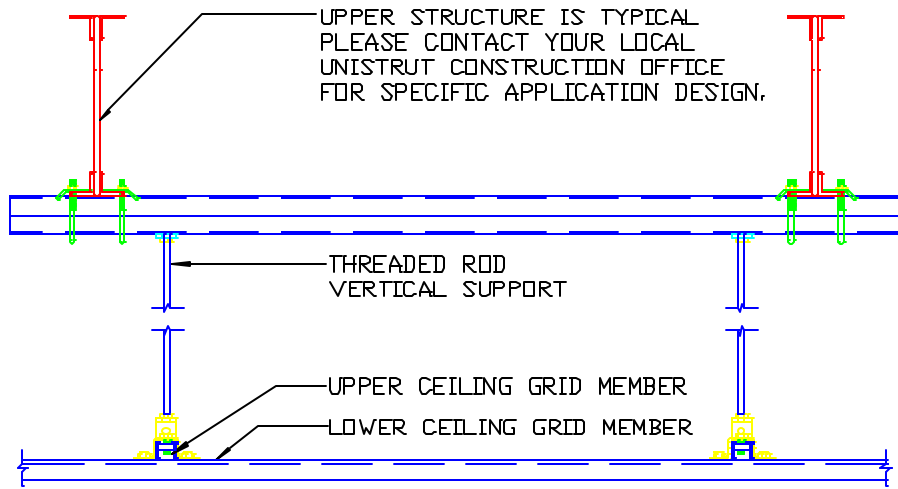

SECTION: UNISTRUT GRID SYSTEM

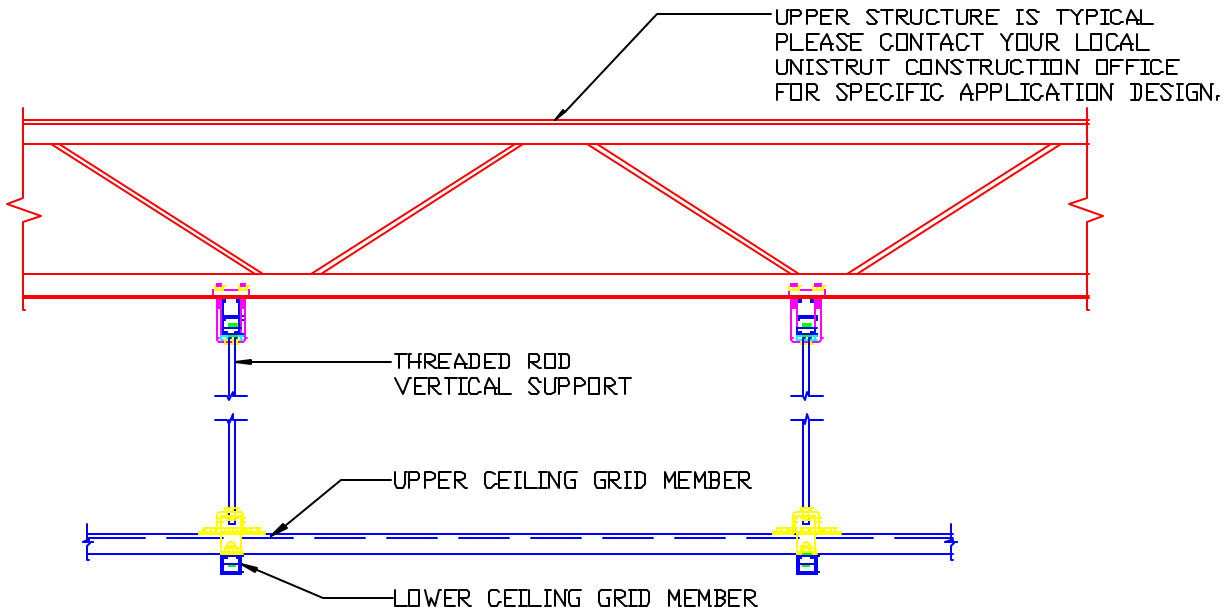

SECTION: UNISTRUT GRID SYSTEM

**UNISTRUT CORPORATION**

DESIGN & INSTALLATION  
CONSTRUCTION DIVISION  
PHONE: 1-800-468-9510

UNISTRUT 2 LEVEL 2 WAY  
P1000 CEILING GRID

BY SB

DATE 12/08/03

TG-2L2W-00-SJ

SHEET  
1 OF 1

GENERAL NOTES

1. THIS UNISTRUT SUPPORT SYSTEM IS DESIGNED TO SUPPORT A MAXIMUM UNIFORM LOAD OF \_\_\_ PSF. \*
2. AREA DIRECTLY ABOVE THE VERTICAL SUPPORT TO BE FREE AND CLEAR OF ALL OBSTRUCTIONS.
3. EXISTING STRUCTURE TO BE CHECKED BY OTHERS.
4. ALL CHANNEL & FITTINGS TO HAVE STANDARD UNISTRUT "PERMA-GREEN" FINISH AND ALL HARDWARE TO BE ELECTRO-GALVANIZED.

\* DESIGN LOAD VARIES BASED ON MAXIMUM SPANS - PLEASE CONTACT YOUR LOCAL UNISTRUT OFFICE FOR SPECIFIC LOADING DESIGN.

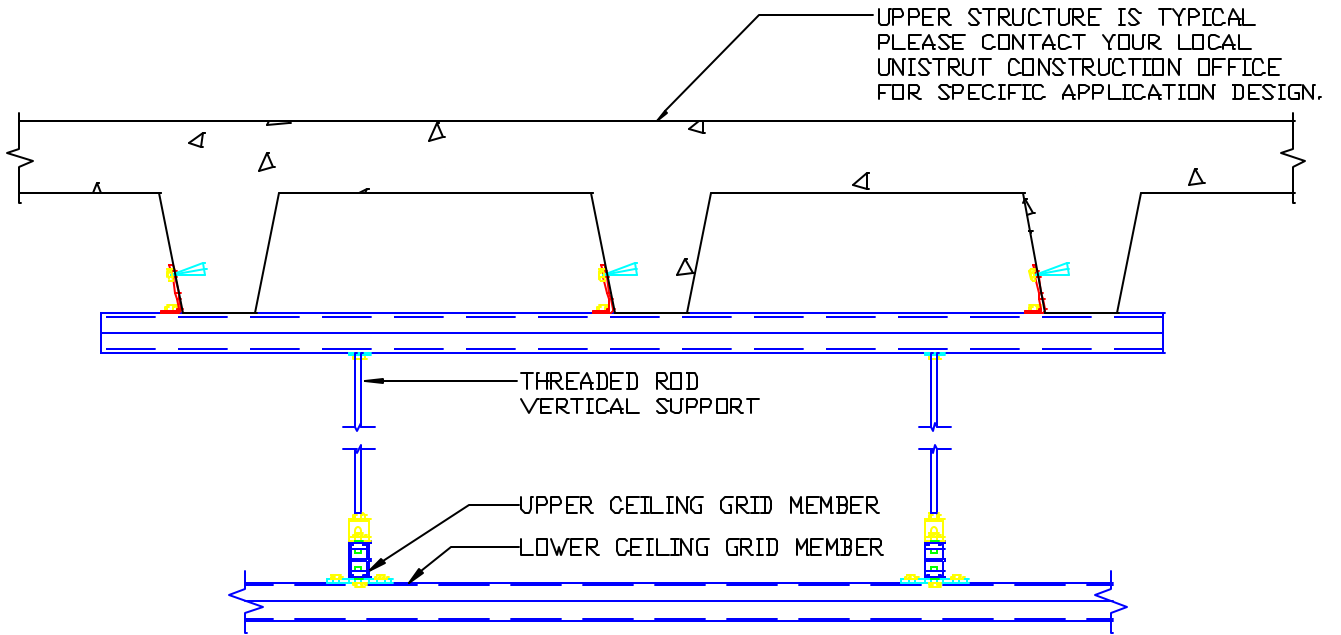

SECTION: UNISTRUT GRID SYSTEM

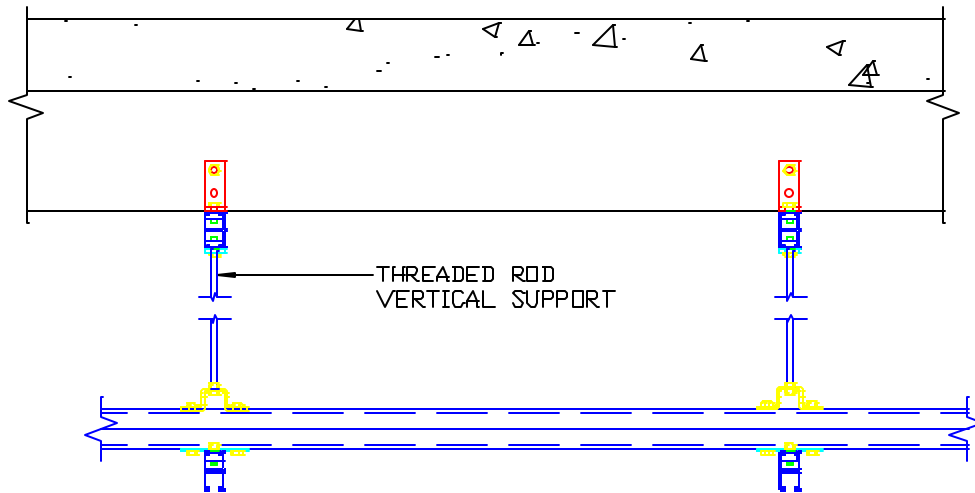

SECTION: UNISTRUT GRID SYSTEM

**UNISTRUT CORPORATION**

DESIGN & INSTALLATION  
 CONSTRUCTION DIVISION  
 PHONE: 1-800-468-9510

UNISTRUT 2 LEVEL 2 WAY  
 P1001 CEILING GRID

BY SB

DATE 12/08/03

TG-2L2W-01-CB

SHEET  
 1 OF 1

GENERAL NOTES

1. THIS UNISTRUT SUPPORT SYSTEM IS DESIGNED TO SUPPORT A MAXIMUM UNIFORM LOAD OF \_\_\_ PSF.\*
2. AREA DIRECTLY ABOVE THE VERTICAL SUPPORT TO BE FREE AND CLEAR OF ALL OBSTRUCTIONS.
3. EXISTING STRUCTURE TO BE CHECKED BY OTHERS.
4. ALL CHANNEL & FITTINGS TO HAVE STANDARD UNISTRUT "PERMA-GREEN" FINISH AND ALL HARDWARE TO BE ELECTRO-GALVANIZED.

\* DESIGN LOAD VARIES BASED ON MAXIMUM SPANS - PLEASE CONTACT YOUR LOCAL UNISTRUT OFFICE FOR SPECIFIC LOADING DESIGN.

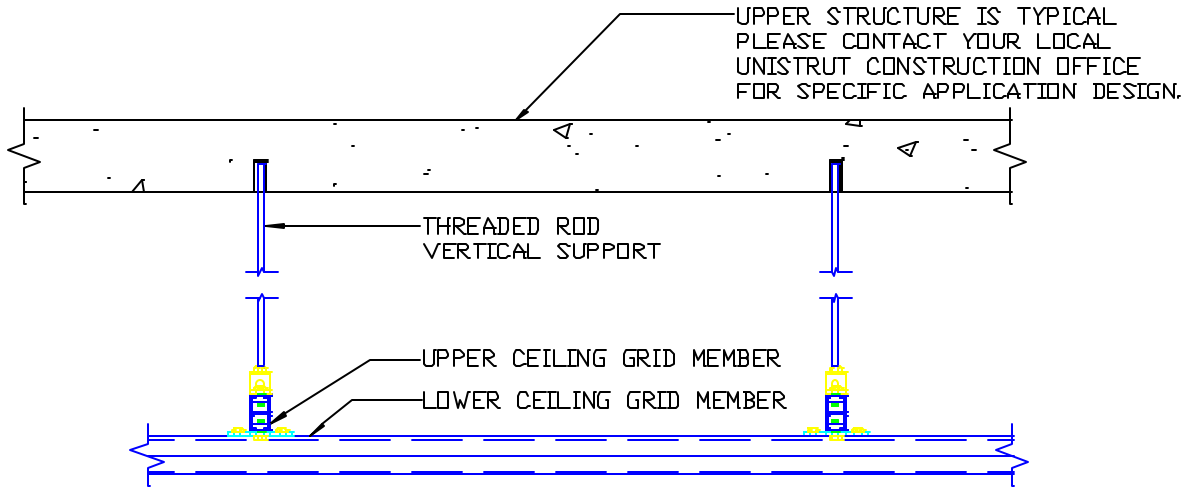

SECTION: UNISTRUT GRID SYSTEM

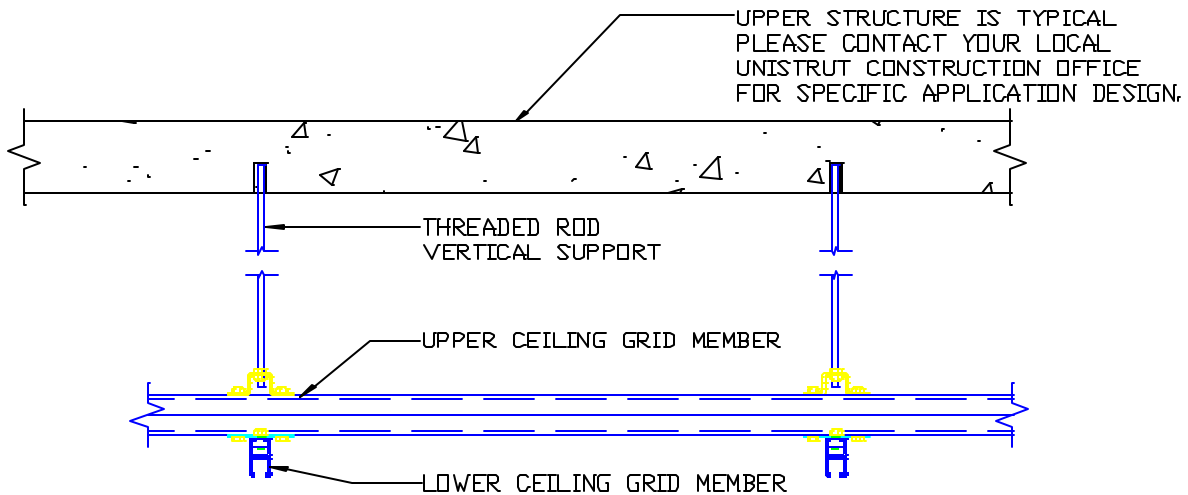

SECTION: UNISTRUT GRID SYSTEM

**UNISTRUT  
CORPORATION**

DESIGN & INSTALLATION  
CONSTRUCTION DIVISION  
PHONE: 1-800-468-9510

UNISTRUT 2 LEVEL 2 WAY  
P1001 CEILING GRID

BY SB

DATE 12/08/03

TG-2L2W-01-CS

SHEET  
1 OF 1

GENERAL NOTES

1. THIS UNISTRUT SUPPORT SYSTEM IS DESIGNED TO SUPPORT A MAXIMUM UNIFORM LOAD OF \_\_\_ PSF. \*
2. AREA DIRECTLY ABOVE THE VERTICAL SUPPORT TO BE FREE AND CLEAR OF ALL OBSTRUCTIONS.
3. EXISTING STRUCTURE TO BE CHECKED BY OTHERS.
4. ALL CHANNEL & FITTINGS TO HAVE STANDARD UNISTRUT "PERMA-GREEN" FINISH AND ALL HARDWARE TO BE ELECTRO-GALVANIZED.

\* DESIGN LOAD VARIES BASED ON MAXIMUM SPANS - PLEASE CONTACT YOUR LOCAL UNISTRUT OFFICE FOR SPECIFIC LOADING DESIGN.

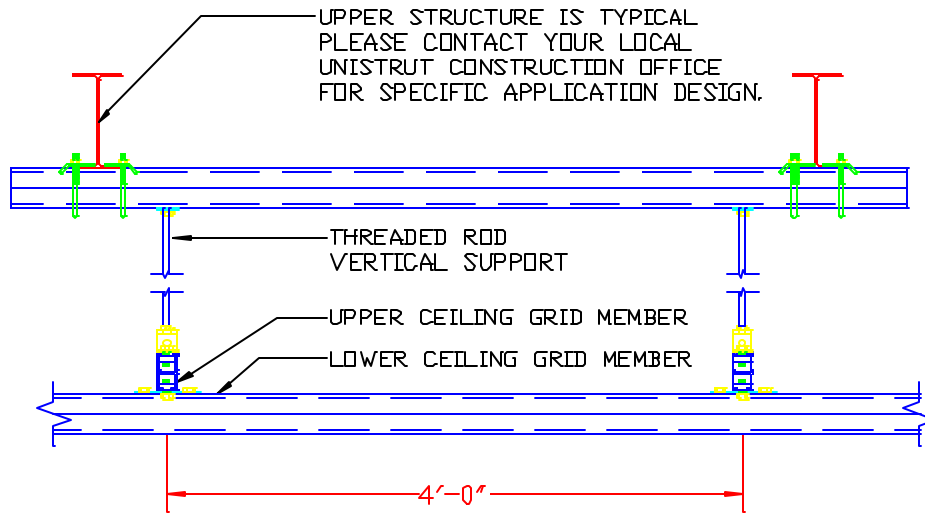

SECTION: UNISTRUT GRID SYSTEM

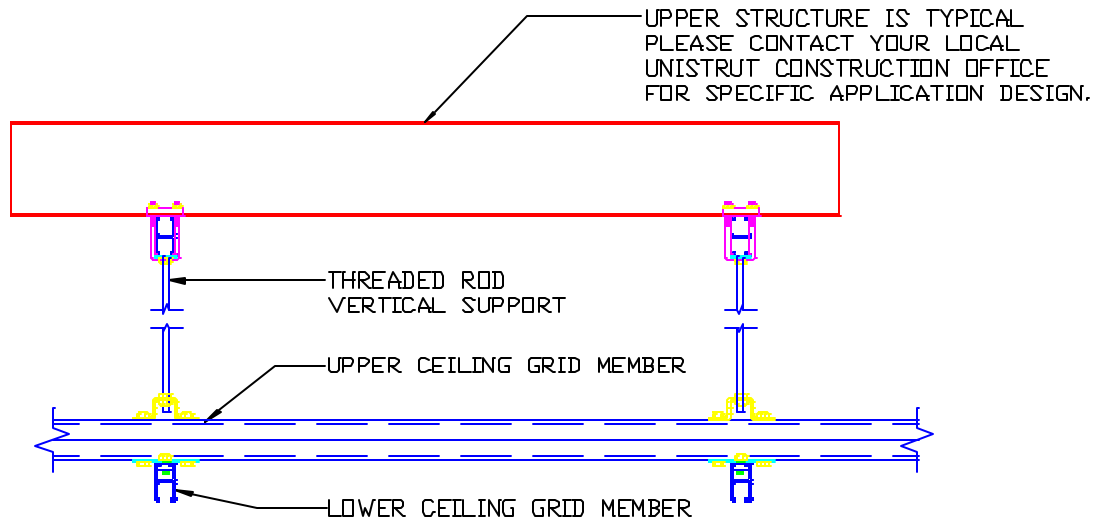

SECTION: UNISTRUT GRID SYSTEM

**UNISTRUT CORPORATION**  
 DESIGN & INSTALLATION  
 CONSTRUCTION DIVISION  
 PHONE: 1-800-468-9510

UNISTRUT 2 LEVEL 2 WAY  
 P1001 CEILING GRID

BY SB

DATE 12/08/03

TG-2L2W-01-SB

SHEET  
 1 OF 1

GENERAL NOTES

1. THIS UNISTRUT SUPPORT SYSTEM IS DESIGNED TO SUPPORT A MAXIMUM UNIFORM LOAD OF \_\_\_ PSF. \*
2. AREA DIRECTLY ABOVE THE VERTICAL SUPPORT TO BE FREE AND CLEAR OF ALL OBSTRUCTIONS.
3. EXISTING STRUCTURE TO BE CHECKED BY OTHERS.
4. ALL CHANNEL & FITTINGS TO HAVE STANDARD UNISTRUT "PERMA-GREEN" FINISH AND ALL HARDWARE TO BE ELECTRO-GALVANIZED.

\* DESIGN LOAD VARIES BASED ON MAXIMUM SPANS - PLEASE CONTACT YOUR LOCAL UNISTRUT OFFICE FOR SPECIFIC LOADING DESIGN.

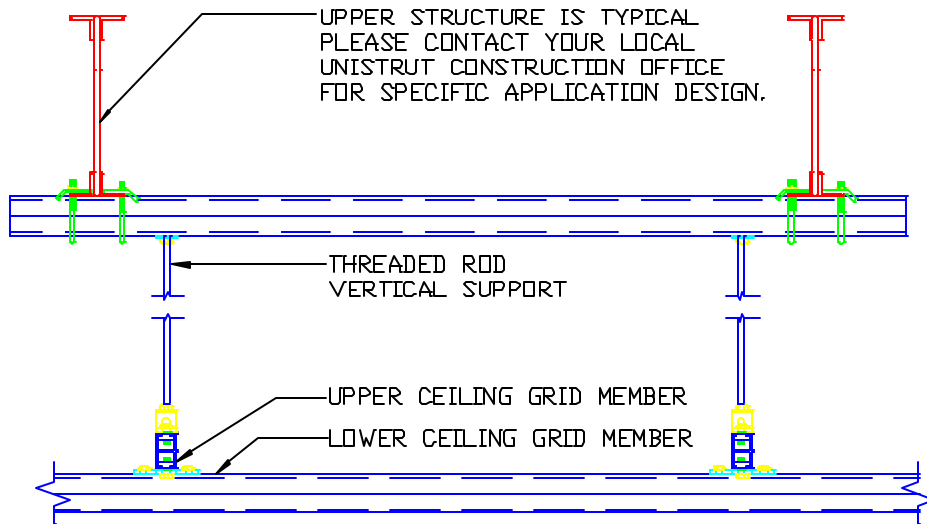

SECTION: UNISTRUT GRID SYSTEM

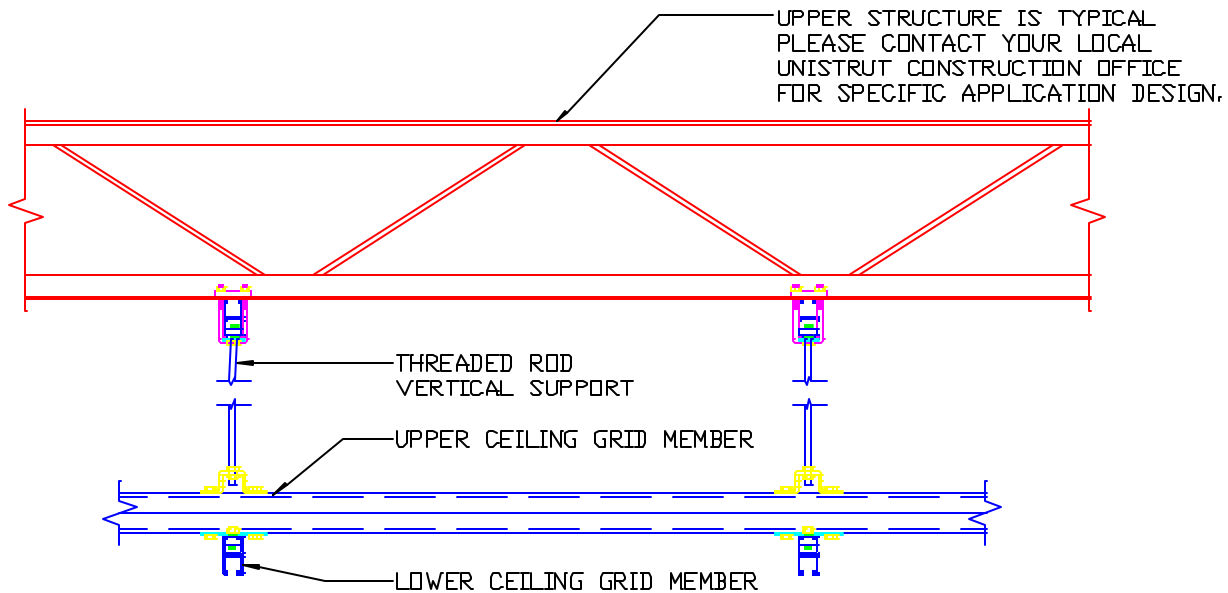

SECTION: UNISTRUT GRID SYSTEM

**UNISTRUT  
CORPORATION**

DESIGN & INSTALLATION  
CONSTRUCTION DIVISION  
PHONE: 1-800-468-9510

UNISTRUT 2 LEVEL 2 WAY  
P1001 CEILING GRID

BY SB

DATE 12/08/03

TG-2L2W-01-SJ

SHEET  
1 OF 1

**CEILING GRID System**  
Section 05160

**PART 1--GENERAL**

**1.1 SCOPE OF WORK**

1. Provide all Metal Framing material, fittings and related support system accessories as indicated on the drawings. Rails shall be true, plumb and level to the tolerances indicated when maximum loading conditions are applied due to equipment operation.
2. Provide all labor, supervision, engineering, and fabrication required for installation of the support system in accordance with the drawings and as specified herein.

**1.2 REFERENCES**

1. ASTM A 36 - Carbon Structural Steel.
2. ASTM A 570/ A 570M - Steel, Sheet and Strip, Carbon, Hot-Rolled, Structural Quality.
3. ASTM A 575 - Steel Bars, Carbon, Merchant Quality, M-Grades.
4. ASTM A 576 - Steel Bars, Carbon, Hot-Wrought, Special Quality.
5. ASTM B 117 - Operating Salt Spray (Fog) Apparatus.
6. 6. FED-STD 595 - Colors Used in Government Procurement.

**1.3 DESIGN REQUIREMENTS**

1. Support Structure: The support members shall be located as indicated on the drawings. The spacing shall be as shown on the drawings.
2. Ceiling Anchorage: Whenever possible, attachment to the ceiling structure above shall be by means of imbedded concrete inserts, through bolts, or by direct attachment to the structural framing of the building. When possible, fasteners will not be in direct pull-out.
3. Vertical Supports: Vertical supports shall provide for both basic and micro vertical adjustments.
4. Seismic Bracing: Framing system shall be adequately braced to meet all code requirements.
5. Loading: The support structure shall be designed to support a uniform load of \_\_\_\_\_ psf.
6. Safety Factor: The system shall be designed with a minimum safety factor of 3 based upon ultimate strength under static loading conditions.
7. Maximum Allowable Deflection Under Live Load: 1/240 of span; size components of single span.

**1.4 QUALITY ASSURANCE**

1. Vendor Qualifications:
  - A. The vendor shall not have had less than ten years experience in manufacturing and installing adjustable metal framing ceiling grid supports. The vendor shall demonstrate experience of projects of similar scope and size, and shall maintain continuing Quality Assurance Program for both its material and installation crews.
  - B. The manufacturer must certify in writing that components supplied have been produced in accordance with an established quality assurance program.
  - C. The vendor shall provide the single source responsibility for materials and workmanship, and shall provide a guarantee period of one year from date of acceptance by Architect/Owner.
2. Standard
  - A. Work shall meet the requirements of the following standards:
  - B. Federal, State and Local codes.
  - C. American Iron and Steel Institute (AISI) Specification for the Design of Cold-Formed Steel Structural Members August 19, 1986 Edition, December 11, 1989 Addendum
  - D. American Society for Testing and Materials (ASTM).

**1.5 SUBMITTALS**

1. Structural Calculations and Shop Drawings:
  - A. Submit structural calculations for approval by the project engineer. Calculations may include, but are not limited to:
    - a. Description of design criteria.
    - b. Stress and deflection analysis.

Section 05160

- c. Selection of framing members, fittings, and accessories.
- B. Submit all pertinent manufacturers published data.

#### 1.6 DELIVERY, STORAGE, AND HANDLING

1. All material is to be delivered to the work site in original factory packaging to avoid damage to the finish.
2. Upon delivery to the work site, all components shall be protected from the elements by a shelter or other covering.

#### 1.7 SEQUENCING AND SCHEDULING

1. Coordinate with structural concrete trades for attachments and/or embeds.
2. Install system prior to extensive electrical, mechanical or HVAC work in area, and prior to room finishes.
3. Install system prior to ceiling installation. Coordinate with the ceiling contractor.
4. The vendor shall visit the job site and familiarize himself with all existing conditions.

### PART 2--PRODUCTS

#### 2.1 ACCEPTABLE MANUFACTURER/VENDORS

1. Provide products of the following manufacturer or of an approved equal: Unistrut Corporation.
2. Installation to be done by Unistrut Construction or approved equivalent contractor.

#### 2.2 MATERIALS

1. All channel members shall be fabricated from structural grade steel conforming to the following: ASTM A 570/A 570M GR 33.
2. All fittings shall be fabricated from steel conforming to one of the following: ASTM A 575, ASTM A 576, or ASTM A 36.
3. All materials shall be stamped and identifiable by manufacturer and part number (where appropriate). Materials that appear damaged, distressed, unidentifiable or rusted shall not be used and will not be accepted.
4. Channel Sizes (see drawings for locations):
5. P1000, P1001, P5000 or P5501 Channels as manufactured by Unistrut Corp.

#### 2.3 CONNECTIONS

1. Framing fittings shall be of 1/4-inch thick steel bar, 1-5/8 inch wide, with 9/16-inch holes to accommodate 1/2-inch threaded rods.
2. The standard gripping nut (5/8-inch) used for framing and attachments shall have serrated grooves to match and engage the inturred channel edges.

#### 2.4 FINISH

1. Rust inhibiting acrylic enamel paint applied by electro-deposition, after cleaning and phosphating, and thoroughly baked. Color is per FED-STD 595A, color number 14109 (dark limit V-). Finish to withstand minimum 400 hours salt spray when tested in accordance with ASTM B 117.
2. Bolts and gripping nuts shall be electro-galvanized.
3. Concrete Inserts: Continuous channel type inserts shall be fabricated to the same general specifications as the 12 gage channel members of the framing systems and also shall have an ultimate resistance to pulling out of the concrete of not less than 7,500 pounds average for 1-3/8 inch deep inserts and 6,000 pounds average for 7/8-inch deep inserts in each foot of length. Finish of inserts shall be prior to forming and zinc coated.

### PART 3--EXECUTION

#### 3.1 EXAMINATION

1. The installer shall inspect the work area prior to installation. If work area conditions are unsatisfactory, installation shall not proceed until satisfactory corrections are completed

#### 3.2 INSTALLATION

1. Installation shall be accomplished by a fully trained installer authorized by the manufacturer, architect, general contractor or owner.

Section 05160

2. Set support system components into final position true to line, level and plumb, in accordance to approved shop drawings.
3. Anchor material firmly in place. Tighten all connections to their recommended torques.
4. The mounting surfaces of the support system shall be horizontal within the tolerance of 1/32 inch and within 1/16 inch in any 24 inch length of the rails.
5. The elevation of one rail mounting surface to the other shall be within 1/8-inch in any 24-inch length of the rails.

### 3.3 CLEANUP

1. Upon completion of the work of this section, remove all protective wraps and debris. Repair any damage due to installation.

### 3.4 PROTECTION

1. During installation, it shall be the responsibility of the installer to protect this work from damage.
2. Upon completion of this scope of work, it shall be the responsibility of the general contractor to protect this work from damage during the remainder of construction on the project and until substantial completion.